

# Theory of Operation

After the TriBus transfer and input data voting have corrected the input values, these corrected values are used by the main processors as input to the user-written control program. (The control program is developed in the TriStation software and downloaded to the main processors.) The 32-bit main microprocessor executes the user-written control program in parallel with the neighboring main processor modules.

The user-written control program generates a table of output values based on the table of input values, according to the rules built into the control program by the customer. The I/O processor on each main processor manages the transmission of output data to the output modules by means of the I/O bus.

Using the table of output values, the I/O processor generates smaller tables, each corresponding to an individual output module in the system. Each small table is transmitted to the appropriate

channel of the corresponding output module over the I/O bus. For example, Main Processor A transmits the appropriate table to Channel A of each output module over I/O Bus A. The transmittal of output data has priority over the routine scanning of all I/O modules.

The I/O and COMM processor manages the data exchanged between the main processors and the communication modules using the communication bus, which supports a broadcast mechanism.

The model 3008 Main Processors provide 16 megabytes of DRAM, which is used for the control program, sequence-of-events data, I/O data, diagnostics and communication buffers.

In the event of an external power failure, the integrity of the user-written program and the retentive variables is protected for a minimum of six months.

The main processor modules receive power from dual power modules and power rails in the main chassis. A failure on one power module or power rail will not affect the performance of the system.

## Bus Systems and Power Distribution

Three triplicated bus systems are etched on the chassis backplane: the TriBus, the I/O bus and the communication bus.

The TriBus consists of three independent serial links which operate at 25 megabits per second. The TriBus synchronizes the main processors at the beginning of a scan. Then each main processor sends its data to its upstream and downstream neighbors. The TriBus performs one of two functions with the data:

- Transfer of data only—for I/O, diagnostic and communication data.
- Comparing data and flagging disagreements—for the previous scan's output data and memory of user-written control program.

An important feature of the Tricon's fault-tolerant architecture is the use of a single transmitter to send data to both the upstream and downstream main processors. This ensures receipt of the same data by the upstream processor and downstream processor.

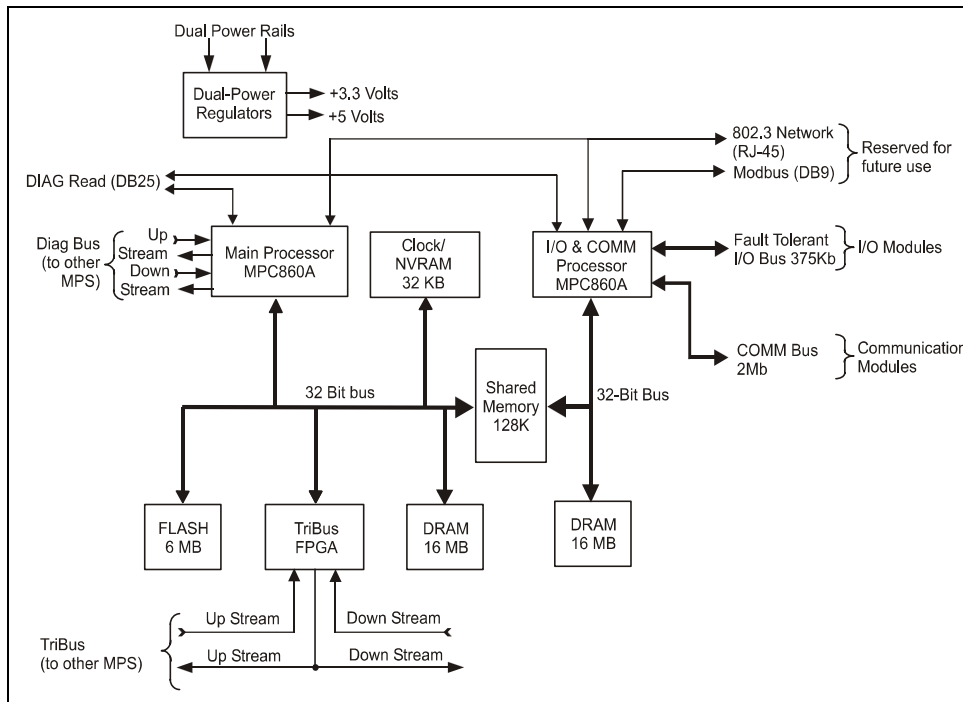

Main Processor (Model 3008) Architecture

## System Configuration Guidelines

A Tricon system must have a main chassis and may have up to 14 expansion or remote expansion (RXM) chassis. The following configuration guidelines apply.

### Main Chassis Configuration Guidelines

- There is one main chassis with a chassis address of 1.
- The main chassis must contain three model 3008 Main Processors for Tricon v9.6 and later systems.
- The main chassis must house two power modules.
- The main chassis provides six logical slots for user-selected modules and one COM slot.
- A v9 low-density configuration includes a v5–v8 chassis with v9 main processors, communication, and I/O modules.

### Expansion Chassis Configuration Guidelines

- Expansion chassis are used when the total I/O bus cable length for the system is less than 100 feet (30 meters) for each channel.
- Each expansion chassis must have a unique address between 2 and 15. This address must not be used by any other chassis.
- Each expansion chassis must house two power modules.
- One set of triplicated I/O bus cables is used to interconnect channels A, B and C between expansion chassis.
- Each expansion chassis provides eight logical slots.

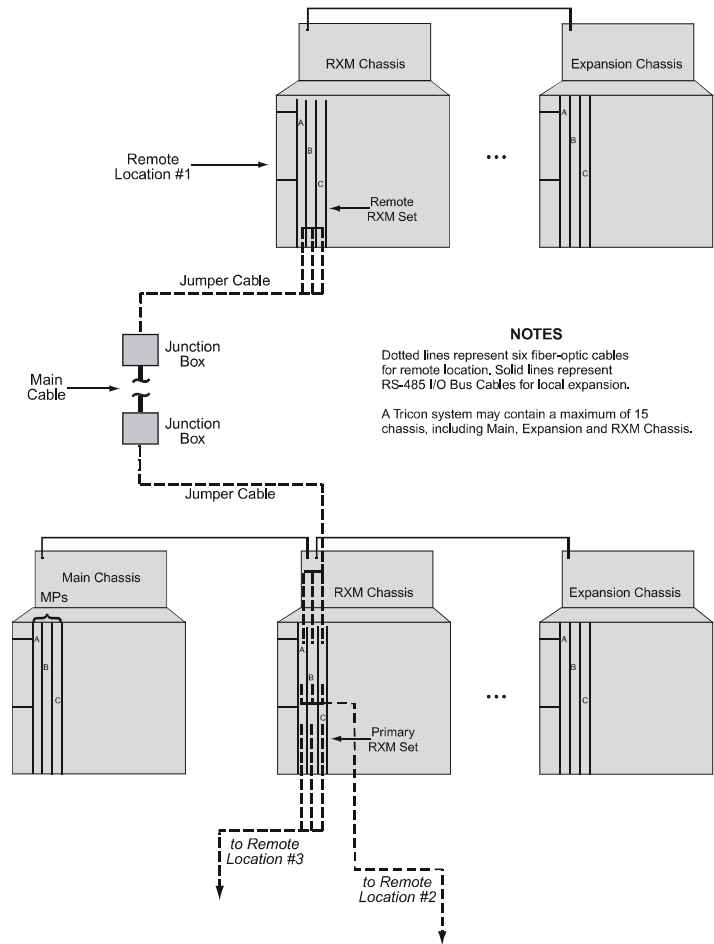

**System Configuration with Three Remote Locations**

### RXM Chassis Configuration Guidelines

- RXM chassis must be used when the total I/O bus cable length for the system is greater than 100 feet (30 meters) for each channel.
- Each RXM chassis must have a unique address between 2 and 15. This address must not be used by any other chassis.
- One RXM chassis must be located within 100 feet (30 meters) of the main chassis. This RXM chassis must house the primary RXM module set. Up to 3 primary RXM module sets are normally supported.

Contact Triconex regarding other configurations.

- Each primary RXM module set can support up to 3 remote sites, each up to 7.5 miles (12 kilometers) away.
- One RXM chassis must be located at each remote site. This RXM chassis must house a remote RXM module set.
- A primary RXM module set and a remote RXM module set are connected by 6 fiber-optic cables which transmit and receive signals for channels A, B and C.

# System Configuration

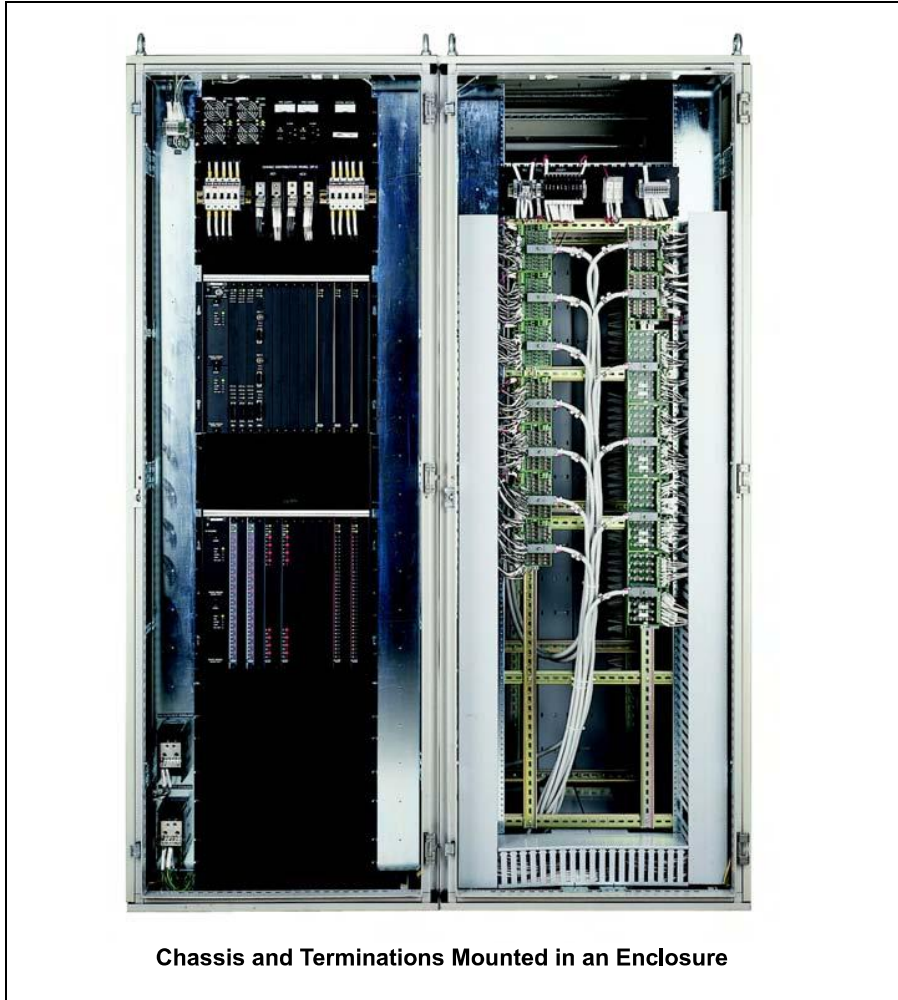

**Chassis and Terminations Mounted in an Enclosure**

- RXM chassis can be connected to local expansion chassis using I/O bus cables.
- Each RXM chassis must contain 2 power modules.
- Each RXM chassis provides 6 logical slots for I/O modules and 1 blank (unused) slot.

## **Communication Module Configuration Guidelines**

The following rules apply to the TCM, EICM, NCM, HIM, SMM, and ACM in a Tricon system:

- A TriStation PC communicates with a Tricon controller through a TCM, EICM, NCM or ACM, so at least one of these modules must be installed in the main chassis or Chassis 2.
- One logical slot is available for EICMs or ACMs, respectively. Matched pairs of these modules can be installed in both the left and right positions of one logical slot.
- Up to two logical slots can be configured for NCMs. Matched pairs of NCMs can be installed in the left and right positions of each logical slot. If only one logical slot is used, the slot can be in the main chassis or Chassis 2. If two logical slots are used, they must be Slot 6 and 7 in the main chassis, and peer-to-peer cannot be used.
- Up to two logical slots can be configured for TCMs. Matched pairs of TCMs can be installed in the left and right positions of each logical slot, and they can be located in the main chassis or Chassis 2.

- Up to three logical slots can be configured for SMMs. A matched pair of SMMs can be installed in the left and right positions of each logical slot. All three slots must be in the main chassis or Chassis 2.
- Up to two logical slots can be configured for HIMs. Both slots must be in the main chassis.
- The COM slot can be configured only for the EICM, TCM or NCM.
- You cannot install an NCM and a TCM in the same Tricon system. You also cannot install an EICM and a TCM in the same system.
- If communication modules are housed in Chassis 2, this chassis must be connected directly to the main chassis using I/O COMM cables (model 9001) rather than standard I/O bus cables.
- Chassis 2 can be an I/O expansion chassis or a primary RXM chassis.

### Chassis Power Limitations

To maintain the safety and reliability of the Tricon, each system must be configured for operation under a worst-case scenario. These circumstances include operation with only one functional power supply at 140°F (60°C), ambient. (See [“Power Modules” on page 24](#) for detailed specifications). Under these conditions, the power supply is rated to deliver 175 watts. The table to the right lists the logic power consumption per module in watts.

Module Type	Watts Consumed
ACM	15
Analog Input	10
Analog Input, Isolated	15
Analog Input, High Density	10
Analog Output	15
Digital Input, High Density	10
Digital Input, Single	10
Digital Input, TMR	10
Digital Output, AC	10
Digital Output, DC	10
Digital Output, Dual	10
Digital Output, Supervised	15
EICM	10
HIM 10	
Main Processor, model 3008	10
NCM	20
Power Module	n/a
SMM	20
TCM	7
Thermocouple Input, Isolated	15
Thermocouple Input, Non-Isolated	10
Pulse Input	20
Pulse Totalizer	10
RXM	5
Relay Output	15

# Product Specifications

## Standard Tricon Products

Description	Model No.	See
<b>Chassis Assemblies</b>		
Main Chassis, High Density Configuration, includes the Tricon printed manuals	8110	page 13, page 21
Expansion Chassis, High Density Configuration	8111	page 13, page 21
Remote Expansion Chassis, High Density Configuration	8112	page 13, page 21
I/O Bus Expansion Cables (Set of 3)	9000 <sup>1</sup>	page 12
I/O-COMM Bus Expansion Cables (Set of 3)	9001	page 12, page 21
Blank I/O Slot Panel	8105	page 22
<b>Power Modules</b>		
120 VAC/VDC – 175-Watt Power Module	8310	page 24
24 VDC – 175-Watt Power Module	8311	page 24
230 VAC – 175-Watt Power Module	8312	page 24
<b>Main Processor Modules</b>		
3008 Main Processor, 16 megabytes DRAM	3008	page 25
<b>Communication Hardware and Software</b>		
Tricon Communication Module (TCM), Ethernet (802.3) and serial (RS-232/RS-485) ports	4351A, 4352A, 4353, 4354	page 26
Enhanced Intelligent Communication Module (EICM), serial (RS-232/RS-422/RS-485) ports	4119, 4119A	page 27
Safety Manager Module (SMM), Honeywell UCN Interface	4409	page 28
Network Communication Module (NCM), Ethernet (802.3) ports	4329, 4329G	page 29
Advanced Communication Module (ACM), Foxboro I/A Series Nodebus Interface	4609	page 30
Hiway Interface Module (HIM), Honeywell Data Hiway Interface	4509	page 31
Triconex DDE Server Software	7523-1	page 61
Network Accessory Kit (Ethernet thin cable, connectors and terminators)	7600-3	n/a
<b>Remote Extender Modules</b>		
Primary RXM, Multi-Mode Fiber Optics, Set of 3 Modules	4200-3	page 32
Remote RXM, Multi-Mode Fiber Optics, Set of 3 Modules	4201-3	page 32
Primary SRXM, Single-Mode Fiber Optics, Set of 3 Modules	4210-3	page 32
Remote SRXM, Single-Mode Fiber Optics, Set of 3 Modules	4211-3	page 32
<b>TriStation Software</b>		
TriStation 1131 v4.1.x Software License with printed manuals	Contact Triconex for current model number	page 63
TriStation 1131 v3.1.3 Software License with printed manuals	7244-4	page 63
CEMPLE Language Editor, v3.1.3	7224-4	page 67
<b>Documentation Sets</b>		
Tricon Planning and Installation, Field Terminations, and Communication printed manuals	Contact Triconex for current model number	
Triconex User Documentation, includes all manuals in PDF format (CD-ROM)	Contact Triconex for current model number	

1. I/O Bus Expansion Cables are available in custom lengths. Please contact Triconex for more information.

## Main Processor Modules

Model 3008 Main Processors are available for Tricon v9.6 and later systems. For detailed specifications, see the *Planning and Installation Guide for Tricon Systems*.

Three MPs must be installed in the main chassis of every Tricon system. Each MP independently communicates with its I/O subsystem and executes the user-written control program.

### Sequence of Events (SOE) and Time Synchronization

During each scan, the MPs inspect designated discrete variables for state changes known as *events*. When an event occurs, the MPs save the current variable state and time stamp in the buffer of an SOE block.

If multiple Tricon systems are connected by means of NCMs, the time synchronization capability ensures a consistent time base for effective SOE time-stamping. See [page 70](#) for more information.

### Diagnostics

Extensive diagnostics validate the health of each MP, I/O module and communication channel. Transient faults are recorded and masked by the hardware majority-voting circuit. Persistent faults are diagnosed and the errant module is hot-replaced.

MP diagnostics perform these tasks:

- Verify fixed-program memory and static RAM

- Test all basic processor and floating-point instructions and operating modes
- Validate user memory by means of the TriBus hardware-voting circuitry
- Verify the shared memory interface with each I/O communication processor and channel
- Verify handshake and interrupt signals between the CPU, each I/O communication processor and channel
- Check each I/O communication processor and channel microprocessor, ROM, shared memory access and loopback of RS-485 transceivers
- Verify the TriClock and TriBus interfaces

## Physical Description of Model 3008 Main Processors

Feature	Description
Microprocessor	Motorola MPC860, 32 bit, 50 MHz
Memory	<ul style="list-style-type: none"> <li>• 16 MB DRAM (non-battery backed-up)</li> <li>• 32 KB SRAM, battery backed-up</li> <li>• 6 MB Flash PROM</li> </ul>
Tribus Communication Rate	<ul style="list-style-type: none"> <li>• 25 megabits per second</li> <li>• 32-bit CRC protected</li> <li>• 32-bit DMA, fully isolated</li> </ul>
I/O Bus and Communication Bus Processors	<ul style="list-style-type: none"> <li>• Motorola MPC860</li> <li>32 bit</li> <li>50 MHz</li> </ul>

## Indicators on Main Processors

PASS	Module has passed self-diagnostic tests
FAULT	Module has a fault and should be replaced
ACTIVE	Module is executing the user-written control program
MAINT1	Maintenance indicator 1
MAINT2	Maintenance indicator 2
COM TX	Transmitting data across COMM bus
COM RX	Receiving data from COMM bus
I/O TX	Transmitting data across I/O bus
I/O RX	Receiving data from I/O bus

