

PART NUMBER 104003-01  
REVISION E,

# ***3300 SYSTEM COMPATIBILITY GUIDE***

**BENTLY**<sup>®</sup>  
**NEVADA**

---

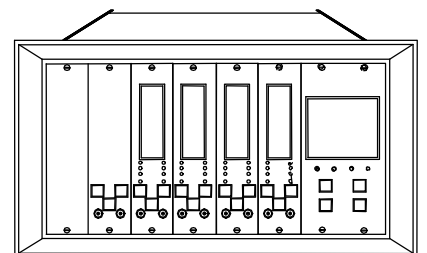

## NOTICE

### READ THE FOLLOWING BEFORE INSTALLING OR OPERATING EQUIPMENT

Bently Nevada Corporation has attempted to identify areas of risk created by improper installation and/or operation of this product. These areas of information are noted as **WARNING** or **CAUTION** for your protection and for the safe and effective operation of this equipment. Read all instructions before installing or operating this product. Pay particular attention to those areas designated by the following symbols.

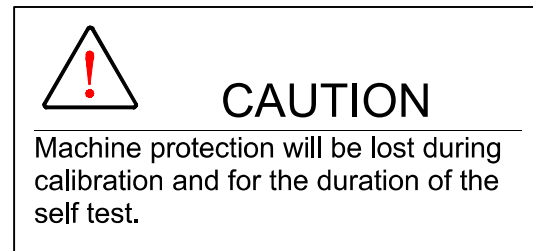
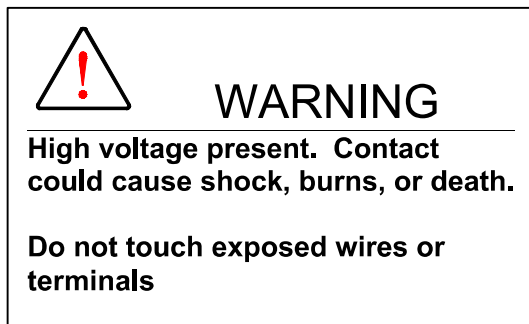

Copyright © 2000 Bently Nevada Corporation. All rights reserved.

The information contained in this document is subject to change without notice.

The following are trademarks of Bently Nevada Corporation in the United States and Other Countries:

Actionable Information<sup>SM</sup>, Actionable Information to the Right People at the Right Time<sup>SM</sup>, ADRE®, Bently ALIGN™, Bently BALANCE™, Bently DOCUVIEW™, Bently LUBE™, Bently Nevada®, Bently PERFORMANCE™, CableLoc™, ClickLoc™, Data Manager®, Decision Support<sup>SM</sup>, DemoNet™, Dynamic Data Manager®, Dynamic Transmitter™, Engineer Assist™, FieldMonitor™, FluidLoc®, flexiTAM™, flexiTAM™, Helping You Protect and Manage All Your Machinery®, HydroVU™, Key Ø®, Keyphasor®, Machine Condition Manager™ 2000, MachineLibrary™, Machine Manager™, MicroPROX®, Move Data, Not People®, Move Information, Not Data™, NSV™, Preformalign™, PROXPAC®, Proximitor®, REBAM®, SE™, Seismoprobe®, ServoFluid™, Smart Monitor®, Snapshot™, System 1™, System Extender™, TDXnet™, TDIXconnX™, Tecknowledgy™, TipLoc™, TorXimitor®, Transient Data Manager®, Trendmaster®, TrimLoc™, VAM™, Velomitor®, XLerometer™

The *Bently Nevada Corporation Orbit Design*, *Bently Balance and Design*, *System 1 Enabled and Design*, and *M-Squared and Design* are all trademarks or registered marks of Bently Nevada Corporation in the United States and other countries.

No part of this publication may be reproduced, transmitted, stored in a retrieval system nor translated into any human or computer language, in any form or by any means, electronic, mechanical, magnetic, optical, chemical, manual, or otherwise, without the prior written permission of the copyright owner,

**Bently Nevada Corporation**  
**1631 Bently Parkway South**  
**Minden, Nevada 89423 USA**  
**Telephone (800) 227-5514 or (775) 782-3611**  
**Fax (775) 782-9259**

Copyright infringement is a serious matter under the United States of America and international copyright laws.

## FOREWORD

This document is intended for personnel who maintain the 3300 Monitoring System. The procedures are presented in step-by-step graphic format.

### RELATED DOCUMENTS

- 3300 System Overview, 80171
- 3300 System Installation Instructions, 80172
- 3300 System Troubleshooting, 80173
- 3300/12 AC Power Supply, 89602
- 3300/14 DC Power Supply, 101256
- 3300/03 System Monitor, 89604
- 3300 Internal Barrier Manual, 88837

### SYMBOLS

Special symbols are used in the manual to illustrate specifics in the step-by-step processes. For example:



Press

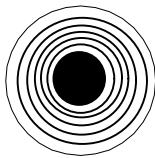

Flashing

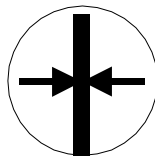

Connect

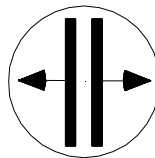

Disconnect

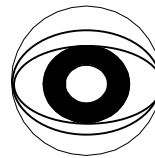

Observe

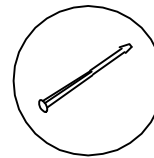

Screwdriver

# CONTENTS

1	PURPOSE.....	1
2	SYSTEM IDENTIFICATION .....	3
	2.1 Configuration Definitions.....	3
	2.1.1 Original System .....	3
	2.1.2 Mixed System .....	3
	2.1.3 SDI/DDI System.....	3
	2.2 System Identification.....	4
	2.2.1 Original System .....	5
	2.2.2 Mixed System .....	6
	2.2.3 SDI/DDI System.....	7
	2.3 Rack Identification .....	8
	2.3.1 Original Backplane.....	9
	2.3.2 SDI/DDI Backplane.....	10
	2.4 Monitor Firmware Identification .....	11
3	SYSTEM COMPATIBILITY .....	14
	3.1 Mixed System Compatibility Issues.....	14
	3.2 Additional Compatibility Issues .....	14
	3.2.1 Monitors.....	14
	3.2.2 Communications Processors .....	14
	3.3 Communication Processor and Software Compatibility .....	15
4	APPENDIX A.....	16
	4.1 Hardware Upgrade Kit Part Numbers.....	16
5	APPENDIX B.....	16
	5.1 Firmware Upgrade Kit Part Numbers .....	16

# 1 PURPOSE

Since the original design of the 3300 monitoring system, the Serial Data Interface/Dynamic Data Interface (SDI/DDI) communication protocols have been added. As a result, there are now three different 3300 configurations in the field: Original, Mixed, and SDI/DDI configurations. The purpose of this Compatibility Guide is to assist field personnel with the identification of each configuration and to explain the differences between these configurations. This document is not intended to be an upgrade guide to change from one configuration to another.

The 3300 system has been enhanced to upgrade the computer/communications interface options. The 3300 SDI/DDI communication protocols were released in April 1992 with the external communication processors, SDIX/DDIX, TDIX and TDXnet™ released in August 1992, July 1993 and December 1997, respectively. 3300 components that have been changed to implement these interface options are the System Monitor, AC and DC Power Supply, Rack Backplane, and individual monitor firmware. 3300 systems that consist of **all** the upgraded components are referred to as an SDI/DDI system.

The information in this guide is divided into these two sections:

Section 2, System Identification, lists the three configurations of the 3300 Monitoring System which are authorized by Bently Nevada Corporation and shows how to identify each one. Identifying your system will help you make decisions about replacement parts and computer/communications interfaces.

Section 3, System Compatibility, describes the compatibility between 3300 systems, communication interfaces, and monitoring and diagnostic software.

**Table 1** on the following page shows some definitions and explanations for the part numbers and abbreviations used in this guide.

# 1 PURPOSE

**Table 1**  
**3300 System Part Numbers and Definitions**

<b>Part Number/ Abbreviation</b>	<b>Description</b>	<b>Function</b>
3300/01-01	Original Version of Basic System Monitor.	Basic service to the rack including setpoint adjust, reset, OK relay, and system Keyphasor signals.
3300/01-02	Serial Interface System Monitor.	All of the functions of the 3300/01-01 plus serial communications interface using Allen-Bradley or Modicon Modbus® communication protocol.
3300/03-01	Enhanced Version of the Basic System Monitor.	All of the functions of the 3300/01-01 system monitor. Can be upgraded to a Serial Data Interface or Dynamic Data Interface System Monitor through an authorized service center. Contact your local Bently Nevada Sales and Service office for more details.
3300/03-02	Serial Data Interface (SDI) System Monitor.	All of the functions of the 3300/01-02 plus enhanced serial communications capability.
3300/03-03	Dynamic Data Interface (DDI) System Monitor.	All of the 3300/03-02 functions plus the functions of a Dynamic Data Manager® Communications Processor with added features.
PIM	Power Input Module	Located behind the Power Supply and System Monitor on a 3300 rack. This module contains the Input/Output connections for computer/communication interfaces, system functions and rack power.
DDM CP	Dynamic Data Manager® Communications Processor.	Acquires steady state dynamic and static data from a monitor rack and provides temporary data storage and communications to a Bently Nevada host computer.
TDM CP	Transient Data Manager® Communications Processor.	Provides all of the functions of a DDM CP plus acquires transient (start-up/coast-down) dynamic and static data from a monitor rack and provides temporary data storage and communications to a Bently Nevada host computer.
PDM CP	Process Data Manager Communications Processor.	Acquires process variable data, provides temporary storage and communicates to a Bently Nevada host computer.
SDIX/DDIX CP	External Serial Data Interface/Dynamic Data Interface Communications Processor.	An externally housed communications module designed for use with a 3300/03-01 System Monitor in an original 3300 system. Provides the same communications interface functions as a 3300/03-02 or 3300/03-03 System Monitor.
TDIX CP	Transient Data Interface/Serial Data Interface Communications Processor.	External communications module that provides all of the functions of the TDM and SDI/DDI, plus additional features.
TDXnet CP	External Transient Data Interface/Serial Data Interface Communications Processor.	External communications module that provides all of the functions of the TDIX plus ethernet communication capabilities.
System 64 Software	A computer-based online monitoring and diagnostic system.	Communicates with up to 64 monitor racks using DDM CP interfaces to the racks.
DDM/TDM Software	Monitoring and diagnostic software package.	Applications software for online monitoring and diagnostics. Interfaces to monitor systems through either a DDM or TDM CP and to process variable measurements through a PDM CP.
DDM2/TDM2 Software	Monitoring and diagnostic software package.	Second generation of the DDM/TDM software. Interfaces to DDI, DDIX and TDIX in addition to all the communication processors which the original DDM/TDM software worked with.
DM2000 Software	Computer on-line monitoring software package.	Software package that operates on Bently Nevada host. Interfaces to a SDI(X)/DDI(X), TDIX, or TDXnet CP.

## 2 SYSTEM IDENTIFICATION

- This section should be used to help define and identify each of the three configurations of the 3300 Monitoring System Bently Nevada supports. The configurations are defined by the rack (backplane version), Power Supply, System Monitor, and firmware installed in individual monitors. The three possible 3300 configurations are explained below.
- Use **Table 2** on the next page to clarify exactly which 3300 configuration you may have.

### 2.1 Configuration Definitions

#### 2.1.1 Original System

- This is the first generation 3300 System. This system **may** have serial communication capability, but it predates and is **not** compatible with the internal data interfaces (SDI/DDI) and most recent external communication processors (SDIX/DDIX, TDIX and TDXnet). The Original System can, however, communicate with a Digital Control System (DCS) or with DM2000 Software through a DDM, PDM, or TDM CP.
- These systems can be upgraded to the Mixed System or SDI/DDI System configuration, depending on your interface requirements.

#### 2.1.2 Mixed System

- This is the Original System with a 3300/03-01 System Monitor that does **not** have internal SDI/DDI capabilities but can interface to a DDM, TDM, PDM, or SDIX/DDIX CP. In order to interface to a TDIX or TDXnet CP, the firmware in each monitor **must** be SDI/DDI compatible.

**NOTE:** The System Monitor must be configured correctly with jumpers depending upon the external Communication Processor that is being used. The DDM, TDM, and PDM use a different static interface than the SDIX/DDIX, TDIX, and TDXnet. Refer to the System Monitor Manual (BNC Document 89604, table 1) for specific jumper configurations.

- **Table 3** in Section 2.4 lists the SDI/DDI compatible monitor firmware part numbers.
- The Mixed System can be upgraded to an SDI/DDI System, by changing the backplane, power supply, and the firmware in each of the monitors.

#### 2.1.3 SDI/DDI System

- This is the newest generation of the 3300 System. The System Monitor, Power Supply, and Backplane are all SDI/DDI-compatible, with the System Monitor configured with or without internal SDI/DDI communications.

**NOTE:** The System Monitor must be configured correctly with jumpers depending upon the external Communication Processor that is being used. The DDM, TDM, and PDM use a different static interface than the SDIX/DDIX, TDIX, and TDXnet. Refer to the System Monitor Manual (BNC Document 89604, table 1) for specific jumper configurations.

- The SDI/DDI System is compatible with the following Bently Nevada Communications Processors and monitoring software packages: DDM CP, TDM CP, SDIX/DDIX CP, TDIX CP, TDXnet CP, DDM/TDM Software, DDM2/TDM2 Software, System 64 Software, and DM2000 Software.

## 2 SYSTEM IDENTIFICATION

**Table 2**  
**Possible 3300 System Configurations**

Configuration	System Monitor	Rack (Backplane) <sup>2</sup>	Power Supply <sup>2</sup>	Monitor Firmware <sup>1</sup>
<b>Original (old) System</b>	3300/01-01 or 3300/01-02	3300/05 Option AA = 01 thru 17	3300/10 or /11 or /14 <sup>3</sup>	Original firmware or SDI/DDI firmware
<b>Mixed System</b>	3300/03-01	3300/05 Option AA = 01 thru 17	3300/10 or /11 or /14 <sup>3</sup>	Original firmware or SDI/DDI firmware
<b>SDI/DDI system</b>	3300/03-01, or 3300/03-02, or 3300/03-03	3300/05 Option AA = 21 thru 37	3300/12 or /14	SDI/DDI firmware

### NOTES:

1. See **Table 3** in Section 2.4 for a list of SDI/DDI compatible firmware for each monitor. Some monitors were originally shipped with SDI/DDI compatible firmware.
2. It is not possible to use the old backplane with the new power supplies or to use the new backplane with the old power supplies.
3. If the 3300/14 DC Power Supply is to be used with the Original backplane, the original PIM MUST be used.

## 2.2 System Identification

The following sections discuss how to determine the configuration of your 3300 System. You may use the following steps as a guideline to identify your monitoring system.

- Examine the front panels of the System Monitor and Power Supply and check the Power Input Module on the back of the rack. Use the information in Sections 2.2.1, 2.2.2 and 2.2.3 to determine your system configuration.
- If there is any question as to the system configuration after completing step 1, use Section 2.3 to identify the backplane. The backplane determines whether the rack is an SDI/DDI System rack or an Original System rack.

**Note:** The new backplane cannot be used with the old power supplies and the old backplane cannot be used with the new power supplies. They BOTH must be updated at the same time.

- Use Section 2.4 to determine the firmware identity on individual 3300 monitors. The firmware in some early 3300 monitors is not compatible with newer generation data interfaces (SDIX/DDIX, TDIX, or TDXnet). Similarly, some new multi-channel monitors are not compatible with older external Communications Processors. See Section 3 for compatibility information.

## 2 SYSTEM IDENTIFICATION

### 2.2.1 Original System

- Consists of the 3300/01-XX System Monitor, 3300/10 or /11 Power Supply and one of the Power Input Modules shown in **Figure 1**.
- If necessary, see Section 2.3.1 to identify an original backplane.
- See Appendix A for hardware upgrade kit part numbers and/or contact your Bently Nevada representative to upgrade a system.
- See **Table 4** in Section 3.3 for information on compatibility with communication processors and software for this system configuration.

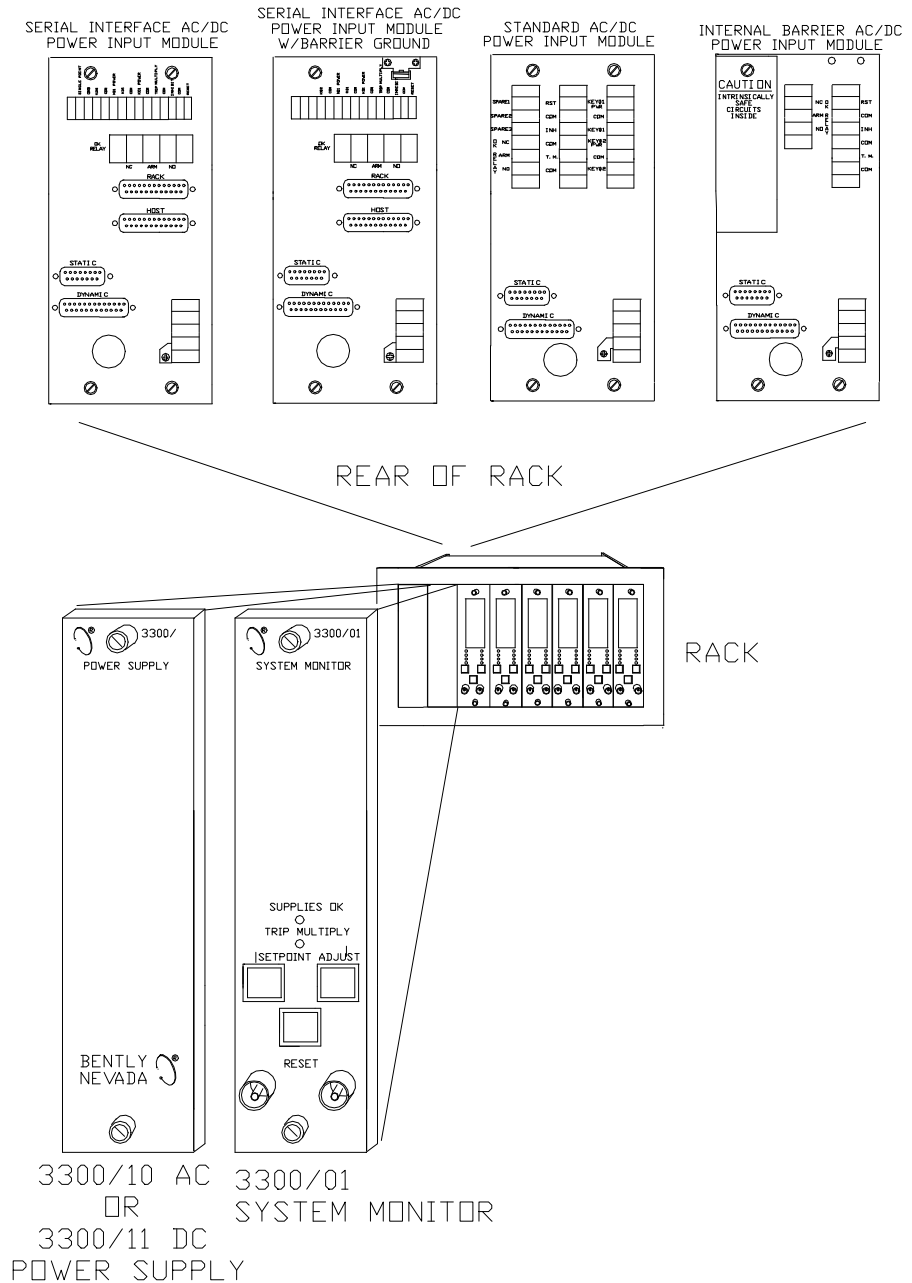
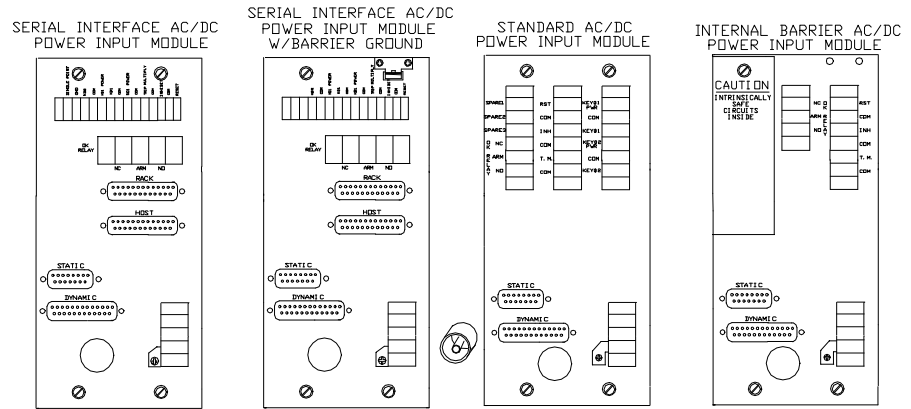

**Figure 1**  
Original System

## 2 SYSTEM IDENTIFICATION

### 2.2.2 Mixed System

- Consists of an original system with a 3300/03-01 System Monitor, a 3300/10 or /11 or /14 Power Supply, an original backplane, and one of the original Power Input Modules shown in **Figure 2**.



- In this configuration the 3300/03-01 is a replacement for the 3300/01-01 System Monitor. Note that only two Keyphasor transducers, KEYΦ1 and KEYΦ2 are available.

- See **Appendix A** for the list of hardware upgrade kit part numbers and/or contact your Bently Nevada representative to upgrade a system.

- See **Table 4** in Section 3.3 for information on compatibility with communications processors and software for this system configuration.

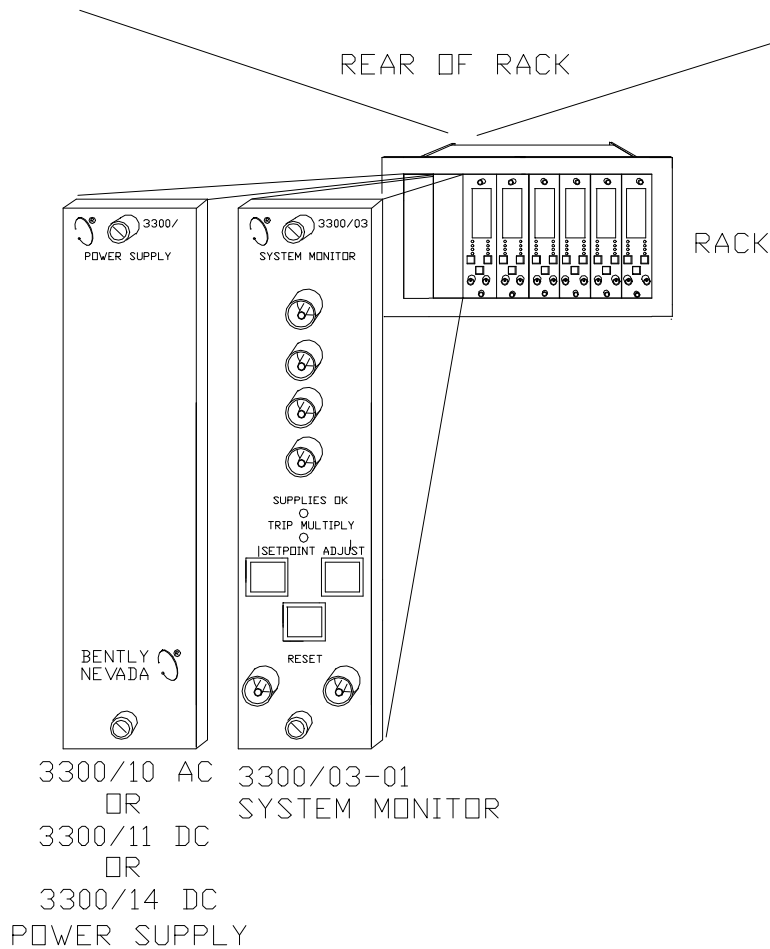
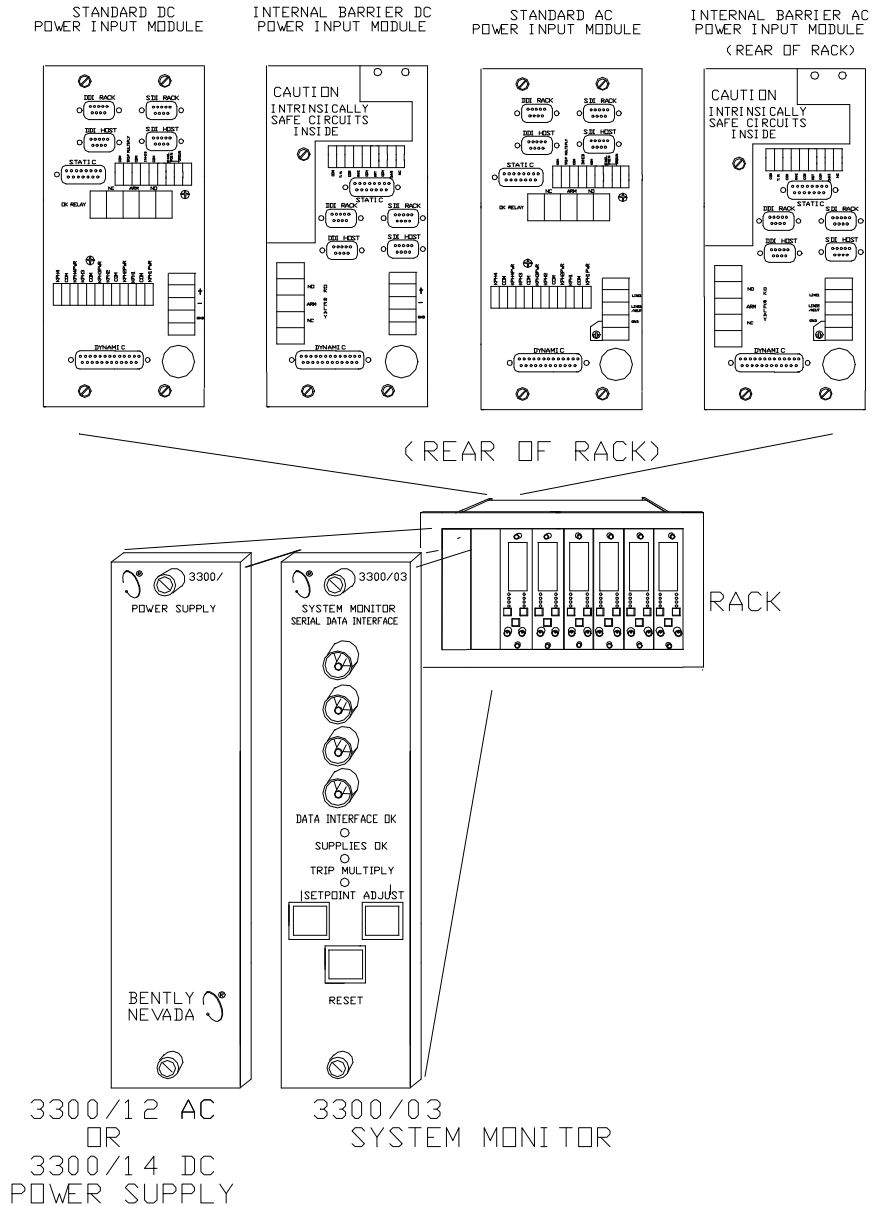

**Figure 2**  
Mixed System

## 2 SYSTEM IDENTIFICATION

### 2.2.3 SDI/DDI System

- Consists of a 3300/03-01, -02, or -03 System Monitor, a 3300/12 or /14 Power Supply, a new backplane and one of the PIMs shown in **Figure 3**.
- See **Table 4** in Section 3.3 for information on compatibility with communication processors and software for this system configuration.



**Figure 3**  
SDI/DDI System

## 2 SYSTEM IDENTIFICATION

### 2.3 Rack Identification

Use this section if you have not been able to determine the configuration using **Figures 1 through 3** in Section 2.2.

Use the following steps in this section to further assist in the identification:



### CAUTION

Machine protection will be lost during this procedure.

1. Disconnect power from the rack.
2. Remove the Power Supply and System Monitor and Power Input Module.

Location of backplane shown with dashed lines.

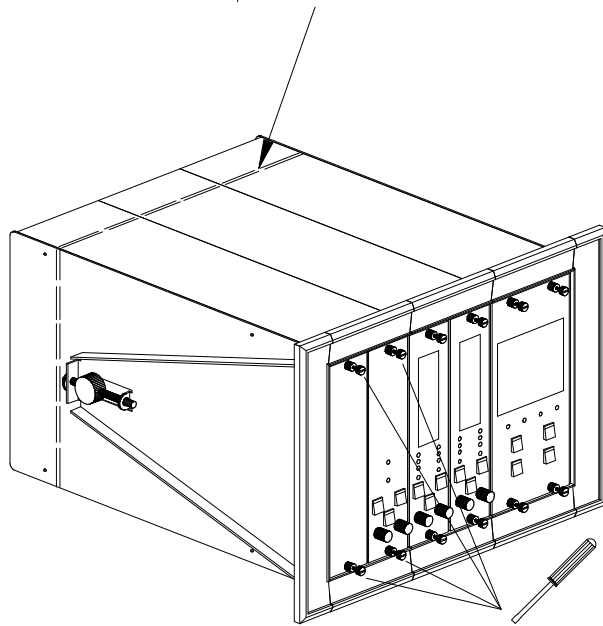

**Figure 4**  
Full Rack

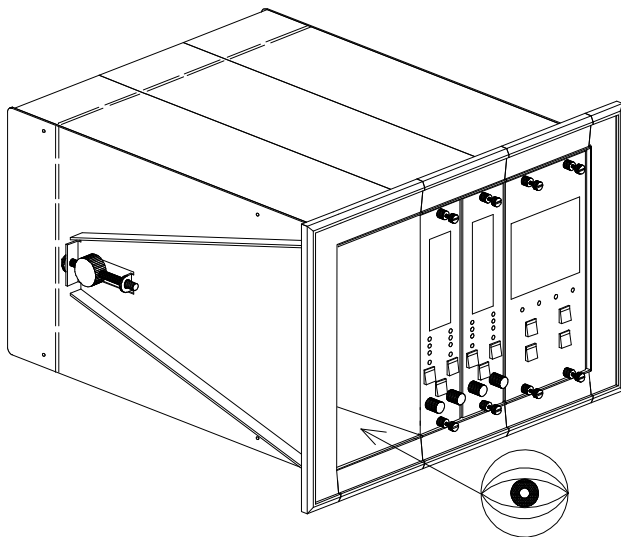

**Figure 5**  
Rack without Power Supply and System Monitor

3. Observe the location and position of the connectors on the backplane behind the Power Supply and System Monitor rack slots. Use the front view of the backplane shown in **Figures 6, 7 and 8** to identify your backplane.

## 2 SYSTEM IDENTIFICATION

### 2.3.1 Original Backplane

Two versions of the backplane may be installed in an original system. Identifying features are shown in Figures 6 and 7, below.

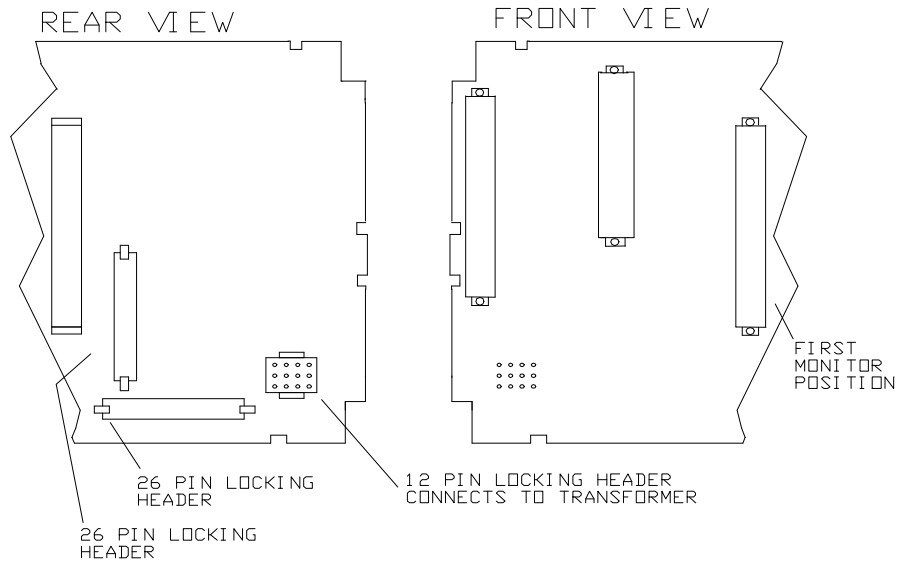

Figure 6  
Original Backplane

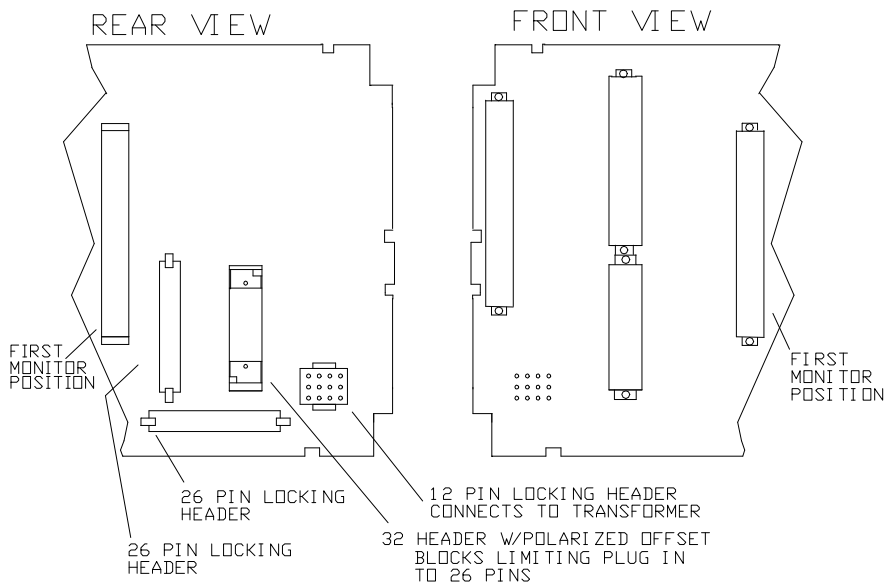

Figure 7  
Original Backplane, w/Serial Interface

## 2 SYSTEM IDENTIFICATION

### 2.3.2 SDI/DDI Backplane

The SDI/DDI Backplane is shown in **Figure 8** below. Identifying features are the two 32-pin DIN connectors and 20-pin transformer connector. The 2-pin locking connector may not be present on some systems.

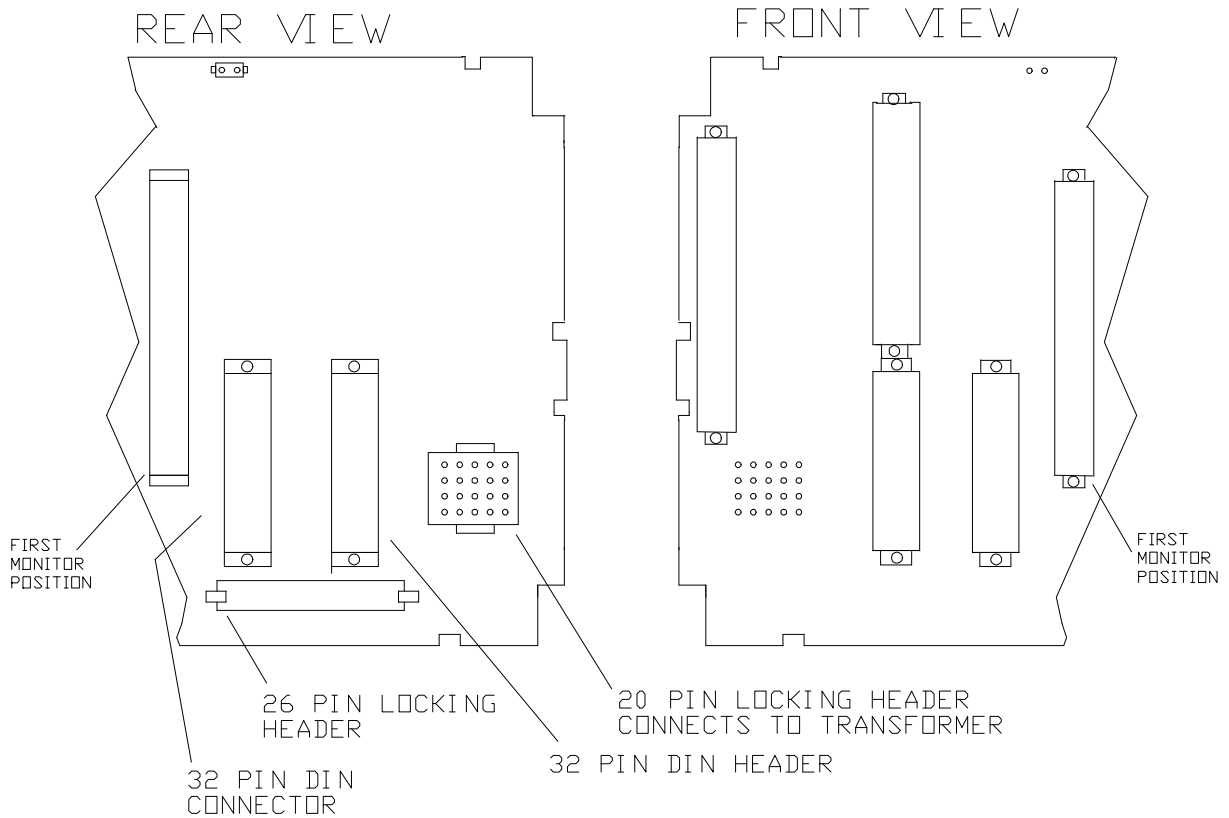

Figure 8  
SDI/DDI Backplane

## 2 SYSTEM IDENTIFICATION

### 2.4 Monitor Firmware Identification

Part numbers for SDI/DDI monitor firmware are shown in **Table 3** below. Firmware resides in either an EPROM or in the microprocessor ROM.

- The 3300/90 Diagnostic Instrument and the 3300/60 Vector Monitor are not supported by SDI/DDI.
- The original firmware in the 3300/17, 3300/36, 3300/39, 3300/40, 3300/52, 3300/53, 3300/54, 3300/75, 3300/80, 3300/81, 3300/85, and 3300/95 monitors is SDI/DDI compatible.

Monitor Number	SDI/DDI Compatible EPROM Part Number	SDI/DDI Compatible Single-chip Microprocessor Part Number
3300/15	N/A	104044-01
3300/16	N/A	00800119
3300/20	N/A	00800120
3300/25	N/A	104044-02
3300/26	N/A	104044-03
3300/30 <sup>1</sup>	89809-01	142591-01
3300/35 <sup>1</sup>	89818-01	142592-01
3300/45 <sup>1</sup>	89836-01	142783-01
3300/46 <sup>1</sup>	89845-01	142784-01
3300/47 <sup>1</sup>	89854-01	142785-01
3300/48 <sup>1</sup>	89863-01	142786-01
3300/50-XX	89872-01	104046-XX
3300/55	N/A	104044-04
3300/61	89890-01	N/A
3300/65 <sup>1</sup>	89899-01	142637-01
3300/70	N/A	104044-05

ALL revisions of above mentioned EPROM and microprocessor numbers are SDI/DDI compatible.  
**N/A** = SDI/DDI compatible firmware not available in specified format.  
**NOTE:** 1. These monitors were changed from EPROM to single-chip microprocessor formats. There were NO changes to the firmware in these monitors – only hardware changes. Either the EPROM or microprocessor listed are SDI/DDI compatible.  
**NOTE:** See Appendix B for the list of firmware upgrade kit part numbers for the individual monitors.

## 2 SYSTEM IDENTIFICATION

Use the following steps to check the firmware part number for the monitors in **Table 3**.

1. Disassemble the monitor by following the steps in the appropriate monitor manual. The microprocessor is located on the main circuit board that slides into the rack card guides. The EPROM is either on a small board, which plugs into the main board or is on the main board. The part number is marked on the EPROM or microprocessor.
2. Locate the EPROM or microprocessor on the circuit board by referring to the following sketches:

**Firmware on the plug-in Memory Board**

The following monitors have firmware installed in the EPROM located on a small plug in board (as shown in **Figure 9**):

- 3300/50-01
- 3300/50-02
- 3300/50-03

Only the part numbers in **Table 3** are SDI/DDI compatible. See Appendix B for a list of firmware upgrade kit Part Numbers.

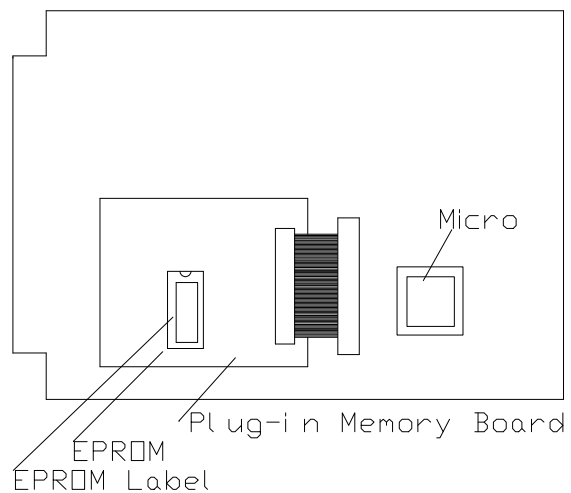

**Figure 9**  
Expander Board Location

**Firmware in the Microprocessor**

These monitors have firmware installed in either the microprocessor ROM (a shown in **Figure 10**) or in the EPROM located on a small plug in board (as shown in **Figure 9**):

- |         |         |
|---------|---------|
| 3300/15 | 3300/45 |
| 3300/16 | 3300/46 |
| 3300/20 | 3300/47 |
| 3300/25 | 3300/48 |
| 3300/26 | 3300/55 |
| 3300/30 | 3300/65 |
| 3300/35 | 3300/70 |

Only the part numbers in **Table 3** are SDI/DDI compatible. See Appendix B for a list of firmware upgrade kit Part Numbers.

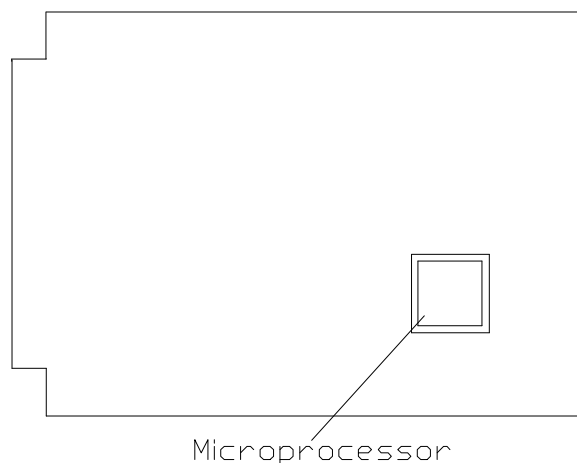

**Figure 10**  
Microprocessor Location

## 2 SYSTEM IDENTIFICATION

### Firmware in the 3300/61 Dual Vector Monitor

The firmware for the 3300/61 Dual Vector Monitor is located in an EPROM on the main circuit board as shown in **Figure 11**.

Only the firmware in **Table 3** is SDI/DDI compatible. See Appendix B for the firmware upgrade kit Part Number.

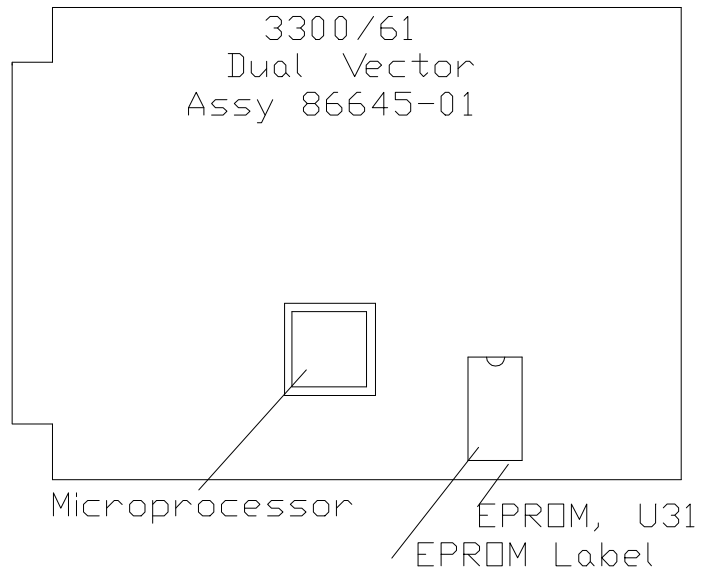

**Figure 11**

**Figure 11**  
EPROM Location on 3300/61

- If the individual monitor firmware is not SDI/DDI-compatible and you plan to use either internal SDI/DDI communications (through a 3300/03-02 or -03 System Monitor), or an external SDI/DDI-compatible CP (SDIX/DDIX, TDIX, or TDXnet) with your 3300 system, then you must contact your Bently Nevada representative to order firmware upgrade kits.

## 3 SYSTEM COMPATIBILITY

Use this section to determine which components will or will not work in your system. Refer to Section 2 and/or **Table 2** to determine which system configuration you have.

See **Table 4** for compatibility between each System Monitor and the different Communications Processors and Software.

See **Appendix A** for the list of hardware upgrade kit part numbers.

See **Appendix B** for a list of firmware upgrade kit part numbers for the different monitors.

### 3.1 Mixed System Compatibility Issues

- If a Mixed System is being used with a DDM, TDM or PDM CP, the firmware in the individual monitors does **not** need to be SDI/DDI compatible.
- In order for the Mixed System to be compatible with the external communication processors (SDIX/DDIX, TDIX or TDXnet) and DM2000 software, the firmware in all of the monitors must be SDI/DDI compatible. See **Table 3** for SDI/DDI compatible firmware.

### 3.2 Additional Compatibility Issues

#### 3.2.1 Monitors

- The original firmware in the 3300/17, 3300/36, 3300/39, 3300/40, 3300/52, 3300/53, 3300/54, 3300/75, 3300/80, 3300/81, 3300/85, and 3300/95 monitors is SDI/DDI compatible.
- The 3300/75, /80 and /81 monitors support SDI(X)/DDI(X), TDIX, and TDXnet CPs only.
- The 3300/75, /80 and /81 monitors are compatible with only the 3300/01-01 and 3300/03-XX System Monitors.
- The 3300/90 Diagnostic Instrument and the 3300/60 Vector Monitor are not supported by SDI/DDI.

#### 3.2.2 Communications Processors

If a TDM communications processor is on the same communications chain with a TDIX or TDXnet communication processor, and the TDM firmware is Rev C or earlier, the TDM firmware will need to be upgraded. Contact your Bently Nevada Corporation representative to order a firmware upgrade kit for your TDM communications processor.

## 3 SYSTEM COMPATIBILITY

### 3.3 Communication Processor and Software Compatibility

<b>Table 4</b>					
Communication Processor and Monitoring Software Compatibility					
Communications Processor or Software	System Monitor				
	3300/01-01	3300/01-02 <sup>5</sup>	3300/03-01	3300/03-02 <sup>7</sup> (Internal SDI)	3300/03-03 <sup>7</sup> (Internal DDI)
DDM CP	C	C	C	NC	NC
TDM CP	C	C	C	NC	NC
PDM CP	C	C	C	NC	NC
SDIX/DDIX CP	NC	NC	C	NC	NC
TDIX CP	NC	NC	C <sup>8</sup>	NC <sup>8</sup>	NC <sup>8</sup>
TDXnet CP	NC	NC	C <sup>8</sup>	NC <sup>8</sup>	NC <sup>8</sup>
DDM/TDM Software	C <sup>1</sup>	C <sup>1</sup>	C <sup>1</sup>	NC	NC
DDM2/TDM2 Software <sup>4</sup>	C <sup>1</sup>	C <sup>1</sup>	C <sup>3</sup>	C <sup>3</sup>	C
DM2000 Software	C <sup>1</sup>	C <sup>1</sup>	C <sup>6</sup>	C <sup>8</sup>	C <sup>4,8</sup>
Host System using Allen-Bradley or Modicon Modbus Communication Protocol	C <sup>1</sup>	C	C <sup>2</sup>	C	C

**NOTES**

C = compatible NC = not compatible

1. A DDM or TDM CP must be installed.
2. Use with a TDIX or TDXnet CP OR upgrade to a 3300/03-02 SDI.
3. Use with a TDM or TDIX CP OR upgrade to a 3300/03-03 DDI.
4. DDI can be daisy-chained with DDI, DDM, TDM, PDM and TDIX CPs. Refer to the Serial Data Interface/Dynamic Data Interface Manual, Bently Nevada Corporation part number 89541-01, for details on daisy chaining 3300 racks and cabling requirements.
5. Host software developed for the 3300/01-02 Serial Interface System Monitor will work with the SDI but the additional features of the SDI will not be available to the host unless the software is updated.
6. Use with a DDM, TDM, TDIX or TDXnet CP OR upgrade to 3300/03-03 DDI.
7. The internal SDI/DDI communication protocols MUST be disabled (configured as a 3300/03-01) in order to connect to an external CP.
8. In order to communicate with a TDIX or TDXnet CP, the firmware in EACH monitor MUST be SDI/DDI compatible.

## 4 APPENDIX A

### 4.1 Hardware Upgrade Kit Part Numbers

Monitor	Hardware Upgrade Kit Part Number
Original or Mixed System to SDI/DDI System	104002
3300/03-01 System Monitor to 3300/03-02 SDI System Monitor	143121-01
3300/03-02 SDI System Monitor to 3300/03-03 SDI/DDI System Monitor	143121-02
3300/03-01 System Monitor to 3300/03-03 SDI/DDI System Monitor	143121-03

## 5 APPENDIX B

### 5.1 Firmware Upgrade Kit Part Numbers

To upgrade to an SDI/DDI compatible monitor

Monitor or Communication Processor Part Number	Firmware Upgrade Kit Part Number
3300/01-02	101412-01
3300/03-02 SDI System Monitor	137374
3300/15 Dual Vibration Monitor	104535-01
3300/16 Dual Vibration w/Gap Monitor	104535-02
3300/20 Dual Thrust Position Monitor	104535-03
3300/25 Dual Accelerometer Monitor	104535-04
3300/26 Dual Accelerometer RMS Monitor	104535-05
3300/30 Six-channel Thermocouple Input Temperature Monitor	104535-06
3300/35 Six-channel RTD Input Temperature Monitor	104535-07
3300/40 Eccentricity Monitor	139028-01
3300/45 Dual Differential Expansion Monitor	104535-08
3300/46 Ramp Differential Expansion Monitor	104535-09
3300/47 Complementary Input Differential Expansion Monitor	104535-10
3300/48 Case Expansion Monitor	104535-11
3300/50-01 Dual Setpoint Tachometer	104535-12
3300/50-02 Zero Speed Tachometer	104535-17
3300/50-03 Rotor Acceleration Tachometer	104535-18
3300/54 Dual REBAM Monitor	125507-01
3300/55 Dual Velocity Monitor	104535-13
3300/61 Dual Vector Monitor	104535-14
3300/65 Dual Probe Monitor	104535-15
3300/70 Dual Valve Position Indicator	104535-16
3300/80 Rod Drop Monitor	105238-01