

3.14 PRTD Resistance Temperature Device Input Module

The following I/O pack and terminal board combinations are approved for use in hazardous locations:

- RTD input pack **IS220PRTDH1A** or **IS220PRTDH1B** with terminal board **IS200TRTDH2D**, **IS200SRTDH1A**, or **IS200SRTDH2A**
- Coated RTD input pack **IS221PRTDH1B** with terminal board **IS201TRTDH2D**, **IS201SRTDH1A**, or **IS201SRTDH2A**

3.14.1 Electrical Ratings

Item	Min	Nominal	Max	Units
<i>Power Supply</i>				
Voltage	27.4	28.0	28.6	V
Current	—	—	0.24	A
<i>RTD Inputs</i>				
Voltage	0	—	4.2	V
Current	—	10.0	—	mA

3.14.2 Field Wire Connections

Terminal Board	Terminal Block Type
SRTD	Refer to the table Euro Style Box-type Terminal Blocks for wire size and screw torques.
TRTD	Refer to the table Barrier-type Terminal Blocks for wire size and screw torques.

3.14.3 Intrinsic Safety “ic”

Wiring Diagram

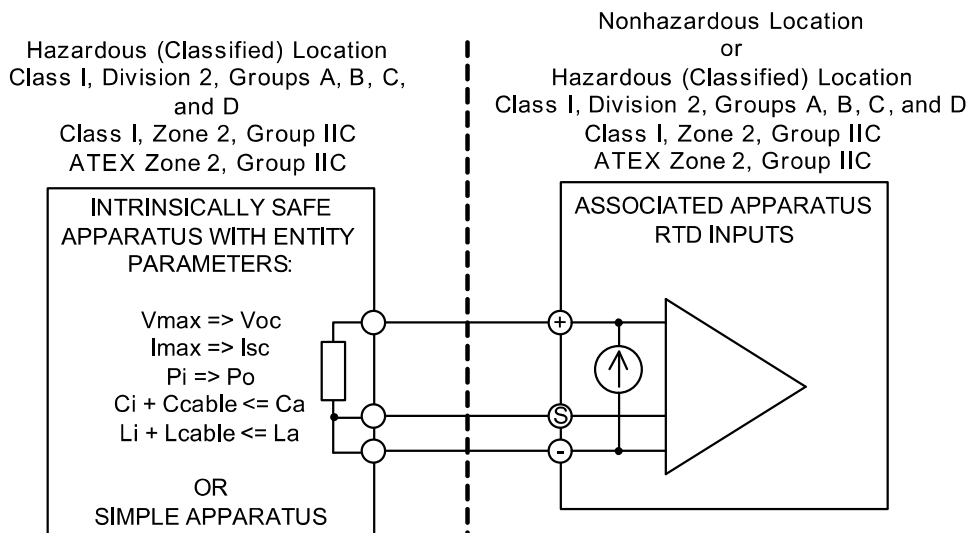

Mark VIe I/O Modules Classified Location Certifications (continued)

Equipment	Non-hazardous	Class I, Division 2, Groups A, B, C, D	Class I, Zone 2, Group IIC	ATEX Zone 2, Group IIC
IS220PPRAS1A Accessories: IS200TREAS1A IS200WREAS1A	UL E207685	UL E207685	UL E207685	UL DEMKO 12 ATEX 1114875X
IS220PPRAS1B Accessories: IS200TREAS1A IS200WREAS1A	UL E207685	UL E207685	UL E207685	UL DEMKO 13 ATEX 1214780X
IS220PPRFH1A Accessories: IS200SPIDG1A	UL E207685	UL E207685	UL E207685	UL DEMKO 12 ATEX 1114875X
IS220PPRFH1B Accessories: IS200SPIDG1A	UL E207685	UL E207685	UL E207685	UL DEMKO 13 ATEX 1214780X
IS220PROH1A Accessories: IS200SPROH1A IS200SPROH2A IS200TPROH1C IS200TPROH2C IS200TREATH1A IS200TREATH3A	UL E207685	UL E207685	UL E207685	UL DEMKO 12 ATEX 1114875X
IS220PPROS1B Accessories: IS200SPROH1A IS200SPROH2A IS200TPROH1C IS200TPROH2C IS200TPROS1C IS200TPROS2C IS200TREATH1A IS200TREATH3A	UL E207685	UL E207685	UL E207685	UL DEMKO 13 ATEX 1214780X
IS220PRTDH1A Accessories: IS200TRTDH2D IS200SRTDH1A IS200SRTDH2A	UL E207685	UL E207685	UL E207685	UL DEMKO 12 ATEX 1114875X

Mark VIe I/O Modules Classified Location Standards (continued)

Equipment	Non-hazardous	Class I, Division 2, Groups A, B, C, D	Class I, Zone 2, Group IIC	ATEX Zone 2, Group IIC
IS220PPRFH1A Accessories: IS200SPIDG1A	UL 508 Ed. 17 CSA-C22.2 No. 142-M1987	ANSI/ISA-12.12.01-2015 CAN/CSA-C22.2 No. 213-15	UL 60079-0 Ed. 5 UL 60079-15 Ed. 3 CAN/CSA-C22.2 No. 60079-0:11 CAN/CSA-C22.2 No. 60079-15:12	EN 60079-0:2012 EN 60079-15:2010
IS220PPRFH1B Accessories: IS200SPIDG1A	UL 508 Ed. 17 CSA-C22.2 No. 142-M1987	ANSI/ISA-12.12.01-2015 CAN/CSA-C22.2 No. 213-15	UL 60079-0 Ed. 5 UL 60079-15 Ed. 3 CAN/CSA-C22.2 No. 60079-0:11 CAN/CSA-C22.2 No. 60079-15:12	EN 60079-0:2012 EN 60079-15:2010
IS220PPROH1A Accessories: IS200SPROH1A IS200SPROH2A IS200TPROH1C IS200TPROH2C IS200TREATH1A IS200TREATH3A	UL 508 Ed. 17 CSA-C22.2 No. 142-M1987	ANSI/ISA-12.12.01-2015 CAN/CSA-C22.2 No. 213-15	UL 60079-0 Ed. 5 UL 60079-15 Ed. 3 CAN/CSA-C22.2 No. 60079-0:11 CAN/CSA-C22.2 No. 60079-15:12	EN 60079-0:2012 EN 60079-15:2010
IS220PPROS1B Accessories: IS200SPROH1A IS200SPROH2A IS200TPROH1C IS200TPROH2C IS200TPROS1C IS200TPROS2C IS200TREATH1A IS200TREATH3A	UL 508 Ed. 17 CSA-C22.2 No. 142-M1987	ANSI/ISA-12.12.01-2015 CAN/CSA-C22.2 No. 213-15	UL 60079-0 Ed. 5 UL 60079-15 Ed. 3 CAN/CSA-C22.2 No. 60079-0:11 CAN/CSA-C22.2 No. 60079-15:12	EN 60079-0:2012 EN 60079-15:2010
IS220PRTDH1A Accessories: IS200TRTDH2D IS200SRTDH1A IS200SRTDH2A	UL 508 Ed. 17 CSA-C22.2 No. 142-M1987	ANSI/ISA-12.12.01-2015 CAN/CSA-C22.2 No. 213-15	UL 60079-0 Ed. 5 UL 60079-15 Ed. 3 CAN/CSA-C22.2 No. 60079-0:11 CAN/CSA-C22.2 No. 60079-15:12	EN 60079-0:2012 EN 60079-11:2012 EN 60079-15:2010

Mark VIe I/O Modules Equipment Markings (continued)

Equipment	US & CAN Class I Div 2	US & CAN Class I Zone 2	ATEX Zone 2
IS220PRTDH1A Accessories:	Class I, Div 2, Groups A, B, C, D, T4	Class I, Zone 2, AEx nA [nC] IIC T4, Ex nA [nL] IIC T4 Gc X	Ex nA [ic] IIC T4 Gc
IS200TRTDH2D			
IS200SRTDH1A			
IS200SRTDH2A			
IS220PRTDH1B Accessories:	Class I, Div 2, Groups A, B, C, D, T4	Class I, Zone 2, AEx nA [nC] IIC T4, Ex nA [nL] IIC T4 Gc X	Ex nA [ic] IIC T4 Gc
IS200TRTDH2D			
IS200SRTDH1A			
IS200SRTDH2A			
IS221PRTDH1B Accessories:	Class I, Div 2, Groups A, B, C, D, T4	Class I, Zone 2, AEx nA [nC] IIC T4, Ex nA [nL] IIC T4 Gc X	Ex nA [ic] IIC T4 Gc
IS201TRTDH2D			
IS201SRTDH1A			
IS201SRTDH2A			
IS220PSCAH1A Accessories:	Class I, Div 2, Groups A, B, C, D, T4	Class I, Zone 2, AEx nA IIC T4, Ex nA IIC T4 Gc X	Ex nA IIC T4 Gc
IS200SSCAH1A			
IS200SSCAH2A			
IS220PSCAH1B Accessories:			
IS200SSCAH1A			
IS200SSCAH2A			
IS221PSCAH1B Accessories:	Class I, Div 2, Groups A, B, C, D, T4	Class I, Zone 2, AEx nA IIC T4, Ex nA IIC T4 Gc X	Ex nA IIC T4 Gc
IS201SSCAH1A			
IS201SSCAH2A			
IS42yPSCAH1B Accessories:			
IS40ySSCAH1A			
IS40ySSCAH2A			
IS220PSVOH1A Accessories:	Class I, Div 2, Groups A, B, C, D, T4	Class I, Zone 2, AEx nA nC IIC T4, Ex nA nL IIC T4 Gc X	Ex ic nA IIC T4 Gc
IS200TSVCH2A			
IS210WSVOH1A			

Appendix D Ambient Temperature Ratings

Note In the following tables, **y** = 0 or 1 for module part numbers.

Ambient Temperature Ratings

GE Part Number	Ambient Temperature Rating
IS200JPDLG1A	
IS210BAPAH1A	
IS220PAICH1A	
IS220PAOCH1B	
IS220PCLAH1A	
IS220PCLAH1B	
IS220PDIAH1A	
IS220PDIIH1B	
IS220PDIOH1A	
IS220PDIOH1B	
IS220PDOAH1A	
IS220PHRAH1A	
IS220PHRAH1B	
IS220PPDAH1A	
IS220PPRAH1A	
IS220PPRAS1A	
IS220PPRAS1B	
IS220PPROH1A	
IS220PPROS1B	
IS220PRTDH1A	
IS220PRTDH1B	
IS220PSCAH1A	
IS220PSCAH1B	
IS220PSCHH1A	
IS220PSVOH1A	
IS220PSVOH1B	
IS220PTCCH1A	
IS220PTCCH1B	
IS220PTURH1A	
IS220PTURH1B	
IS220PVIBH1A	
IS220YAICS1A	
IS220YDIAS1A	
IS220YDOAS1A	
IS220YHRAS1A	
IS220YPROS1A	
IS220YSILS1A	
IS220YSILS1B	
IS220YTCCS1A	
IS220YTURS1A	
IS220YVIBS1A	
IS221PHRAH1B	

-30 to + 65 °C (-22 to +149 °F)