

1 General

1.1 Using this manual

This manual contains information concerning the use of the device.

Read the operating manual completely prior to starting installation and operating the device. Comply with all safety instructions.

This operating manual applies for CON 021, CON 031, CON 021/..., and CON 031/... Converters with serial number 20xx/07-xxxxxx (hardware revision 07). See type plate for serial number.

Include the operating manual when transferring the device to third parties.

Note

When requesting technical support, please indicate type and serial number from the type plate.

Table 1-1 shows a list of documents that are referred to in this operating manual.

Table 1-1: Referenced documents

MHM-97866	Installation Guide PR642x, Eddy Current Sensors
-----------	---

1.2 Symbols

Note

This symbol marks passages that contain important information.

CAUTION

This symbol marks operations that can lead to malfunctions or faulty measurements, but will not damage the device.

DANGER

A danger indicates actions that can lead to property damage or personal injury.

	According to IEC 61010, this symbol means that this device must be operated with DC voltage.
---	--

	According to IEC 61010, this symbol means that the documentation of the device must completely be read and understood before installing and commissioning of the device. Observe all safety related instructions in this document.
---	--

1.3 Liability and guarantee

Emerson is not liable for damages that occur due to improper use. Proper use also includes the knowledge of, and compliance with, this document.

Customer changes to the device that have not been expressly approved by Emerson will result in the loss of guarantee.

Due to continuous research and further development, Emerson reserves the right to change technical specifications without notice.

1.4 Incoming goods inspection

Check the content of the shipment to ensure that it is complete; visibly inspect the goods to determine if the device has been damaged during transport. The following parts are included in the scope of delivery and must be contained in the shipment.

- CON 021, CON 031, CON 021/..., or CON 031/... Converter
- Installation guide

If the contents are incomplete, or if you observe any defects, file a complaint with the carrier immediately. Inform the responsible Emerson sales organization so your device can be replaced. In this case, attach a tag with customer name and the observed defect.

1.5 Technical support

You may need to ship this product for return, replacement, or repair to an Emerson Product Service Center. Before shipping this product, contact Emerson Product Support to obtain a Return Materials Authorization (RMA) number and receive additional instructions.

Product Support

Emerson provides a variety of ways to reach your Product Support team to get the answers you need when you need them:

Phone	Toll free 1 800 833 8314 (U.S. and Canada) +1 512 832 3774 (Latin America) +63 2 8702 1111 (Asia Pacific, Europe, and Middle East)
Email	Guardian.GSC@Emerson.com
Web	http://www.emerson.com/en-us/contact-us

To search for documentation, visit <http://www.emerson.com>.

To view toll free numbers for specific countries, visit <http://www.emerson.com/technicalsupport>.

Note

If the equipment has been exposed to a hazardous substance, a Material Safety Data Sheet (MSDS) must be included with the returned materials. An MSDS is required by law to be available to people exposed to specific hazardous substances.

3 Application and design

3.1 Application

The CON 021 or CON 031 Signal Converters in combination with sensors of type PR 6422 to PR 6426 form eddy current measuring chains to be used for static and dynamic distance measurements at all kinds of rotating machinery. This means that slow axial displacements as well as fast radial vibrations of rotating machines can be measured. By using pulse wheels or key marks stuck on the shaft, the speed of the machine can be measured and key pulses generated.

Sensors and signal converters are adjusted together and are delivered as complete measuring chains in order to achieve a maximum accuracy. For this reason it is important to always operate sensors and converters together. The type of the sensor and its serial number are marked on the type plate of the converter.

The characteristics of the measuring chain are adapted to the material mainly used for turbo machinery (reference material: 42 Cr Mo 4, according to SAE 4140). The standard adjustment of the measuring chains is generally related to this material – if necessary, other materials can be used for the adjustment (see installation guide PR 642x, Eddy Current Sensors). During installation at the machine only the distance between the head of the sensor and the measuring target are to be adjusted. Criterion for the adjustment of the sensor is the output signal of the converter.

Supply circuits for the eddy current sensor and the measuring electronic are contained in the converter. The nominal supply voltage for the converter is -24 V DC, the nominal range of the output signal, proportional to the nominal measuring range of the sensor, may be set to either -4 to -20 V or -2 to -18 V. The output voltage of converters for special measuring ranges (CON 021 / 91x-xxx or CON 031 / 91x-xxx) have a firmly adjusted range of -4 to -20V.

Five eddy current probes are at disposal. The actual type to be used depends on the measuring range, on the available space for measuring and on the environmental temperature.

3.2 Design

The CON 021 and CON 031 signal converters are accommodated in a simple housing prepared for the installation in a mounting box. Connection of the eddy current probe to the CON 021 is made with a LEMO connector at the front of the converter (see [Figure 3-1](#)), the CON 031 is provided with screw terminals for transducers without connector (see [Figure 3-2](#)). See [Figure 3-3](#) for details of an open CON 021. The component layout of CON 031 is identical to the layout of the CON 021.

5 Extended measuring ranges

For larger measuring ranges use CON 021/91x-xxx or CON 031/91x-xxx converters. [Table 5-1](#) shows the available extended measuring ranges depending on the used sensor type and the resulting sensitivity of the measuring chain.

Table 5-1: Extended measuring ranges

Sensor	Extended measuring range	Sensitivity
PR 6422	1.5 mm	-10.67 V/mm
PR 6423	3.0 mm	-5.33 V/mm
	4.0 mm	-4.0 V/mm
PR 6424 and PR 6425	6.0 mm	-2.67 V/mm
	8.0 mm	-2.0 V/mm
	10.0 mm	-1.6 V/mm
PR 6426	12.0 mm	-1.33 V/mm
	16.0 mm	-1.0 V/mm
	20.0 mm	-0.8 V/mm
	24.0 mm	-0.67 V/mm

The output voltage range of converters with extended measuring range is generally -4 V to -20 V. The wire bridge for changing the output voltage range is missing at converters with extended measuring range because of the fixed output voltage range (see [Figure 3-3](#)). See [Figure 5-1](#) for decoding of the converter designation.

Figure 5-1: Designation of converter with extended measuring range

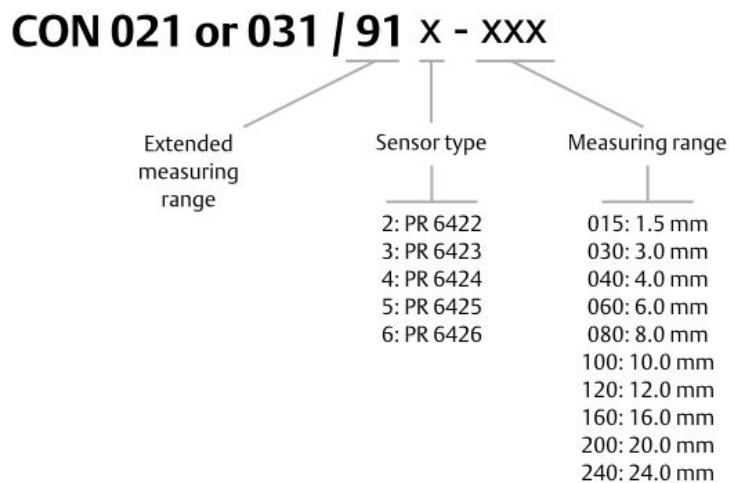

6.2 Adjustment of measuring chains at the machine

6.2.1 General connection

Procedure

1. Connect the converter supply -24 V DC (+24 V to \perp).
2. Fit connector of sensor to converter input.
3. Measure output level at pins OUT and \perp .

6.2.2 Sensors PR 6422, PR 6423, PR 6424, and PR 6425

Procedure

1. Loosen the lock nut from the sensor.
2. Remove the sensor cable to avoid twisting of the cable during mounting and turning the sensor.
3. Turn the sensor in the holder as long as the nominal distance between sensor head and measuring target is reached and the connected voltmeter indicates the desired point on the characteristic curve.
 - For measuring shaft vibrations it is sufficient to adjust the sensor to an output value of $-10\text{V} \pm 1\text{ V}$ (output range -2 V to -18 V) or $-12\text{V} \pm 1\text{ V}$ (output range -4 V to -20 V). See [Figure 6-2](#).
 - For static measurements a precise adjustment to one output value is required, the sensor is preferably set to one of the three output levels of the converter:
For symmetrical displacements around the center point (see [Figure 6-3, F](#)) to -12V (-4 V to -20 V) or -10V (-2 V to -18 V) $\pm 0.05\text{ V}$ (recommended procedure) for the measuring range minimum (= minimum distance) to -4V (-4 V to -20 V) or -2V (-2 V to -18 V) $\pm 0.05\text{ V}$ for single-sided movements to greater distances ([Figure 6-3, E](#))
for the measuring range maximum (= maximum distance) to -20V (-4 V to -20 V) or -18V (-2 V to -18 V) $\pm 0.05\text{ V}$ for single sided movements to smaller distances. ([Figure 6-3, G](#))
or to any other value within the measuring range when different distances in both directions must be measured.

Figure 6-3: Characteristic curve - static

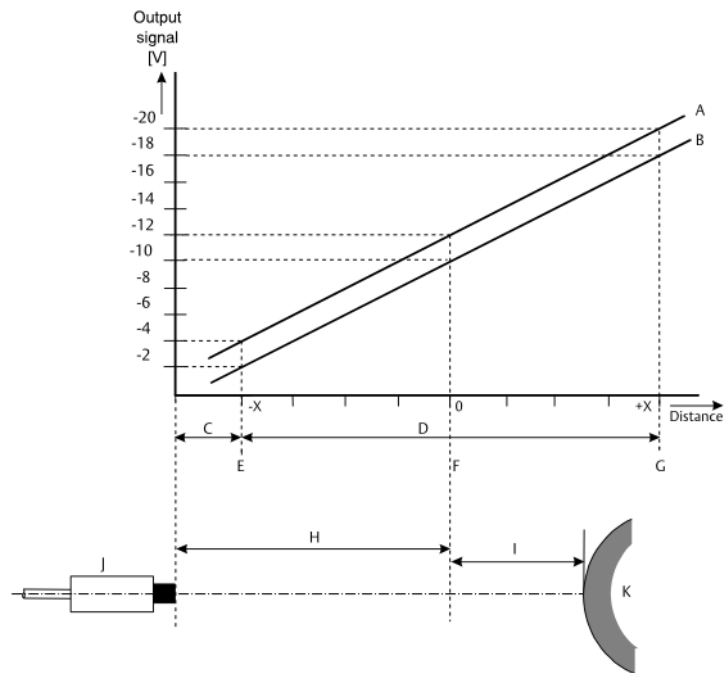

- A. Characteristic curve -2 V to -18 V
- B. Characteristic curve -4 V to -20 V
- C. Basic air gap / zero gap
- D. Working range (-x to +x)
- E. Minimum distance
- F. Center point
- G. Maximum distance
- H. Nominal distance
- I. Instantaneous distance
- J. Sensor
- K. Shaft

4. Fix the sensor by means of the lock nut. The maximum torque is:
 - PR 6422: 1 Nm (0.1 kpm)
 - PR 6423: 15 Nm (1.5 kpm)
 - PR 6424 and PR 6425: 100 Nm (10 kpm)

6.2.3 Sensor PR 6426

If the distance between mounting flange and measuring target is not correct, adjust it by shifting the mounting flange (see PR 642x Installation Guide MHM-97866, chapter "PR 6426 installation"). In order to achieve a precise adjustment, Emerson recommends using

Table 6-1: Factor for distance calculation (continued)

Sensor type	Factor x de-tuned	Factor x tuned
PR 6423/xxx-xxx	2.5	3
PR 6424/xxx-xxx	1	2

Example for PR 6423 with sensor head diameter of 8 mm:

Minimum Distance_{de-tuned} = 8 mm * 2.5 = 20 mm

Minimum Distance_{tuned} = 8 mm * 3 = 24 mm

6.4 Recalibration of the converter (only necessary in special cases)

Prerequisites

- Calibration gauge (for example CAL 064) with micrometer screw gauge and material sample that matches the material of the measuring target (machine shaft).
- Multimeter with an accuracy of 1%
- Two resistance decades and connection cables
- Assortment of resistors (resistor series E48, 0.6W, accuracy 1%, temperature coefficient 50, axial leaded - for example, MRS25MBB0207 or SMA0207)
- Soldering iron and tin-solder
- +24V DC power supply
- Screwdriver for recessed-head screws (screw terminals)
- Small screwdriver for recessed-head screws (housing screws)

Figure 6-5 shows the calibration setup.

- a) Unscrew the recessed-head screws at the right housing side (see [Figure 6-6](#) for screw location).
- b) Pull out the printed circuit board.

Figure 6-6: Screws for opening the housing

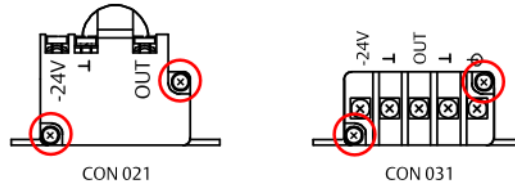

2. Desolder resistance R22 (gain factor, approximately 0 to 10 kΩ) and R23 (zero point, approximately 10 kΩ to 200 kΩ) and connect resistance decades to these positions. Set potentiometer GAIN (R25) to center position.
Resistance R24 depends on the sensor type: PR 6422 / 6423 / 6425: 4.02 kΩ, PR 6424: 5.62 kΩ, and PR 6426: 10 kΩ. See [Figure 6-7](#) for position of the calibration elements.

Figure 6-7: Position calibration elements

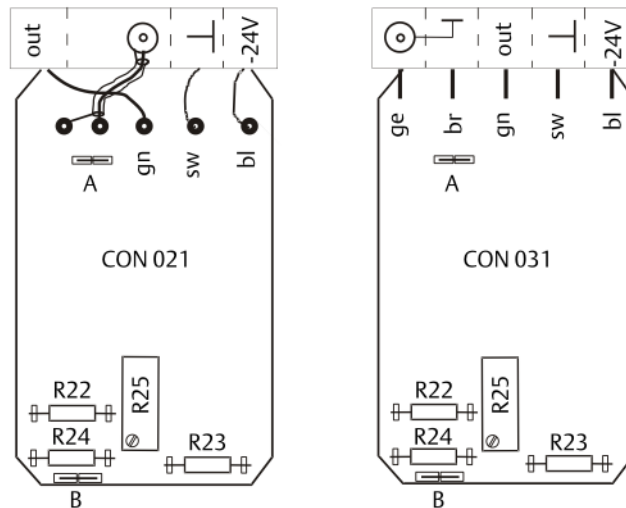

A. Wire bridge for change of oscillator frequency.
closed: approximately 1.25 MHz
open: +20% / 1.5MHz

B. Wire bridge for change of voltage output range.
closed: -2 V to -18 V
open: -4 V to -20 V

Not available for CON 021/91x-xxx and CON 031/91x-xxx converters.

3. Set the distance measuring target – sensor head to minimum gap (PR 6423: 500 μm, refer to PR64x Installation Guide for minimum gap of further sensors)

8 Technical data

Only specifications with indicated tolerances or limit values are required. Data without tolerances or without error limits are informative data and not guaranteed. Technology is under constant development, and specifications are subject to change without notice. If not stated otherwise, the specifications are valid for the nominal supply voltage of -24V.

8.1 Input

Connection for eddy current sensors. Self locking LEMO socket (CON 021) or screw terminals (CON 031) for connection of Emerson sensors PR 6422/xxx-xxx, PR 6423/xxx-xxx, PR 6424/xxx-xxx, PR6424/xxx-xxx, and PR 6426/xxx-xxx.

8.2 Supply

Supply voltage range	-23 to -28 V for output voltage range -4 to -20 V
	-21 to -28 V for output voltage range -2 to -18 V
	-18 to -21 V with reduced output voltage range
Nominal supply current	<15 mA, with 10 kΩ load resistance
Reverse connect protection	Reverse connect protection of all 3 terminals (GND, Output, and -24 V)
Nominal operating frequency	approximately 1.25 MHz
De-adjustment of oscillator for adjacent arrangement of sensors	open wire bridge D in Figure 3-3 (delivery state: closed)

8.3 Output

DC voltage with superimposed AC signal corresponding to vibration or displacement of the shaft. Open-circuit and short-circuit proof.

Output voltage range	Wire bridge A in Figure 3-3 closed: -2 to -18 V (factory setting)
	Wire bridge A in Figure 3-3 open: -4 to -20 V
	adjusted with 100kΩ load resistance
Limit range	-1 to -22 V (at -24 V supply voltage)
Nominal frequency range	0 to 20 kHz (-3 dB) with C - load = 10 nF
	0 to 15 kHz (-3 dB) with C - load = 20 nF
Rise time	<15 μs, with C - load = 1 nF
Output impedance	approximately 100 Ω
Load resistance	nominal value 100 kΩ (for R = 10 kΩ, error <1%)

8.4 Errors and tolerances

Error of gain factor	<1 % in range 0 to 1000 Hz and with C - load <20 nF
Supply voltage response of output signal	<20 mV/V
Long term drift	0.3 % maximum (in range: -30 to +70°C)
Temperature response - on the average output signal	Thermal response converter (absolute deviation)
Temperature response - on the sensitivity factor	Temperature influence on sensitivity
Interferences	< 10 mV rms with 1nF C - load
Calibration	With soldered resistors and potentiometers in the converter an adjustment on several sensor types and target materials is possible. The adjustment is made at the factory, but may be made by the customer or by a service engineer on site if special adjustment tools are available. See Recalibration of the converter (only necessary in special cases) for the adjustment procedure.

Errors of the measuring chain

These error definitions are related to the nominal measuring range (reference value). Linearity errors are defined as deviations from the linear curve, which crosses the -10 V value (-12 V if wire bridge A in [Figure 3-3](#) is open) and which gradient is defined by the nominal sensitivity.

Table 8-1: Absolute linearity errors for standard measuring ranges

Sensor type	Linearity error
PR 6422	≤ ±1.5 %
PR 6423	≤ ±1 %
PR 6424	≤ ±1.5 %
PR 6425	≤ ±0 to -6 %
PR 6426	≤ ±1.5 %

[Table 8-2](#) shows absolute linearity errors and sensor temperature influence for extended measuring ranges (CON 021/91x-xxx or CON 031/91x-xxx).

Table 8-2: Absolute linearity errors and sensor temperature influence for extended measuring ranges

Sensor type	Measuring range [mm]	Special version	Linearity failure [%]	Temperature failure ¹ [%/10K]	Initial Air Gap [mm] (approximately)
PR 6422	1.5	912-015	±2.00	±1.8	0.6
PR 6423	3	913-030	±1.50	±1.4	0.8

Table 8-2: Absolute linearity errors and sensor temperature influence for extended measuring ranges (continued)

Sensor type	Measuring range [mm]	Special version	Linearity failure [%]	Temperature failure ¹ [%/10K]	Initial Air Gap [mm] (approximately)
	4	913-040	±2.00	±1.8	1.0
PR 6424	6	914-060	±1.00	±0.7	1.0
	8	914-080	±1.50	±1.4	1.0
	10	914-100	±2.00	±2.6	1.0
PR 6425	4	915-040	±1.50		1.0
	6	915-060	±2.00	±1.5	1.0
	8	915-080	±3.00	±1.7	1.0
	10	915-100	±4.00	±3.0	1.0
PR 6426	12	916-120	±1.50	±2.2	1.5
	16	916-160	±2.00	±2.3	1.5
	20	916-200	±2.50	±2.8	1.5
	24	916-240	±3.50	±3.6	1.5

¹ Maximum temperature failure over the full sensor temperature range.

8.4.1 Thermal response converter (absolute deviation)

Table 8-3 and Table 8-4 show the converter temperature influence on the output voltage of the converter with standard measuring range as well as with extended measuring ranges. All values are based on +23°C. Sensors of type PR 6422 and PR 6426 have been used for completing the eddy current measuring chains. Due to their performance these sensors set the adjustment range for gain and zero point.

Table 8-3: Temperature influence - measurement with PR 6422

Temperature range [°C]	Middle voltage [V]	Output voltage range [V]	Deviation [mV]		
			Measuring Range		
			Standard	2x extended	3x extended
-35 to 10	-12 (-10 ¹)		0 / +1200	0 / +1800	0 / +2100
		-4 (-2 ¹) to -20 (-18 ¹)	0 / +1900	0 / +4300	0 / +6500
		-4 (-2 ¹) to -16 (-14 ¹) ²	0 / +1500	0 / +2700	0 / +4100
10 to 70	-12 (-10 ¹)		±200	+400 / -300	-300 / +300
		-4 (-2 ¹) to -20 (-18 ¹)	±200	+800 / -500	-900 / +800

CE – compatibility		Test according to: EN 55011(1998) & A1(1999) & A2(2001) (emitted interference) EN 61362(1997) & A1(1998) & A2(2001) & A3(2003) IEC 61326–1:2005 including EN 61000–4–5:2006 (interference resistance). The converter CON 021/... and CON 031/... meets the specifications mentioned above. The test specifications as setup, test levels, pass criteria, and so on, are described in the document “CON0x1_EMV –Testspezifikationen”. For copies of this document contact Emerson.	
Housing	Dimensions	see Figure 8-2 or Figure 8-3	
	Material	AlMgSi0,5F22	
Weight	net weight	CON 021: 95 g and CON 031: 85 g	
	with packing	CON 021: 0.56 kg and CON 031: 0.55 kg	

Figure 8-2: Dimensions CON 021

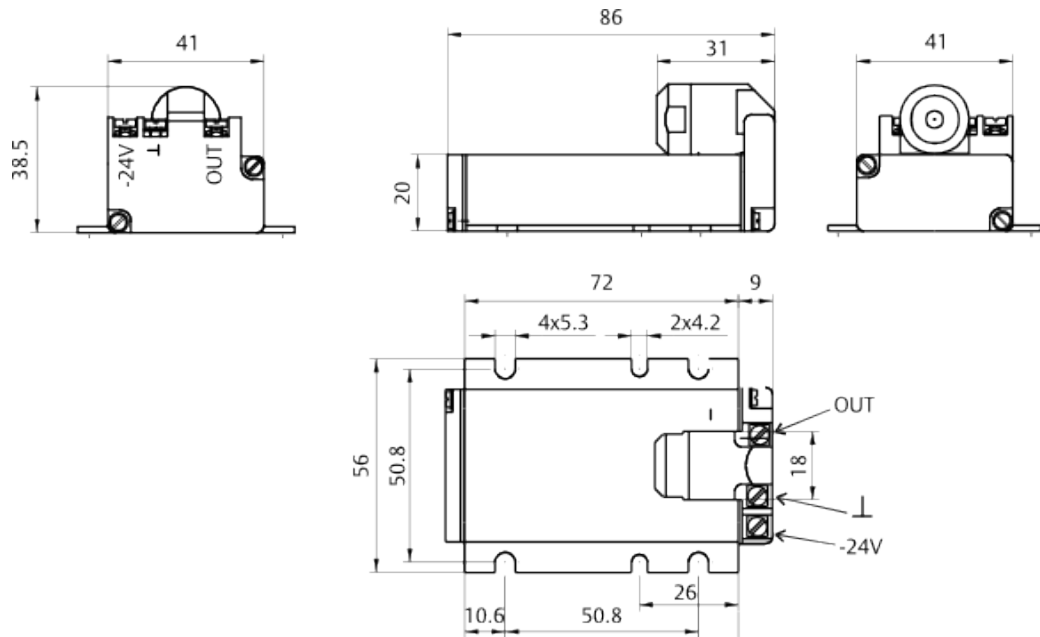

All dimensions in mm.

9 Explosion proof installation

Version 1.5

⚠ CAUTION

The ATEX and CSA certification is only valid for manufacturer-calibrated converters. Manufacturer-calibrated converters are labeled up with a CSA- and an Ex- conformity sticker. In case that no label is pasted, this converter does not have ATEX and/ or CSA conformity.

⚠ CAUTION

In relation to the nominal supply voltage of the 6000 monitors the nominal voltage of the Ex- barriers with $U_0 = -28V$ is a little bit lower.

To reduce unintentional and disturbing effects, it is necessary to wire up a diode module into the converter supply circuit. This diode must be implemented between the Ex-barrier and the 6000 module (see [Figure 9-1](#)). This diode module is delivered together with the Ex-barrier in a package. The order code for the package is 9500-00125.

Under consideration of the following conditions, the sensors PR 6422 ... PR 6426 together with the CON 021 /031 signal converter may be used for applications in hazardous areas for zone 1, protection class "Intrinsic safety" – Ex ia IIC T4:

Connection must be made according to [Figure 9-1](#) e.g. via safety barriers of type Stahl:

Supply circuit: 9001/00-280/085/101

Measuring circuit: 9001/00-280/020/101

The safety barriers must be installed outside the explosive area in cabinets or control cubicles with protection classes of at least IP 20 according to IEC 60529. With an appropriate approval the barriers can be also installed in zone 2. In this case the specifications of the manufacturer have to be observed.

In order to achieve compensations of electric potentials, the connectors for protective earth (mounting screw, internally connected to pin 2) must be linked to the corresponding protective earth connectors within the explosive areas via a compensation line. The mounting rail for the safety barriers has to be isolated.

Within the ATEX – field of application the compensation line has to be rated according to EN 60079-14 12.2.4 with minimum copper wire cross section $2 \times 1,5 \text{ mm}^2$ or $1 \times 4 \text{ mm}^2$. Outside of the ATEX – field of application the respectively valid installation instructions have to be observed.

The total capacity is calculated from the sum of the capacities at the sensor input, at the measuring signal output (between Out, \perp and screen) and at the supply input (-24 V , \perp and screen). The capacity of the sensor circuit is not effective, the capacity of the converter is 6,5 nF (refer to section [Technical data, explosion - proof technical data](#)).

The maximum permitted cable capacity and cable inductance between converter and safety barriers depends on the used barriers. The data of the following examples are

manufacturer's data¹ respectively has been calculated for use in Zone 1 by the program Ispark of the PTB² and are valid for the field of application of ATEX:

Supply Barrier	Evaluation Barrier	Permissible cable capacity (nF)		Permissible cable inductance (mH)	
		IIC	IIB	IIC	IIB
9002/00-260-138-001 ¹	9002/00-260-138-001	87,0 – 6,5 =70,5	670 – 6,5 =662,5	0,81 – 0,028=0,782	5,1 – 0,028 =5,072
9001/00-280/085/101 ²	9001/00-280/020/101	83,0 – 6,5 =76,5	230,0 – 6,5 =223,5	0,20 – 0,028=0,172	10,0 – 0,028=9,772
9001/00-280/100/101 ²	9001/00-280/020/101	–	220,0 – 6,5 =213,5	–	5,0 – 0,028 =4,772

- ¹ The barrier may be connected to a voltage supply of maximum -23,5 V, hence it can be only directly supplied from the 6000 system with an intercalated voltage reduction of minimum 3,2V (e.g. Z – diode 3,3 V).
- ² The barrier may be connected to a voltage supply of maximum -26,0 V. At supply from the 6000 system a diode has to be used (see above).

[Influence of safety barriers on the cable length](#) contains examples for cable length depending on the used safety barrier.

Note

When operating the CON 021 / 031 signal converter in hazardous areas, the following points have to be observed:

- The installation is only permitted in suitable protective housings which ensure that the converter isn't exposed to strokes or mechanical shocks and that friction of metallic parts at the converter housing is avoided.
- The calibration resistor R22 to R24 must not be changed by customers. A recalibration has to be made by the manufacturer. Soldering at a converter that is permitted for use in hazardous areas causes loss of this approval.
- If sensors with extension cables are used, the adapter plug has to be isolated with two shrink sleeves: First the black and additionally the blue shrink sleeve have to be shrank on the adapter plug.
- The transition resistance of housing to protective earth must not exceed 1 MOhm.

9.1 Special Requirements for CSA – approval installations

Note

Installation in protection class "ia":

- The installation has to be in accordance with the control drawing 9200-00006.

Installation in protection class "nA":

- The sensor may not be separated when energized.
- The used housing has to be in accordance with the requirements of CAN/CSA E60079-15-02 or UL 60079-25 2002.

WARNING – EXPLOSION HAZARD. DO NOT DISCONNECT WHILE THE CIRCUIT IS LIVE OR UNLESS THE AREA IS FREE OF IGNITIBLE CONCENTRATIONS.

WARNING – EXPLOSION HAZARD - DO NOT SEPARATE SENSOR WHEN ENERGIZED.

AVERTISSEMENT - RISQUE D'EXPLOSION. NE PAS DECONNECTER LORSQUE LE CIRCUIT EST SOUS TENSION OU SI LA ZONE N'EST PAS EXEMPTÉ DE CONCENTRATIONS INFLAMMABLES.

AVERTISSEMENT - RISQUE D'EXPLOSION - NE PAS SÉPARER LE CAPTEUR LORSQU'IL EST SOUS TENSION.

9.2 Technical data, explosion - proof

For connection to intrinsically safe electric circuit and for the use in hazardous areas the CON 021 / 031 signal converter is tested and certified for:

Explosion protection class

cCSAus

'Intrinsically safe (Ex ia)'	
Identification:	Class I, Div 1,
	Group ABCD T4
	(Class 1, Zone 0/1)
	$U_i = 28V, I_i = 140mA, P_i = 1W$
	$C_i = 6,5nF, L_i = 3\mu H + 25\mu H$
	T4: -20°C ... +80°C
	Control Dwg CDG_9200-00006n (Figure 9-2)
Standards:	CAN/CSA-C22.2 No. 0-M91 General Requirements - Canadian Electrical Code, Part II
	CSA C22.2 No.60079-0-19 Explosive Atmospheres – Part 0 : Equipment – General requirements
	CSA C22.2 No. 60079-11-14 (R2018) Explosive Atmospheres – Part 11 : Equipment – Protection by intrinsic safety “i”
	UL 60079-0-2019 Explosive Atmospheres – Part 0 : Equipment – General requirements
	UL 60079-11-2018 Explosive Atmospheres – Part 11 : Equipment – Protection by intrinsic safety “i”
	CAN/CSA-C22.2 No. 25-17 Enclosures for Use in Class II, Division 1, Groups E, F, and G Hazardous Locations
	CSA C22.2 No. 61010-1-04 Safety requirements for Electrical equipment for Measurement control, and Laboratory Use - Part 1:General requirements
	UL 61010-1 Electrical Equipment For Measurement, Control, and Laboratory Use; Part 1: General Requirements
'non – incentive (Ex nA)'	

10.2 Influence of safety barriers on the sensor signal

The use of safety barriers of type Stahl 9001/00-280-085-101 for the supply circuit and 9001/00-280-020-101 for the measuring circuit results in the following influence on the maximum output voltage at converter supply voltage of -26V:

CON 021 or CON 031: maximum output voltage approximately -17.0 V

CON 021/91x-xxx or CON 031/91x-xxx: maximum output voltage approximately -15.5 V

In case of longer cables between safety barriers and measuring amplifiers, the upper cut-off frequency might be reduced by the series resistor of the barrier (1510 Ω at barrier 9001/00-280-020-101) and the cable capacity:

-3dB at $f = 2$ kHz and $C_L = 50$ nF, corresponding to 330 m cable length with 150 nF/km

-1dB at $f = 2$ kHz and $C_L = 25$ nF, corresponding to 165 m cable length with 150nF/km