



Safety Manager Release 162



Hardware Reference

EP-SM.MAN.6284

Issue 2.1 | December 2023

- Original Instructions -

15.5 IOTA-R24

15.5.1 Redundant IO Termination Assembly

The IOTA-R24 assembly enables the use of a redundant set of RUSIO-3224 or RUSLS-3224 modules. For physical and schematic representations of the IOTA-R24 see Figure 1 and Figure 2.

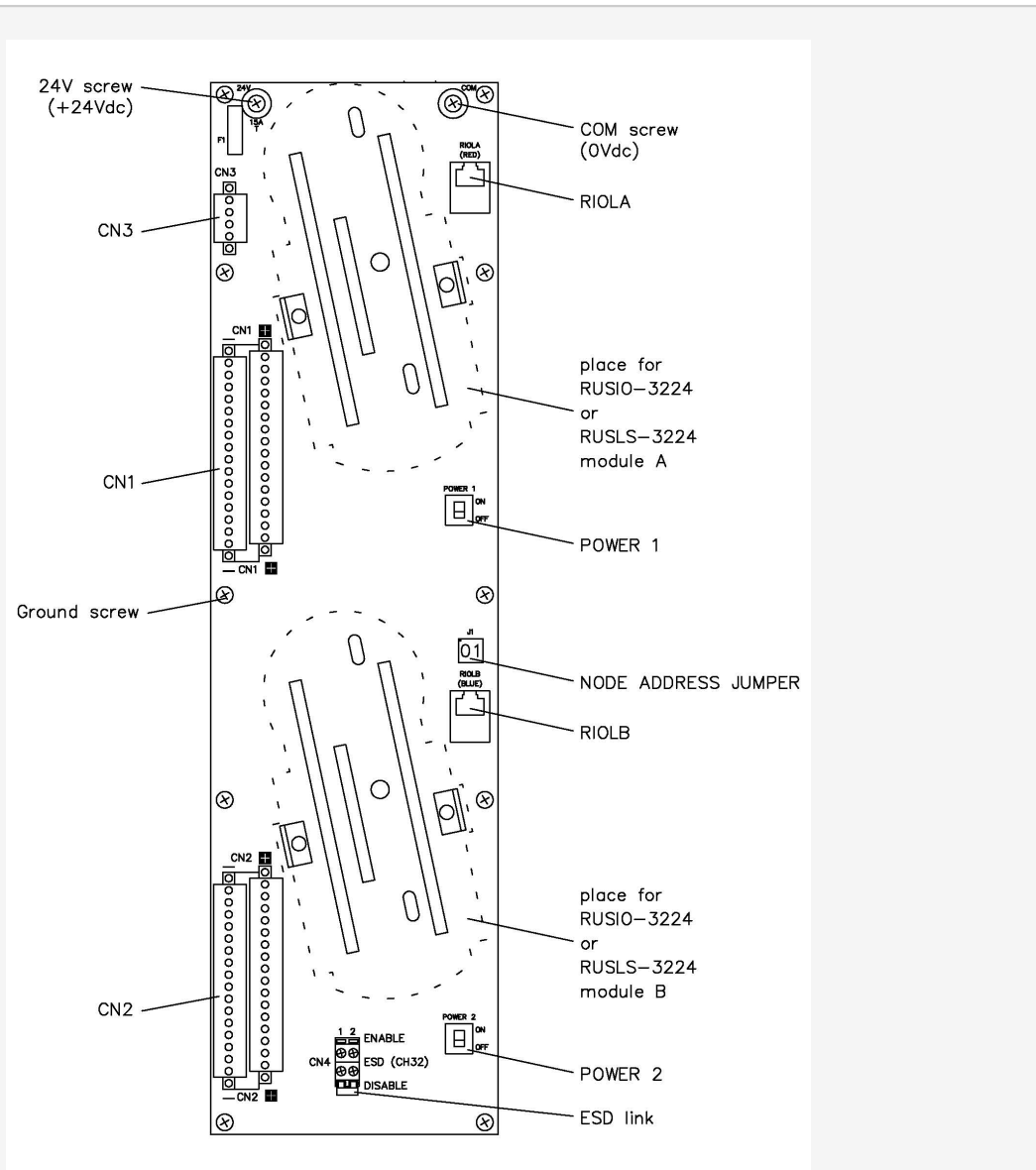

Figure 15-17: Mechanical layout

15 Field Termination Assembly Module

15.5 IOTA-R24

The IOTA-R24 can be used in applications up to SIL 3, in compliance with IEC 61508/61511.

The IOTA-R24 provides for:

- Connectors for two (redundant) RUSIO-3224 or RUSLS-3224 modules
- 32 (universal) IO channel connections (CN1 and CN2)
- 4 (identical) V+ connections (CN3), for active AI devices
- Two RJ45 connectors for 100MB Ethernet communication (RIOLA and RIOLB)
- 24V power connection (24V screw and COM screw to the carrier power rails)

The RUSIO-3224 or RUSLS-3224 modules are placed on the indicated positions of the IOTA-R24. See for Figure 1 details.

The RUSIO-3224 or RUSLS-3224 module in the top position is addressed as module 'A', the bottom one as module 'B'.

The IOTA-R24 module has two switches:

- Use POWER 1 to switch Module 'A' on and off
- Use POWER 2 to switch Module 'B' on and off

The node number of the IOTA-R24 is set by placing the proper node address jumper on the IOTA-R24 assembly.

The Emergency ShutDown (ESD) function can be enabled or disabled with the ESD (CH32) link.

The IO field signals are connected on CN1 and CN2; see Figure 1. The minus-row of CN1 and CN2 (left side) are all connected with 0V. The plus-row of CN1 and CN2 (right side) are the 'real' channels. Any type of IO field signal has only to be connected to the two connections of the applicable universal channel.

CN3 is used to connect active AI devices.

The IOTA-R24 module has two connectors to link the RUSIO-3224 or RUSLS-3224 modules with the Safety Manager Controller:

- The RIOLA connector is used for module 'A'
- The RIOLB connector is used for module 'B'

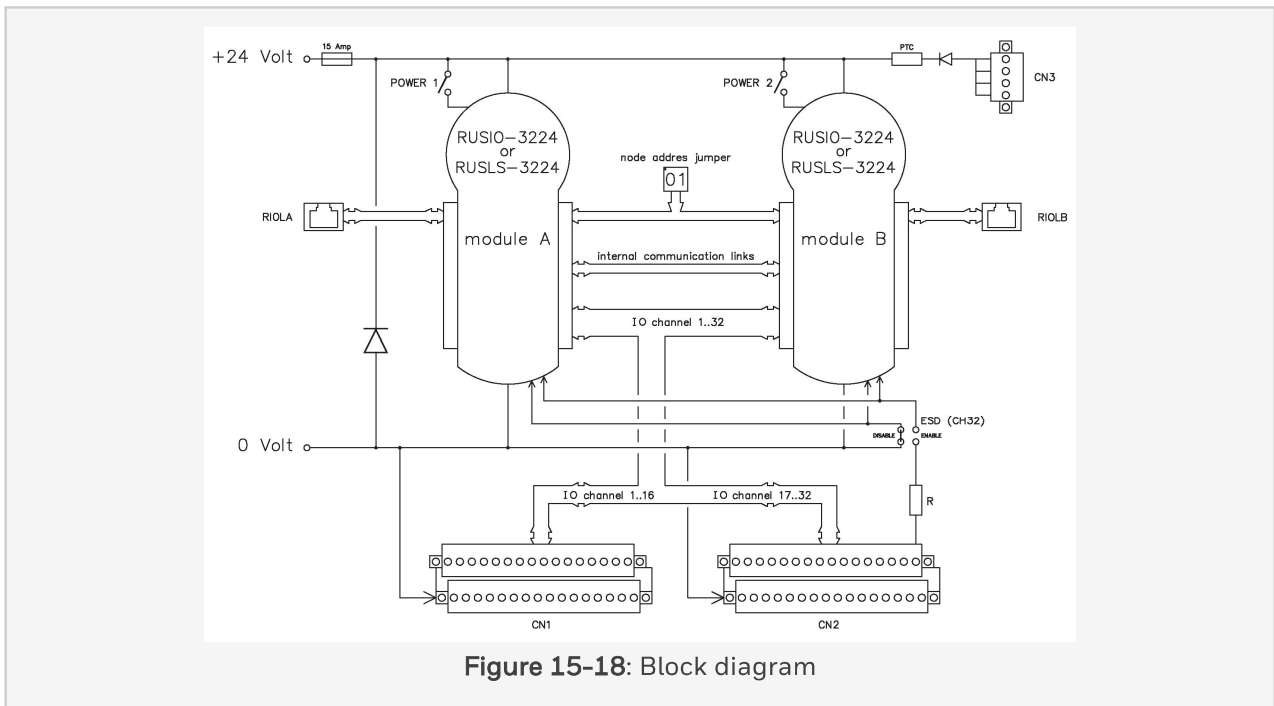

15.5.2 Mounting

The IOTA-R24 is mounted on a (metal) carrier (18 inch or 36 inch long). For details see:

- MCAR-01
- MCAR-02

The carrier provides the ground rail and the (+24V and 0V) power rails.

15.5.3 Connections

15.5.3.1 Channel 1 thru 16 on CN1

IO-channel 1 thru 16 are terminated on CN1.

Detail A shows the top and side view (field-connectors placed).

Detail B shows the second side-view with the field-connectors placed.

Detail C shows the second side-view with the field-connectors removed.

15 Field Termination Assembly Module

15.5 IOTA-R24

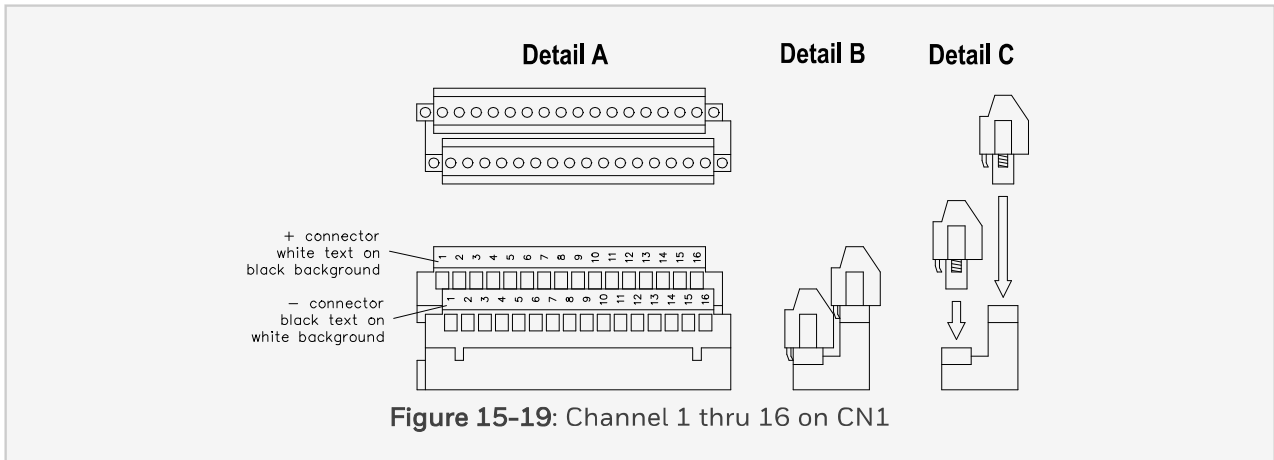

15.5.3.2 Channel 17 thru 32 on CN2

IO-channel 17 thru 32 are terminated on CN2.

Detail A shows the top and side view (field-connectors placed).

Detail B shows the second side-view with the field-connectors placed.

Detail C shows the second side-view with the field-connectors removed.

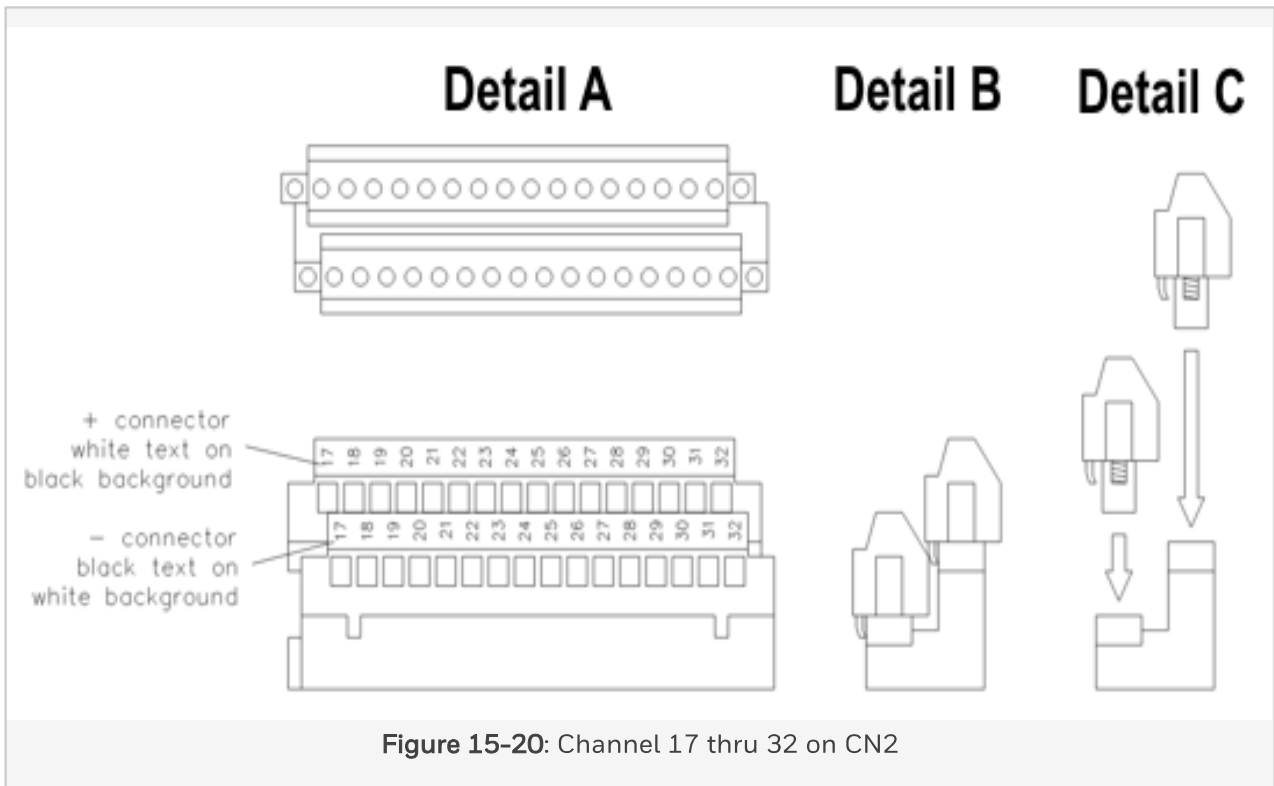

15.5.3.3 V+ connections on CN3

CN3 has four (uni-directional) V+ connections for field signals that require a passive analog input. For details about this type of channel configuration see RUSIO-3224 or RUSLS-3224.

Detail A shows the top and side view (field-connectors placed).

Detail B shows the second side-view with the field-connector placed.

Detail C shows the second side-view with the field-connector removed.

15 Field Termination Assembly Module

15.5 IOTA-R24

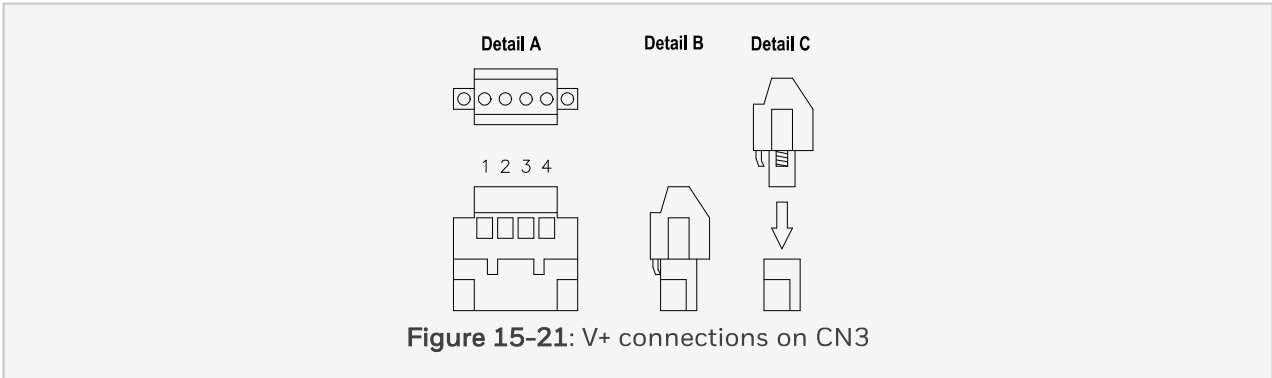

15.5.3.4 Ethernet connectors

The ethernet connectors (RIOLA and RIOLB) are shielded RJ-45 connectors.

The pin assignment of the RJ-45 connectors is shown below.

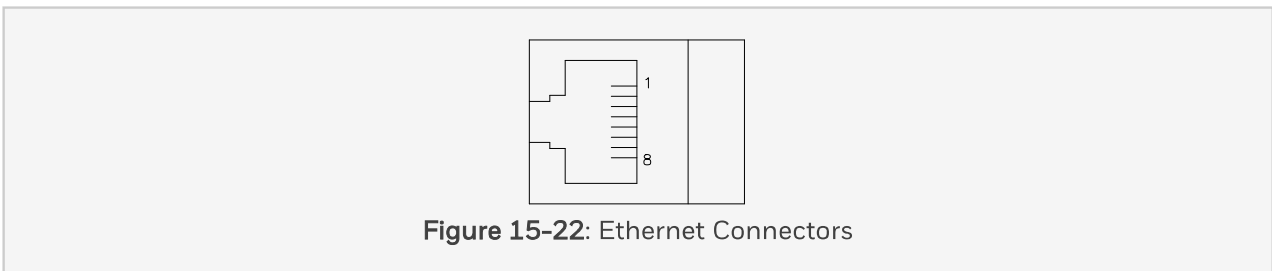

Contact	Signal	Direction	Description
1	TD+	Out	Transmitted data
2	TD-	Out	Transmitted data
3	RD+	In	Received data
4	-		
5	-		
6	RD-	In	Received data
7	-		
8	-		
Case	Shield		HF-connection to earth

15.5.3.5 ESD enable / disable link

The ESD function (on channel 32) can be enabled (or disabled) with a link on the IOTA.

In case the link is placed in the drawn position (See the below figure), channel 32 can be used as universal channel (analog or digital; input or output).

In case the link is in the ENABLE position, channel 32 must be used as ESD input.

A (normally closed) ESD switch (with 1 kOhm series resistor) must be connected between CH32+ and CH32- of the IOTA.

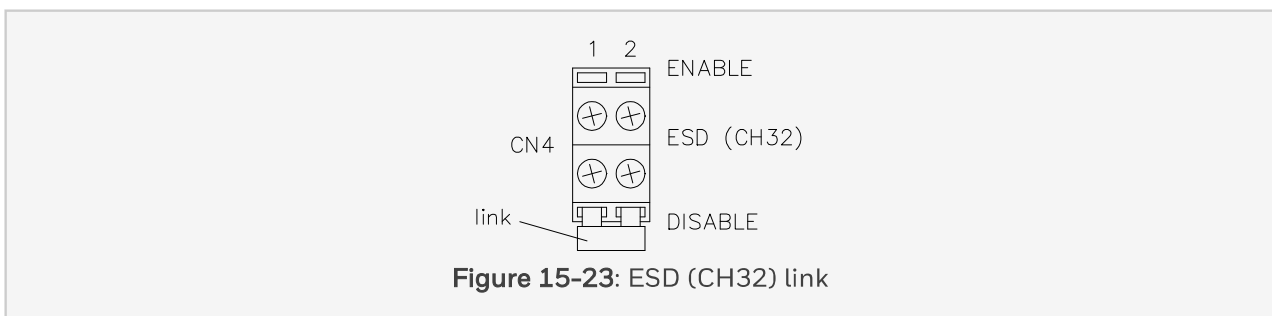

Figure 15-23: ESD (CH32) link

15 Field Termination Assembly Module

15.5 IOTA-R24

15.5.4 Node address jumpers

The node address jumper is used to give the processors in the RUSIO-3224 or RUSLS-3224 module(s) the node address of the IOTA.

The jumper is a 10.2 x 10.2 x 6.1 mm (0.4 x 0.4 x 0.24 in) gray plastic jumper set; it has a (two digit) number that is clearly visible.

For an example of a node address jumper see the below figure.

The jumpers are available in kits of ten numbers:

- 51153818-201 is a kit with the numbers 01 thru 10.
- 51153818-202 is a kit with the numbers 11 thru 20.
- 51153818-203 is a kit with the numbers 21 thru 30.
- 51153818-204 is a kit with the numbers 31 thru 40.



Figure 15-24: Node address jumper - front and side view

15.5.5 RUSIO-3224/RUSLS-3224 connections

The IOTA-R24 assembly supports all IO types that can be configured in the RUSIO-3224 or RUSLS-3224 module.

The supported IO types are:

- Line monitored digital input
- Non line monitored digital input
- Line monitored ESD input (on Channel 32)
- Analog input 0-20mA or 4-20mA
- Digital output (0.5 A), with or without configurable line monitoring

- Multiple digital output (1 A or 2 A), with or without line monitoring
- Analog output 0-20mA or 4-20mA

Further details on the connection and specifications of these IO types is described elsewhere. See RUSIO-3224 or RUSLS-3224.

The below figure shows the IO connection diagram of the IOTA-R24 .

The two RUSIO-3224 or RUSLS-3224 modules are connected in parallel. Each one is capable of controlling the IO.

15 Field Termination Assembly Module

15.5 IOTA-R24

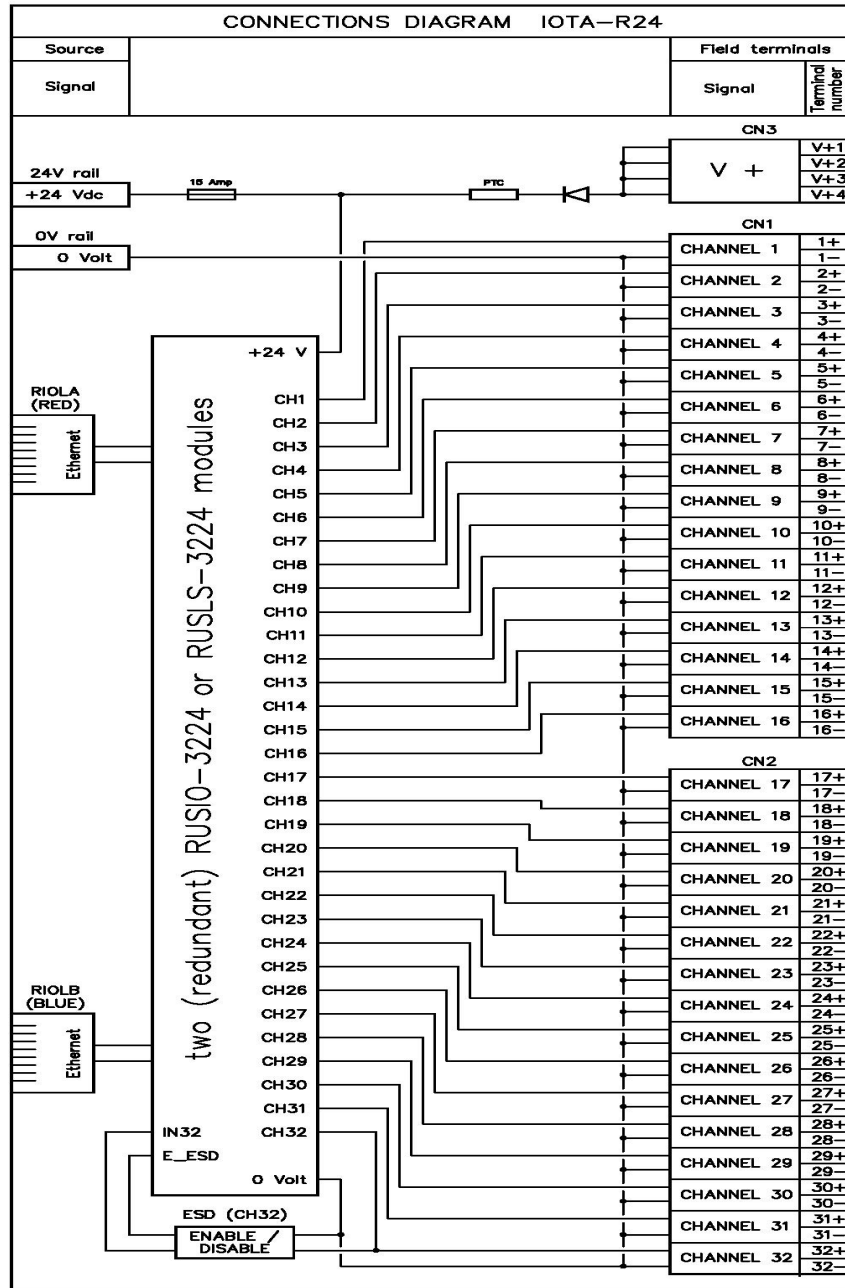

Figure 15-25: Connection diagram

15.5.6 Technical data

The IOTA-R24 assembly has the following specifications:

15 Field Termination Assembly Module

15.5 IOTA-R24

General	Type number:	FC-IOTA-R24
	Operating temperature:	-40 .. +70°C (-40 .. +158°F)
	Storage temperature:	-40 .. +85°C (-40 .. +185°F)
	Relative humidity:	10..95% (non condensing)
	Pollution:	Pollution degree 2 or better
	Approvals:	CE, UL, TUV
Power	Supply voltage:	24 V DC -15%..+30%
	Supply load:	max. 10 A
	Reverse polarity protection:	parallel diode (blows the fuse)
	V+ pins:	
	• Max. current:	1 A (total of four CN3 pins)
	• Max. voltage drop:	<1.5V (at 0.7A)
	• Max. reverse voltage:	36V
Fuse	Fuse rating:	15 A
	Fuse dimensions:	Blade 5x19 mm
	Voltage rating AC:	-
	Voltage rating DC:	32 V
	Manufacturer:	Littelfuse
	Manufacturer PN:	0287015.PXS

Connections	24V supply:	2 x M4 (to power rail of the carrier)
	Ground:	10 x M3.5 (to metal of the carrier)
	Ethernet:	RJ-45
	IO (CN1 and CN2):	Weidmuller: BLZ 5.08/16/90F SN SW
	V+ (CN3):	Weidmuller: BLZ 5.08/4/90F SN SW
	Screw terminals (CN1,CN2,CN3):	
	• Max. wire size:	0.50 .. 2.50 mm ²
	• Strip length:	7 mm
	• Tightening torque	0.5 Nm (0.37 ft-lb)
Physical Data	Dimensions (H x W x D):	64 x 120.7 x 443.2 mm 2.52 x 4.75 x 17.45 in
	Weight:	0.57 kg 1.26 lbs