

Safety Manager
Hardware Reference

EP-SM.MAN.6284

Issue 1.0

20 February 2013

Release 151

Field Termination Assembly modules

15

This chapter describes the field termination assembly modules that are available for Safety Manager.

The following Field Termination Assembly (FTA) modules are described:

FTA		see
Input FTAs		
TSDI-1624	Safe digital input FTA (24 Vdc, 16 channels)	page 505
TSDI-1648	Safe digital input FTA (48 Vdc, 16 channels)	page 509
TSDI-16UNI	Safe digital input FTA (24/48 Vdc, NAMUR, 16 channels)	page 513
TSDI-1624C	Safe current-limited digital input FTA (24 Vdc, 16 channels)	page 516
TSDI-16115	Safe active/passive digital input FTA (115 Vac/dc, 16 channels)	page 519
TIDI-1624	Non-safe Isolated passive digital input FTA (16 channels)	page 528
TSAI-0410	Safe analog input FTA (4 channels)	page 532
TSAI-1620m	Safe 0-20 mA and 4-20 mA analog input FTA (16 channels)	page 535
TSHART-1620m	Safe 0-20 mA and 4-20 mA analog input FTA with HART interface (16 channels)	page 543
TSGAS-1624	Safe gas / flame detector input FTA (0-20 mA, 16 channels)	page 552
TSGASH-1624	Safe gas/flame detector input FTA with HART interface (0-20 mA, 16 channels)	page 557
TSGASH-1624P	Safe gas/flame detector input FTA with HART interface (0-20 mA, 16 channels)	page 563
TSFIRE-1624	Safe fire detector input FTA with line monitoring (24 Vdc, 16 channels)	page 569
Output FTAs		
TSDO-0824	Safe digital output FTA (24 Vdc, 8 channels)	page 575
TSDO-0824C	Conformal coated safe digital output FTA, current limited (24 Vdc, 8 channels)	page 578
TDOL-0724	Line-monitored relay contact digital output (7 channels, 24Vdc)	page 582

Specific FTAs can only be used with particular IO or IO converter modules. Table 72 on page 502 shows possible FTA - IO module combinations and Table 73 on page 503 shows possible FTA-CP module combinations.

Table 72 possible FTA - IO module combinations

FTA module	Input module	Output module	Remarks
TSDI-1624	SDI-1624		
TSDI-1648	SDI-1648		
TSDI-16UNI	SDIL-1608 SDI-1624 SDI-1648		
TSDI-1624C	SDI-1624		
TSDI-16115	SDI-1624		
TIDI-1624	SDI-1624		
TSAI-0410	SAI-0410		
TSAI-1620m	SAI-1620m		
TSHART-1620m	SAI-1620m		with HART connection
TSGAS-1624	SAI-1620m		
TSGASH-1624	SAI-1620m		with HART connection
TSGASH-1624P	SAI-1620m		with HART connection
TSFIRE-1624	SAI-1620m		
TSDO-0824		SDO-0824	
TSDO-0824C		SDO-0824	
TDOL-0724	SDI-1624	SDO-0824	both modules are required
TDOL-0724P	SDI-1624	SDO-0824	both modules are required

TSDO-0824

Safe digital output FTA (24 Vdc, 8 channels)

Description

Field termination assembly module TSDO-0824 is the interface between system interconnection cable SICC-0001/Lx and the external field wiring (screw terminals). The eight channels of a (redundant pair of) SDO-0824 module(s) can be connected to the TSDO-0824 module via the system interconnection cable SICC-0001/Lx.

The FTA module has a universal snap-in provision for standard DIN EN rails, and screw terminals for connecting field wiring.

Figure 345 Mechanical layout

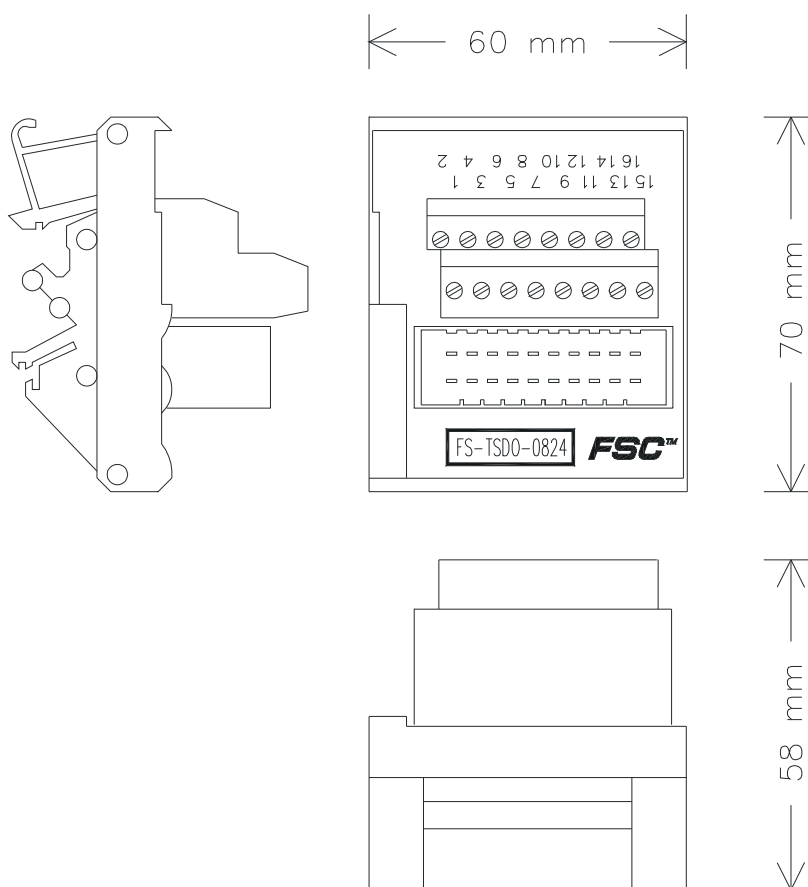

Applications

For details on applications and connection options for the TSDO-0824 module, see section “SICC-0001/Lx” on page 715.

Connections

The connections diagram of the TSDO-0824 module:

Figure 346 Connections diagram

CONNECTIONS DIAGRAM FS-TSDO-0824			
SIC connector		Field terminals	
Pin number	Signal	Signal	Terminal number
A10	nc		
B10	nc		
A9	OUT1+	OUT1+	1
B9	OUT1-	OUT1- (0 Volt)	2
A8	OUT2+	OUT2+	3
B8	OUT2-	OUT2- (0 Volt)	4
A7	OUT3+	OUT3+	5
B7	OUT3-	OUT3- (0 Volt)	6
A6	OUT4+	OUT4+	7
B6	OUT4-	OUT4- (0 Volt)	8
A5	OUT5+	OUT5+	9
B5	OUT5-	OUT5- (0 Volt)	10
A4	OUT6+	OUT6+	11
B4	OUT6-	OUT6- (0 Volt)	12
A3	OUT7+	OUT7+	13
B3	OUT7-	OUT7- (0 Volt)	14
A2	OUT8+	OUT8+	15
B2	OUT8-	OUT8- (0 Volt)	16
A1	nc		
B1	nc		

Technical data

The TSDO-0824 module has the following specifications:

General	Type numbers ¹ :	FS-TSDO-0824
		FC-TSDO-0824
	Approvals:	CE, TUV, UL, CSA, FM
Power	Number of channels:	8
	Maximum voltage:	36 Vdc – IEC 1010 (1990), overvoltage category 3 (Table D.12)
	Maximum continuous current per channel:	1.5 A
	Actual maximum current defined by connected output module	
Physical	Module dimensions:	60 × 70 × 58 mm (L × W × H) 2.36 × 2.76 × 2.28 in (L × W × H)
	DIN EN rails:	TS32 / TS35 × 7.5
	Used rail length:	61 mm (2.40 in)
Termination	Screw terminals:	
	• Max. wire diameter	2.5 mm ² (AWG 14)
	• Strip length	7 mm (0.28 in)
	• Tightening torque	0.5 Nm (0.37 ft-lb)

¹ FS-type modules are non conformal coated modules.
FC-type modules are conformal coated modules. Conformal coated modules have the letters “CC” preceding the version number.

TSDO-0824C

Conformal coated safe digital output FTA, current limited (24 Vdc, 8 channels)

Description

Field termination assembly module TSDO-0824C is the interface between safe digital output module SDO-0824 with a system interconnection cable (SICC-0001/Lx) and the external field wiring (screw terminals). It can be used for interfacing to Class I, Division 2 Hazardous locations.

The TSDO-0824C provides eight current limited safe digital outputs to the field. Each output is capable of supplying 110 mA (= 2.5 Watt at 24 Vdc).

The FTA module is coated conform the requirements for type A coatings given in IEC 60664-3 (the values for POLLUTION DEGREE 1 apply), has a universal snap-in provision for standard DIN EN rails, and screw terminals for the field wiring.

Figure 347 Mechanical layout

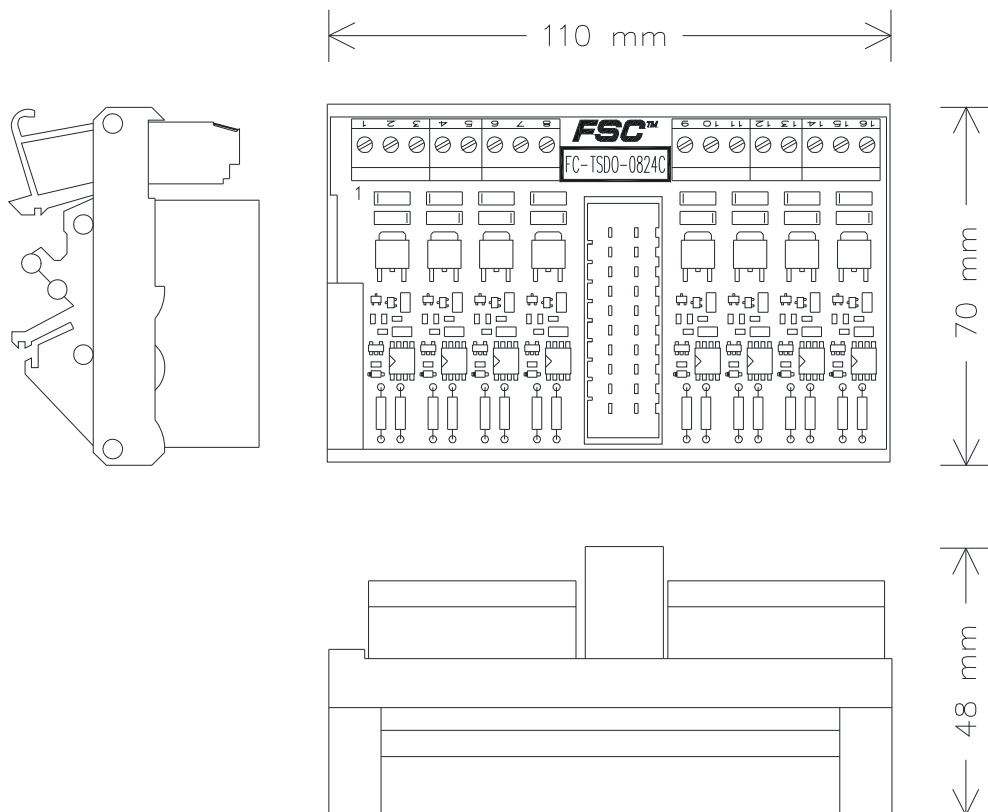

Applications

For details on applications and connection options for the TSDO-0824C module, see section “SICC-0001/Lx” on page 715.

Figure 348 Schematic diagram

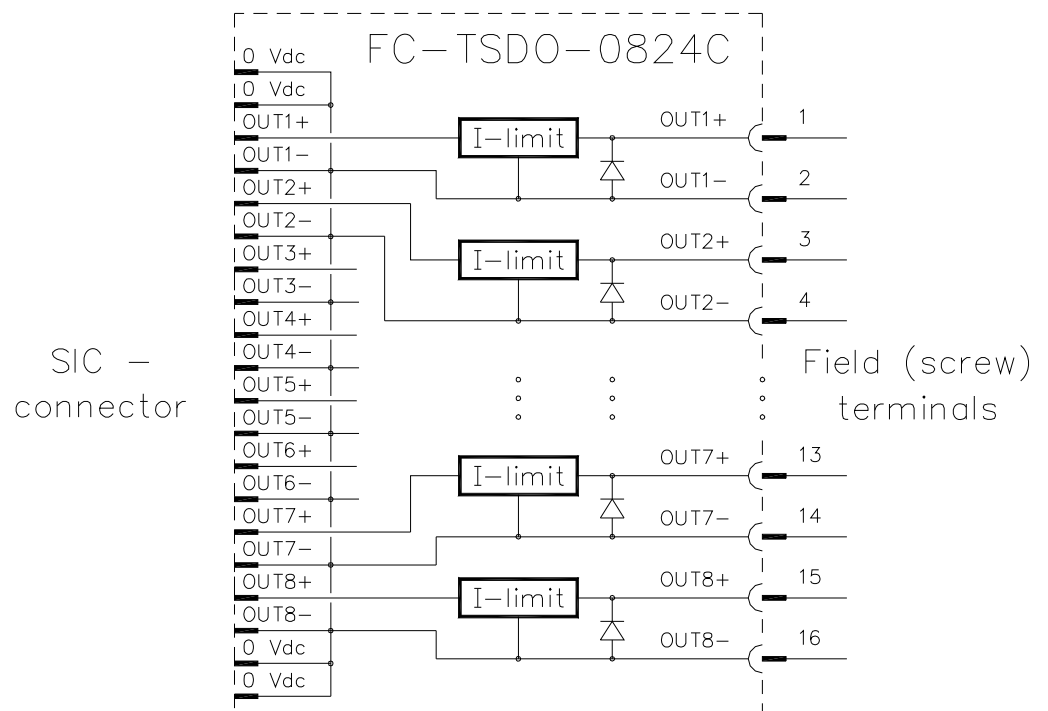

Main function

The TSDO-0824C can energize loads (for example solenoids or LEDs) with voltage-current limitation in compliance with Hazardous Class I, Division 2. The external output-signal (OUT+) is electronically current-limited.

Connections

The connections diagram of the TSDO-0824C:

Figure 349 Connections diagram

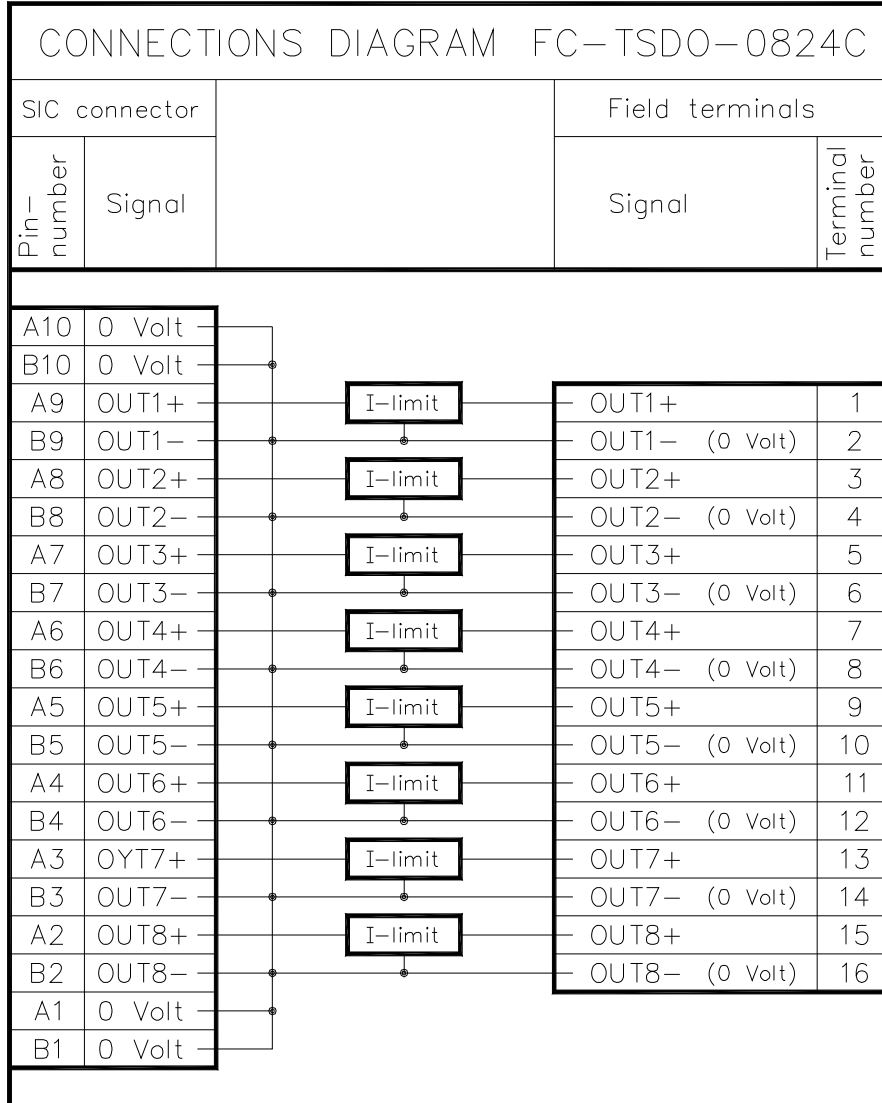

Technical data

The TSDO-0824C has the following specifications:

General	Type number ¹ :	FC-TSDO-0824C
	Approvals	CE, TUV, UL, CSA, FM
	Environmental shielding	Conformal coating
Power	Number of channels:	8
	Maximum voltage:	36 Vdc – IEC 1010 (1990), overvoltage category 3 (Table D.12)
	Power requirements:	5 mA per channel (plus output load)
Output	Output current limit:	> 110 mA
	Max. output load:	2.5 Watt (at 24 Vdc)
	Voltage drop:	< 1.5 Vdc at 110 mA
	Off current:	< 0.1 mA
Physical	Module dimensions:	110 × 70 × 48 mm (L × W × H) 4.32 × 2.76 × 1.89 in (L × W × H)
	DIN EN rails:	TS32 / TS35 × 7.5
	Used rail length:	111 mm (4.36 in)
Termination	Screw terminals:	
	• Max. wire diameter	2.5 mm ² (AWG 14)
	• Strip length	7 mm (0.28 in)
	• Tightening torque	0.5 Nm (0.37 ft-lb)
Field signal specifications	HYDROGEN (Group A & B)	
	• Max. loop inductance	3.0 mH
	• Max. loop capacitance	0.2 μF
	NON-HYDROGEN (Group C & D)	
	• Max. loop inductance	12 mH
	• Max. loop capacitance	5 μF

1 FC-type modules are conformal coated modules.

Relay contact	Max switched power:	150 Watts
	Expected life:	<ul style="list-style-type: none"> • electrical • mechanical 100,000 switch operations 30,000,000 switch operations
Power consumption	Field power	
	24Vdc:	< 9mA (all channels off)
	24 Vdc (consumed via SDO-0824 and SDI-1624 IO)	
	Relais + channel 8:	approx. 200mA (out of TSDO-0824) max. 250mA at V_{max}
	Read back circuit:	< 110mA (single SDI-1624) or < 210mA (redundant SDI-1624) max. 275mA at V_{max}
Physical	Module dimensions:	240 x 109 x 80 mm (L x W x H) 9.45 x 4.29 x 3.15 in (L x W x H)
	DIN EN rails:	TS32 / TS35 × 7.5
	Used rail length:	241mm (9.49 inch)
Termination	Channel screw terminals:	<ul style="list-style-type: none"> • max wire diameter • strip length • tightening torque 2.5 mm ² (AWG 14) 7 mm (0.28 in) 0.5 Nm (0.37 ft-lb)
	Power connector	2 pole header with keying
	• make and type:	Weidmuller: BVZ 7.62HP/02/180F SN (conn.)
	• strip length:	Weidmuller: BV/SV7.62HP KO (keys)
	• Connectable conductors:	8 mm (0.28 in) 0.5-6mm ² (AWG 20-AWG 10)

1 FC-type modules are conformal coated modules.

Technical data

The TDOL-07120 module has the following specifications:

General	Type numbers ^{1 2} :	FS-TDOL-07120 V1.1	
		FC-TDOL-07120 CCV1.1	
	Approvals:	CE, UL, CSA; TUV pending	
Outputs	Number of channels:	7	
	Max. output current:	2 Amp (at 120Vac) ³ 0.28 Amp at 120Vdc (UL limit) 0.5 Amp at 120Vdc (relay limit)	
	Output load 120Vdc:	resistive or inductive with spark suppression diode	
	Channel fuses:	5 x 20 mm (0.20 x 0.79 in) 2 Amp (slow-acting)	
	Output supply voltage:	120VAc or 120Vdc +/- 20%	
	Minimum required field load:	1 Watt	
	Leakage current to load:	max. 1mA at 120V	
	No load output voltage:	<ul style="list-style-type: none"> • output OFF • output ON 	35..130 Vdc with AC output supply or 90% of DC output supply voltage 100% of output supply voltage (AC or DC)
	Short-circuit detection load threshold:	$200\Omega < R_{Th} < 400\Omega$	
	Max. load capacitance:	1uF	
Relay contact	Max switched power:	1250 VA / 60 Watts	
	Expected life:	<ul style="list-style-type: none"> • electrical • mechanical 	100,000 switch operations 30,000,000 switch operations
Power consumption	Field power		
	120Vac/Vdc:	< 8mA (all channels off)	
	24 Vdc (consumed via SDO-0824 and SDI-1624 IO)		
	Relays + channel 8:	approx. 200mA (out of TSDO-0824) max. 250mA at V_{max}	
	Read back circuit:	< 110mA (single SDI-1624) or < 210mA (redundant SDI-1624) max. 275mA at V_{max}	