

## Features and Benefits

- **Versatile:** Supplies operating voltages to both Harmony block and rack equipment.
- **Availability:** Selectable N, N+1, N+x, and 2N power supply redundancy.
- **High output capacity:** 260 watts output per module means fewer power modules are needed.
- **Active load sharing:** Insures all power modules share load equally.
- **Inputs:** 120/240 VAC or 125 VDC with mixed AC and DC inputs in 2N redundancy.
- **Input power factor correction:** Lowers upstream investments such as electrical distribution and uninterrupted power supply (UPS).
- **Power monitoring:** Monitors AC and DC power inputs, system I/O and bus voltages, cabinet temperatures, and auxiliary channel and contact inputs.
- **On-line replaceable:** Power supply modules and fans are replaceable while the system is operating.



TC00894A

The power architecture of the Harmony Modular Power System II is designed to be flexible so that it can be easily adapted to the needs of the application.

When two power sources are utilized the Modular Power System II can be split into two sections with four power module slots per section. This *2N split architecture* offers the highest level of power availability. Each section supplies only 50 percent of the load under normal conditions but is capable of supplying 100 percent of the load under a failure condition. The low stress at 50 percent of capacity assures a long life time.

When only one power source is used to supply *secure* power to the Modular Power System II, the two sections of the split architecture are strapped together providing *N+x power architecture*. Each power module is supplied from one source and shares the load equally.

## Overview

The Modular Power System II supplies 5 VDC, 15 VDC, -15 VDC, 24 VDC, 48 VDC, and 125 VDC power to Harmony components of the Symphony™ Enterprise Management and Control System. Figure 1 shows the power system architecture. The power system provides the operating voltages for Harmony devices such as Harmony I/O blocks, and Harmony rack I/O, rack controller, and rack communications modules. It also provides power to operate field devices.

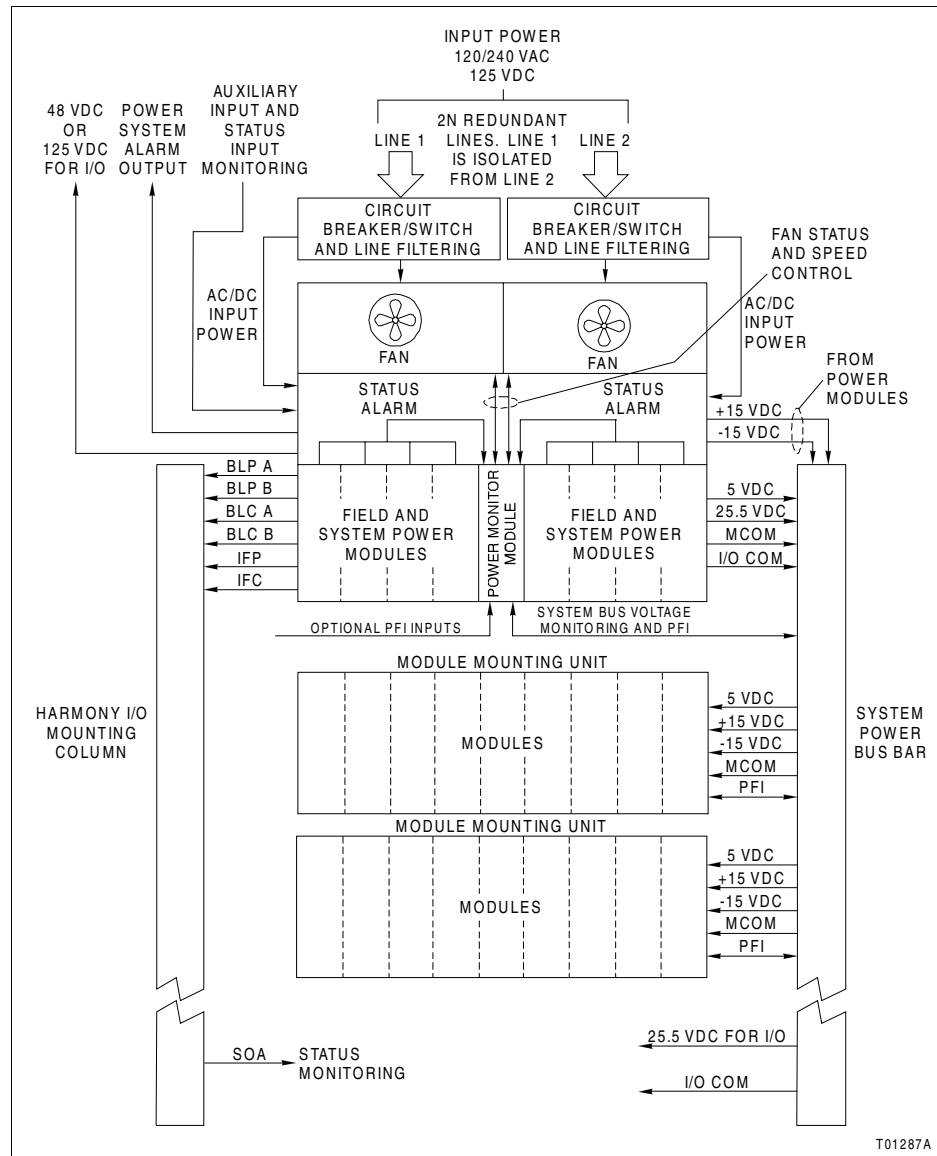

Figure 1. Modular Power System II Functional Diagram

The Modular Power System II consists of a power module chassis, fan chassis, power entry circuit breakers or switches, system fans, power monitor module, and power modules: System, Harmony, and field.

### I/O Block Operating Voltages

At the left side of Figure 1, the BLP A (block logic power) and BLP B lines shown entering the Harmony I/O mounting column are redundant 24 VDC outputs that provide the operating voltage

for I/O blocks and Hnet repeaters. The IFP (internal field power) line shown entering the mounting column is 24 VDC I/O power for field devices. Additionally, the power system provides 48 VDC and 125 VDC field power.

## Rack I/O Module Operating Voltages

At the right side of Figure 1, the 5 VDC, 15 VDC, and -15 VDC lines shown entering the system power bus bar are the operating voltages for rack I/O devices. The 24 VDC (25.5 VDC actual voltage) line shown entering the system power bus bar is I/O power for field devices. Additionally, the power system provides 48 VDC and 125 VDC field power.

## System Power Module

---

The IPSYS01 System Power module is a rack mounted circuit board that supplies 5 VDC, 15 VDC, and -15 VDC system operating voltages to rack I/O devices and 24 VDC field I/O power to a cabinet. The system power module can accept 120 VAC, 240 VAC, or 125 VDC input power.

The AC inputs have active power factor correction to greater than 0.95. Current sharing circuitry enables the system power modules to equally share output current. The module monitors the DC-to-DC converters and power factor corrector and displays the status on five red/green faceplate LEDs. The system power module mounts in one power module chassis mounting slot.

## Field Power Modules

---

The IPFLD01 and IPFLD24 Field Power modules are similar to the system power module except that they output 24 VDC field I/O power only. The difference between the two power modules is that the IPFLD24 power module provides twice the output power of an IPFLD01 power module. The IPFLD48 and IPFLD125 Field Power modules output 48 VDC and 125 VDC field I/O power respectively.

The field power modules have the same power factor correction and internal monitoring circuitry. There are only two red/green LEDs on the field power modules: One for the DC-to-DC converter status and one for the power factor corrector status. The field power module mounts in one power module chassis mounting slot.

## Harmony Power Module

---

The IPBLC01 Harmony Power module is similar to the IPFLD24 field power module except that it supplies 24 VDC operating voltage to power Harmony I/O system devices such as I/O blocks and Hnet repeaters. The Harmony power module mounts in one power module chassis mounting slot.

## Power Monitor Module

---

The IPMON01 Power Monitor module checks power system status and the status inputs, which include:

- All system bus voltages (5, 15, -15 VDC), Harmony bus voltages (24 VDC A and B), I/O bus voltages (24 VDC, 48 VDC, and 125 VDC).

- Two selectable auxiliary inputs to monitor 24 VDC, 48 VDC, or 125 VDC external sources.
- Two cabinet temperature monitor inputs.
- One power fail interrupt (PFI) alarm that can be configured for latching or nonlatching operation.
- Two logic level status inputs. These contact logic inputs can be selected to accept normally open or normally closed contact inputs.
- Three isolated outputs for bus alarm, power alarm, and I/O alarm.
- One power system status output for use on the Symphony Control Net (Cnet) communication network.
- Two fan status inputs.
- One power supply status signal from each power module.
- Power monitor module internal circuitry status.

The power monitor module mounts in the center power module chassis slot.

The power monitor module faceplate has three red/green LEDs to indicate power monitor module status and AC or DC input power line status. Eight additional LEDs are used to show the state of status inputs. There are six test points that accept a voltmeter probe for checking 5, 15, -15, and 24 VDC bus voltages (two test points are system common and I/O common). The power fail interrupt reset pushbutton is used to reset a PFI signal when the PFI latched option is enabled.

## Power Module Chassis

---

The Modular Power System II supports two different power module chassis: IPCHS01 and IPCHS02. The IPCHS01 chassis supports Harmony rack I/O power connection only. It cannot be used for Harmony I/O block power connection. The IPCHS02 chassis supports both Harmony I/O block connection and Harmony rack I/O connection.

### IPCHS01 Chassis

The IPCHS01 Power Module Chassis provides power input connection, power output bus bars, and various terminals for status inputs and outputs. It provides mounting for up to eight power modules and one power monitor module. There are nine mounting slots total. The center slot is dedicated to the power monitor module. Four slots on each side of the power monitor module hold power modules and have isolated power inputs.

All the power module outputs share the same bus. System power for the cabinet is made available at bus bars on the power module chassis backplane and at terminal strips (for  $\pm 15$  VDC and 48/125 VDC). Cables connect the bus bars and  $\pm 15$  VDC terminals to the system power bus bar for distribution to the cabinet. The 48/125 VDC terminals are user outputs.

Power modules and the power monitor module can be removed from the power module chassis and replaced while the system is on-line. Only IPSYS01, IPFLD01, IPFLD24, IPFLD48, and IPFLD125 power modules and the IPMON01 power monitor module can be mounted in this power module chassis. The IPFLD48 and the IPFLD125 power modules cannot coexist in the same power module chassis.

## IPCHS02 Chassis

The IPCHS02 Power Module Chassis is identical to the IPCHS01 chassis except that it has additional bus bars for Harmony power (24 VDC) and ground and a power distribution assembly circuit board that attaches to the bus bars. The power distribution assembly supports redundant power distribution to Harmony I/O system devices. This circuit board has connectors installed for attaching the Harmony I/O power cables.

Power modules and the power monitor module can be removed from the power module chassis and replaced while the system is on-line. The IPSYS01, IPFLD01, IPFLD24, IPFLD48, and IPFLD125 power modules, the IPMON01 power monitor module, and additionally the IPBLC01 Harmony Power module can be mounted in this power module chassis. The IPFLD48 and the IPFLD125 power modules cannot coexist in the same power module chassis.

## Power Entry Circuit Breaker or Switch

The IPECB11 or IPECB13 Power Entry Circuit Breaker and IPESW11 or IPESW13 Power Entry Switch terminate the AC or DC power input lines and provide line filtering before feeding power to the power module chassis backplane. These devices mount on the back of the power fan chassis. One circuit breaker or switch is used on N, N+1, and N+x redundant systems (Fig. 2); two are used on 2N redundant systems (Fig. 3). The isolated inputs on 2N redundant systems allow for mixed power inputs (i.e., 125 VDC and 120/240 VAC) because two separate power entry circuit breakers or switches feed isolated power inputs to the power module chassis.

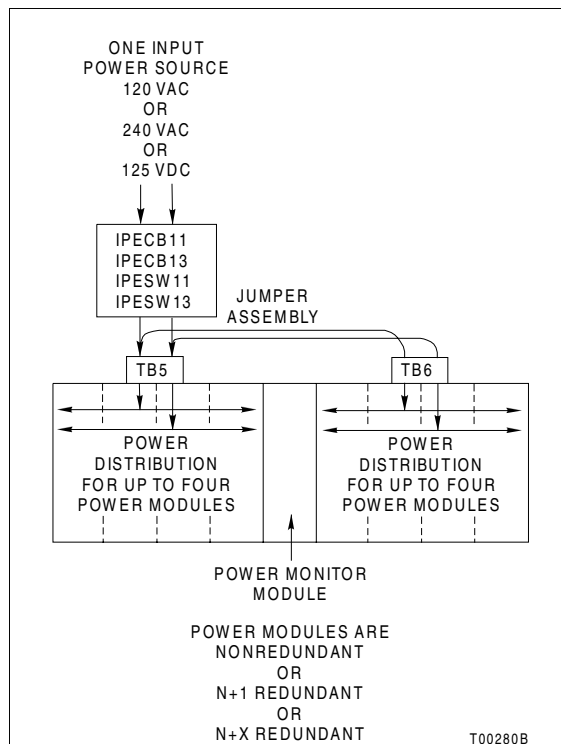

Figure 2. Input Power for N, N+1, and N+x Redundant Systems