

E96-440

Bailey®
infi 90

Instruction

Analog Input Termination Unit (NTAI06)

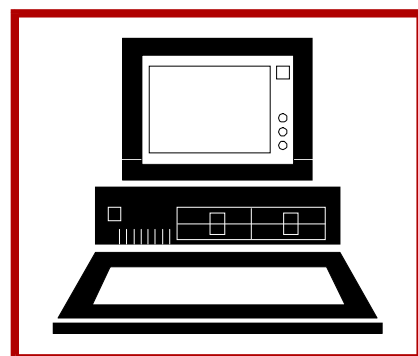
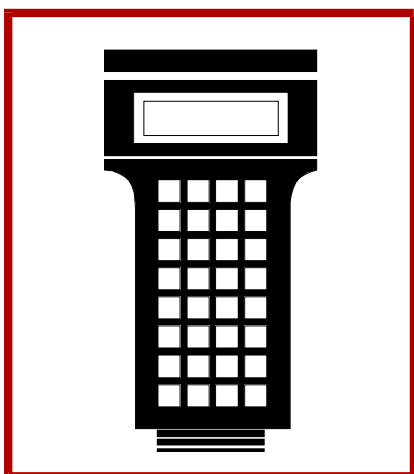
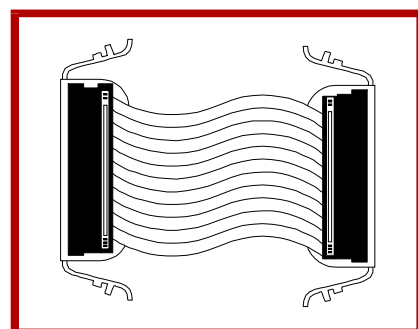
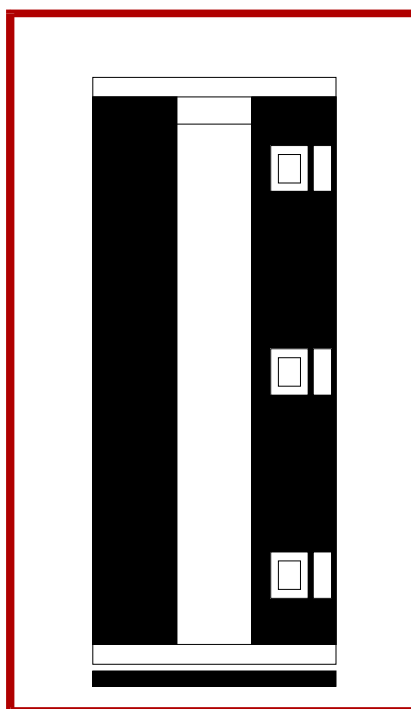
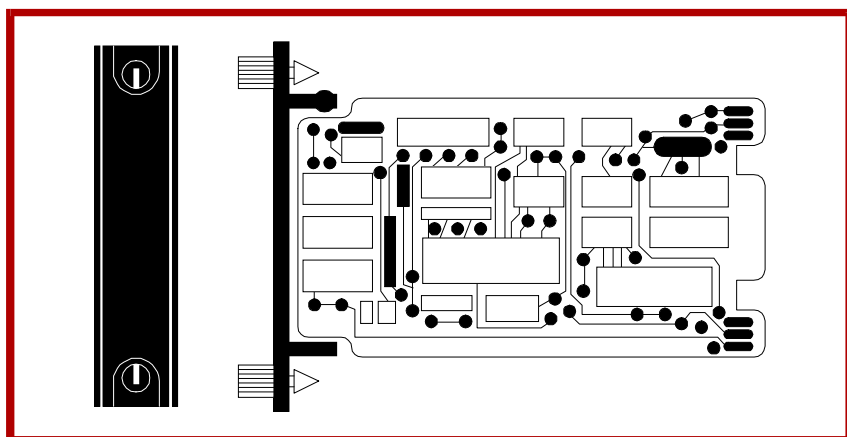
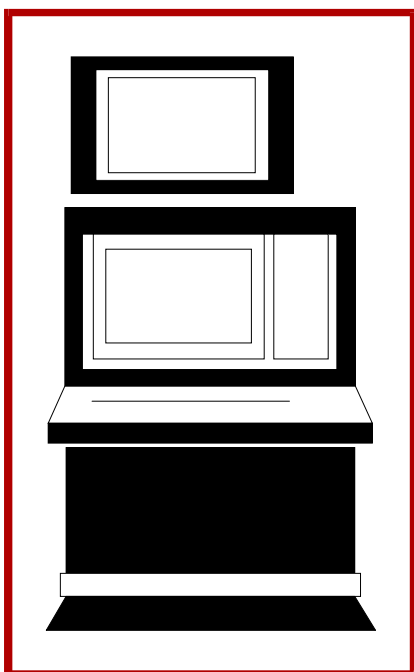

WARNING notices as used in this instruction apply to hazards or unsafe practices that could result in personal injury or death.

CAUTION notices apply to hazards or unsafe practices that could result in property damage.

NOTES highlight procedures and contain information that assists the operator in understanding the information contained in this instruction.

WARNING

INSTRUCTION MANUALS

DO NOT INSTALL, MAINTAIN, OR OPERATE THIS EQUIPMENT WITHOUT READING, UNDERSTANDING, AND FOLLOWING THE PROPER **Elsag Bailey** INSTRUCTIONS AND MANUALS; OTHERWISE, INJURY OR DAMAGE MAY RESULT.

RADIO FREQUENCY INTERFERENCE

MOST ELECTRONIC EQUIPMENT IS INFLUENCED BY RADIO FREQUENCY INTERFERENCE (RFI). CAUTION SHOULD BE EXERCISED WITH REGARD TO THE USE OF PORTABLE COMMUNICATIONS EQUIPMENT IN THE AREA AROUND SUCH EQUIPMENT. PRUDENT PRACTICE DICTATES THAT SIGNS SHOULD BE POSTED IN THE VICINITY OF THE EQUIPMENT CAUTIONING AGAINST THE USE OF PORTABLE COMMUNICATIONS EQUIPMENT.

POSSIBLE PROCESS UPSETS

MAINTENANCE MUST BE PERFORMED ONLY BY QUALIFIED PERSONNEL AND ONLY AFTER SECURING EQUIPMENT CONTROLLED BY THIS PRODUCT. ADJUSTING OR REMOVING THIS PRODUCT WHILE IT IS IN THE SYSTEM MAY UPSET THE PROCESS BEING CONTROLLED. SOME PROCESS UPSETS MAY CAUSE INJURY OR DAMAGE.

AVERTISSEMENT

MANUELS D'OPÉRATION

NE PAS METTRE EN PLACE, RÉPARER OU FAIRE FONCTIONNER L'ÉQUIPEMENT SANS AVOIR LU, COMPRIS ET SUIVI LES INSTRUCTIONS RÉGLEMENTAIRES DE **Elsag Bailey**. TOUTE NÉGLIGENCE À CET ÉGARD POURRAIT ÊTRE UNE CAUSE D'ACCIDENT OU DE DÉFAILLANCE DU MATÉRIEL.

PERTURBATIONS PAR FRÉQUENCE RADIO

LA PLUPART DES ÉQUIPEMENTS ÉLECTRONIQUES SONT SENSIBLES AUX PERTURBATIONS PAR FRÉQUENCE RADIO. DES PRÉCAUTIONS DEVRONT ÊTRE PRISES LORS DE L'UTILISATION DU MATÉRIEL DE COMMUNICATION PORTATIF. LA PRUDENCE EXIGE QUE LES PRÉCAUTIONS À PRENDRE DANS CE CAS SOIENT SIGNALÉES AUX ENDROITS VOULUS DANS VOTRE USINE.

PERTURBATIONS DU PROCÉDÉ

L'ENTRETIEN DOIT ÊTRE ASSURÉ PAR UNE PERSONNE QUALIFIÉE EN CONSIDÉRANT L'ASPECT SÉCURITAIRE DES ÉQUIPEMENTS CONTRÔLÉS PAR CE PRODUIT. L'AJUSTEMENT ET/OU L'EXTRACTION DE CE PRODUIT PEUT OCCASIONNER DES À-COUPS AU PROCÉDÉ CONTRÔLE LORSQU'IL EST INSÉRÉ DANS UNE SYSTÈME ACTIF. CES À-COUPS PEUVENT ÉGALEMENT OCCASIONNER DES BLESSURES OU DES DOMMAGES MATÉRIELS.

NOTICE

The information contained in this document is subject to change without notice.

Elsag Bailey, its affiliates, employees, and agents, and the authors and contributors to this publication specifically disclaim all liabilities and warranties, express and implied (including warranties of merchantability and fitness for a particular purpose), for the accuracy, currency, completeness, and/or reliability of the information contained herein and/or for the fitness for any particular use and/or for the performance of any material and/or equipment selected in whole or part with the user of/or in reliance upon information contained herein. Selection of materials and/or equipment is at the sole risk of the user of this publication.

This document contains proprietary information of Elsag Bailey, Elsag Bailey Process Automation, and is issued in strict confidence. Its use, or reproduction for use, for the reverse engineering, development or manufacture of hardware or software described herein is prohibited. No part of this document may be photocopied or reproduced without the prior written consent of Elsag Bailey.

Preface

Termination units terminate and connect plant equipment to the INFI 90[®] strategic process management system. The NTAI06 Analog Input Termination Unit terminates field wiring for the IMASI03 Universal Analog Input Slave Module.

This manual explains how to install and use the NTAI06 on the INFI 90 system. It has sections that describe the setup and cabling. Appendix A contains quick reference information about the IMASI03 module.

[®] INFI 90 is a registered trademark of Eltag Bailey Process Automation.

List of Effective Pages

Total number of pages in this instruction is 30, consisting of the following:

Page No.	Change Date
Preface	Original
List of Effective Pages	Original
iii through vi	Original
1-1 through 1-5	Original
2-1 through 2-1	Original
3-1	Original
4-1 through 4-2	Original
5-1	Original
A-1 through A-2	Original
Index-1 through Index-2	Original

When an update is received, insert the latest changed pages and dispose of the superseded pages.

NOTE: On an update page, the changed text or table is indicated by a vertical bar in the outer margin of the page adjacent to the changed area. A changed figure is indicated by a vertical bar in the outer margin next to the figure caption. The date the update was prepared will appear beside the page number.

Safety Summary

GENERAL WARNINGS

Equipment Environment

All components, whether in transportation, operation or storage, must be in a noncorrosive environment.

Electrical Shock Hazard During Maintenance

Disconnect power or take precautions to insure that contact with energized parts is avoided when servicing.

SPECIFIC CAUTIONS

Remove modules (slave or termination) from their assigned slots before installing a cable to that slot. Failure to do so could result in damage to the module or station. (p. 2-7)

We strongly recommend turning off power before doing any termination unit wiring. Failure to do so could result in equipment damage. Do not apply power without verifying all wire connections. (p. 2-9, 4-1)

If input or output circuits are a shock hazard after disconnecting system power at the power entry panel, then the door of the cabinet containing these externally powered circuits must be marked with a warning stating that multiple power sources exist. (p. 2-11)

Sommaire de Sécurité

**AVERTISSEMENTS
D'ORDRE
GÉNÉRAL****Environnement de l'équipement**

Ne pas soumettre les composants à une atmosphère corrosive lors du transport, de l'entreposage ou l'utilisation.

Possibilité de chocs électriques durant l'entretien

Débrancher l'alimentation ou prendre les précautions pour éviter tout contact avec des composants sous tension durant l'entretien.

**ATTENTIONS
D'ORDRE
SPÉCIFIQUE**

Retirer les modules (asservi ou carte de raccordement) de leur position assignée avant d'installer un câble à cette position. Des dommages au module ou au poste pourraient résulter d'un manquement à cette procédure. (p. 2-7)

Il est fortement recommande de debracher l'alimentation electrique avant d'effectuer tout connexion aux cartes de raccordment des units. Des dommages aux equipments pourraient survenir dans le cas contraire. Ne pas rebrancher l'alimentation avant que toutes les connexions aient ete verifiees. (p. 2-9, 4-1)

Si des circuits d'entree ou de sortie sont alimentes a partir de sources externes, ils presentent un risque de choc electrique meme lorsque l'alimentation du systeme est debranchee du panneau d'entree l'alimentation. Le cas echeant, un avertissement signalant la presence de sources d'alimentation multiples doit etre appose sur la porte de l'armoire. (p. 2-11)

Table of Contents

	<i>Page</i>
SECTION 1 - INTRODUCTION	1-1
OVERVIEW	1-1
INTENDED USER.....	1-1
TERMINATION UNIT DESCRIPTION	1-1
FEATURES.....	1-2
INSTRUCTION CONTENT	1-3
HOW TO USE THIS MANUAL	1-4
GLOSSARY OF TERMS AND ABBREVIATIONS	1-4
REFERENCE DOCUMENTS.....	1-4
NOMENCLATURE	1-5
SPECIFICATIONS.....	1-5
SECTION 2 - INSTALLATION	2-1
INTRODUCTION.....	2-1
SPECIAL HANDLING	2-1
UNPACKING AND INSPECTION	2-2
SETUP/INSTALLATION	2-2
Fuses.....	2-2
Jumper Settings	2-3
Installing the Termination Unit	2-4
Cable Connections	2-6
Terminal Block Wiring	2-9
Power Wiring.....	2-9
SECTION 3 - MAINTENANCE	3-1
INTRODUCTION.....	3-1
MAINTENANCE SCHEDULE	3-1
SECTION 4 - REPAIR/REPLACEMENT PROCEDURES	4-1
INTRODUCTION.....	4-1
REPLACEMENT PROCEDURES.....	4-1
Replacing Fuses.....	4-2
SECTION 5 - SUPPORT SERVICES	5-1
INTRODUCTION.....	5-1
REPLACEMENT PARTS AND ORDERING INFORMATION	5-1
TRAINING	5-1
TECHNICAL DOCUMENTATION	5-1
APPENDIX A - UNIVERSAL ANALOG SLAVE INPUT MODULE (IMASI03)	A-1
INTRODUCTION.....	A-1

List of Figures

<i>No.</i>	<i>Title</i>	<i>Page</i>
1-1.	Application Example for NTAI06	1-2
2-1.	Jumper Locations and Terminal Assignments for NTAI06 Revision A Hardware (6639364A1)	2-3
2-2.	Jumper Locations and Terminal Assignments for NTAI06 Revision B Hardware (6639364B1)	2-4
2-3.	Typical Input Circuit for NTAI06	2-5
2-4.	Installation for Revision A and B Hardware NTAI06	2-7
2-5.	Cable Connections for NTAI06	2-8
2-6.	Field Input Termination Examples for NTAI06	2-9
2-7.	NTAI06 Connection Examples	2-10
A-1.	Address Select Switch (SW1) and Jumper Locations	A-1

List of Tables

<i>No.</i>	<i>Title</i>	<i>Page</i>
1-1.	Glossary of Terms and Abbreviations	1-4
1-2.	Reference Documents	1-4
1-3.	Nomenclature	1-5
1-4.	Specifications	1-5
2-1.	NTAI06 Jumper Configurations	2-5
2-2.	NTAI06 Input Types	2-6
2-3.	NTAI06 Input Type Descriptions	2-6
2-4.	NTAI06 Cable Applications	2-8
3-1.	Maintenance Schedule	3-1
5-1.	Spare Parts List	5-1
A-1.	IMASI03 Address Switch Settings (SW1)	A-2
A-2.	IMASI03 Jumper Configurations	A-2
A-3.	IMASI03 Jumpers Used for Each Channel	A-2

SECTION 1 - INTRODUCTION

OVERVIEW

The IMASIO3 Universal Analog Slave Module uses the NTAIO6 Analog Input Termination Unit to terminate sixteen analog signals from field equipment. The signals pass through the IMASIO3 to the IMMFP01, IMMFP02 and IMMFP03 Multi-Function Processor. This manual explains the purpose, set up, handling precautions and steps to install the NTAIO6 termination unit. Refer to the **Table of Contents** to find the information. Refer to **HOW TO USE THIS MANUAL** to get started.

INTENDED USER

System engineers and technicians should read this manual before installing and using the termination unit (TU). Put the termination unit and slave module into operation only after reading and understanding this instruction.

TERMINATION UNIT DESCRIPTION

The NTAIO6 is a single printed circuit board that mounts in a NFTP01 Field Termination Panel. The termination unit (TU) has two connectors P1 and P2. A single Y-shaped cable connects to P1 and P2 on the termination unit. The other end of the cable connects to the slave module. The terminal blocks for field wiring are on the TU. Jumpers on the NTAIO6 are set to match the type of input signal. Figure 1-1 shows an application example for the NTAIO6.

The NTAIO6 handles up to 16 analog inputs. Each voltage input may be differential or single ended. The IMASIO3 can input these analog signal ranges:

- 1 to 5 VDC.
- 0 to 5 VDC.
- 0 to 10 VDC.
- -10 to +10 VDC, or user specified range within ± 10 VDC.
- System powered 4 to 20 mA DC.
- Externally powered 4 to 20 mA DC.
- Three-wire RTD.
- -100 to 100 mV.
- Thermocouple inputs.

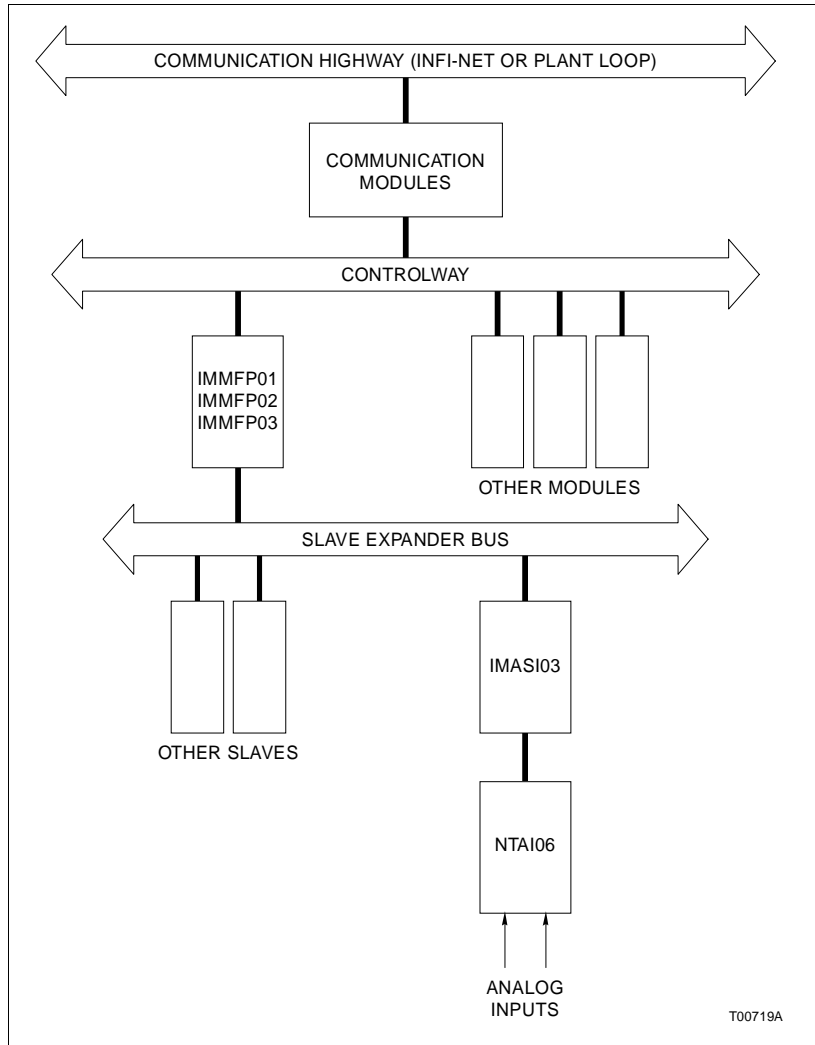

Figure 1-1. Application Example for NTAI06

FEATURES

The design of the NTAI06, as with all INFI 90 devices, allows for flexibility in creating a process management system. Refer to **NOMENCLATURE** for a list of devices that can be used with this TU in the INFI 90 system.

- A standard factory-wired cable connects the TU to the slave module.
- On-board compression fitting type terminal blocks accept field wiring for 16 inputs.
- Each TU fits in a standard field termination panel.
- 4 to 20 mA inputs may be either system or externally powered.

- Input channel transient and surge protection.
- Analog input signal routing to the IMASI03.
- Jumper configured input signal types:
 - System powered 4 to 20 mA inputs have individually fused channels.
 - Field powered 4 to 20 mA.
 - Single ended voltage inputs have the minus input terminal jumpered directly to I/O COM on the NTAI06.
 - Differential voltage inputs and three-wire RTDs have the plus and minus and C terminals isolated with respect to I/O COM and module common.
- Source of the local cold junction reference for thermocouple inputs.
- Termination point for the shield of the NKAS01 or NKAS11 cable.
- The termination unit can be located up to 60 meters (200 feet) from the IMASI03.

INSTRUCTION CONTENT

This manual has five sections and an appendix.

Introduction	Is an overview of the features, description and specifications and a description of the NTAI06.
Installation	Describes cautions to observe when handling the TU. It shows the steps to follow to install and connect the termination unit before applying power. This section also presents jumper settings.
Maintenance	Provides a maintenance schedule.
Repair/Replacement Procedures	Details how to replace a TU.
Support Services	Describes the support services (spare parts, training, documentation, etc.) available from Bailey Controls Company.
Appendix A	Shows the jumper settings, board layout and cabling for the IMASI03 Universal Analog Slave Input Module.

HOW TO USE THIS MANUAL

Read this manual before handling the TU. Refer to the sections in this list as needed for more information.

1. Read **Section 2** before connecting the NTAI06.
2. Refer to **Appendix A** for the IMASI03 slave module.
3. Refer to **Section 3** for a maintenance schedule.
4. Refer to the repair/replacement procedures and support services when needed.

GLOSSARY OF TERMS AND ABBREVIATIONS

Table 1-1 contains the glossary of terms for this manual.

Table 1-1. Glossary of Terms and Abbreviations

Term	Definition
Analog	A continuous time signal with an infinite number of values.
Cold Junction Reference	The ambient temperature at the bimetallic junction at the termination point of thermocouple wires.
FTP	Field Termination Panel. A panel inside the INFI 90 cabinet on which to mount termination units.
RTD	Resistance Temperature Detector. A sensing device that changes resistance with changes in temperature.
Slave Module	One of a series of modules designed to perform input/output operations as directed by a master module.
Thermocouple	A bi-metallic sensor used for temperature measurements.
TU	Termination Unit. Provides input/output connection between plant equipment and the INFI 90/Network 90 [®] modules.

REFERENCE DOCUMENTS

Table 1-2 contains the reference documents for the NTAI06.

Table 1-2. Reference Documents

Number	Document
I-E96-301	Universal Analog Input Slave Module (IMASM03)
I-E96-500	Site Planning and Preparation

[®] Network 90 is a registered trademark of Eltag Bailey Process Automation.

NOMENCLATURE

Table 1-3 contains the modules and equipment that can be used with the NTAIO6:

Table 1-3. Nomenclature

Nomenclature	Description
IEFAS01	INFI 90 Fastener Kit
IMASI03	Universal Analog Input Slave Module
NKAS01	Cable, Termination Unit (PVC)
NKAS11	Cable, Termination Unit (non-PVC)
NFTP01	Field Termination Panel

SPECIFICATIONS

Refer to Table 1-4 for the specifications of the NTAIO6 Termination Unit.

Table 1-4. Specifications

Property	Characteristic/Value
Power Requirements	+ 24 VDC required if system powered 4 - 20 mA inputs are used.
Mounting	Mounts in the Field Termination Panel (NFTP01).
Environmental	
Electromagnetic/Radio Frequency Interference	No values available at this time. Keep cabinet doors closed. Do not use communication equipment closer than 2 meters from the cabinet.
Ambient Temperature	0° to 70° C (32° to 158° F)
Relative Humidity	5% to 90% ± 5% up to 55° C (131° F) (non-condensing)
	5% to 40% ± 5% at 70° C (158° F) (non-condensing)
Atmospheric Pressure	Sea level to 3 km (1.86 miles)
Air Quality	Noncorrosive
Cooling Requirements	No cooling is necessary when used in Bailey Controls cabinets and operated within stated limits.
Certification	CSA certified for use as process control equipment in an ordinary (nonhazardous) location.

SPECIFICATIONS SUBJECT TO CHANGE WITHOUT NOTICE

SECTION 2 - INSTALLATION

INTRODUCTION

This section explains how to install the NTAI06 Analog Slave Input Termination Unit. For proper operation, read, understand, and complete the steps in the order they appear before using the NTAI06.

SPECIAL HANDLING

Observe these steps when handling electronic circuitry:

NOTE: Always use the Bailey Controls Field Static Kit (part number 1948385A1 - consisting of two wrist straps, ground cord assembly, alligator clip, and static dissipating work surface) when working with modules. The kit is designed to connect the technician and the static dissipating work surface to the same ground point to prevent damage to the modules by electrostatic discharge.

Use the static grounding wrist strap when installing and removing modules. Static discharge may damage MOS devices on modules in the cabinet. Use grounded equipment and static safe practices when working with modules.

1. **Use Antistatic Bag.** Keep the modules in the antistatic bag until you are ready to install them in the system. Save the bag for future use.
2. **Ground Bags Before Opening.** Before opening a bag containing an assembly with CMOS devices, touch it to the equipment housing or ground to equalize charges.
3. **Avoid Touching Circuitry.** Handle assemblies by the edges; avoid touching the circuitry.
4. **Avoid Partial Connection of CMOS Device.** Verify that all devices connected to the modules are properly grounded before using them.
5. **Ground Test Equipment.**
6. **Use an Antistatic Field Service Vacuum** to remove dust from the module if necessary.
7. **Use a Grounded Wrist Strap.** Connect the wrist strap to the appropriate grounding plug on the power entry panel. The grounding plug on the power entry panel is connected to the cabinet chassis ground.

UNPACKING AND INSPECTION

These are steps to follow for general handling:

1. Examine the unit to make sure that no damage has occurred in transit.
2. Notify the nearest Bailey Controls sales office of any damage.
3. File a claim for any damage with the shipping company that handled the shipment.
4. Use the original packing material or container to store the unit.
5. Store the unit in a place with clean air; free of extremes of temperature and humidity.

SETUP/INSTALLATION

This section explains how to configure and install the NTAI06. The required procedures are: setting the jumpers, mounting the termination unit to the field termination panel and connecting the field wiring and termination cables. There are two revisions of the NTAI06. Revision A hardware (assembly number 6639364A1) has a fuse F17. Revision B hardware (assembly number 6639364B1) has additional filter capacitors.

Each NTAI06 termination unit has a pair of resistance temperature detectors (RTDs) which measure the local temperature of the field wire to terminal block connection. This temperature is used to compensate for the cold junction effect on thermocouple inputs.

When using the built-in cold junction reference, the termination unit cover should be in place. The cover encloses both the terminal blocks and the RTDs. It helps maintain the same temperature around the terminal blocks and the RTDs. Maintaining both at the same temperature allows maximum accuracy for thermocouple inputs. Always keep the cover on during operation when thermocouple inputs are connected. Refer to ***Jumper Settings***.

Fuses

Fuses F1 to F16 are shipped installed in fuse clips F1 to F16. They are 31.25 milliamp, 125 volt fuses, (Bailey part number 1945820A10310). Revision A (assembly number 6639364A1) also has one fuse F17. It is a 2.0 amp, 250 volt fuse, (Bailey part number 1948182A32001). The fuse is shipped installed on the revision A assembly termination units in fuse clip F17.

Jumper Settings

Jumpers on the termination unit configure the 16 analog inputs. See Figure 2-1 and 2-2 for jumper locations and terminal assignments.

Jumpers on the termination unit configure each of the 16 analog inputs to match the signal type of the device connected to that input. Each channel is independent. The selection includes: voltage or current input, differential or single ended voltage, system externally powered, four to 20 milliamp, or 3 wire RTD inputs. Set the jumpers according to the tables in this section. To enable the input type, short the appropriate pins together with a jumper.

Figure 2-3 shows a typical input circuit for the NTAI06. Table 2-1 lists the jumper configurations for the TU. Table 2-2 lists the devices that can connect to the TU. Table 2-3 describes the input types. Jumpers used by each input channel are listed with the field termination example later in this section.

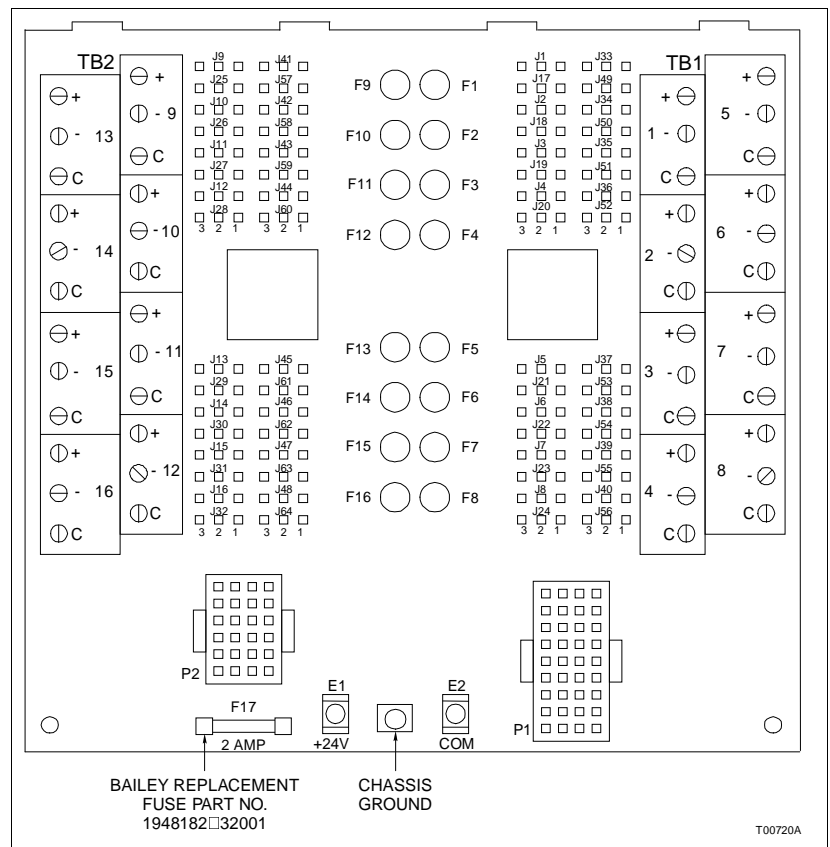

Figure 2-1. Jumper Locations and Terminal Assignments for NTAI06 Revision A Hardware (6639364A1)

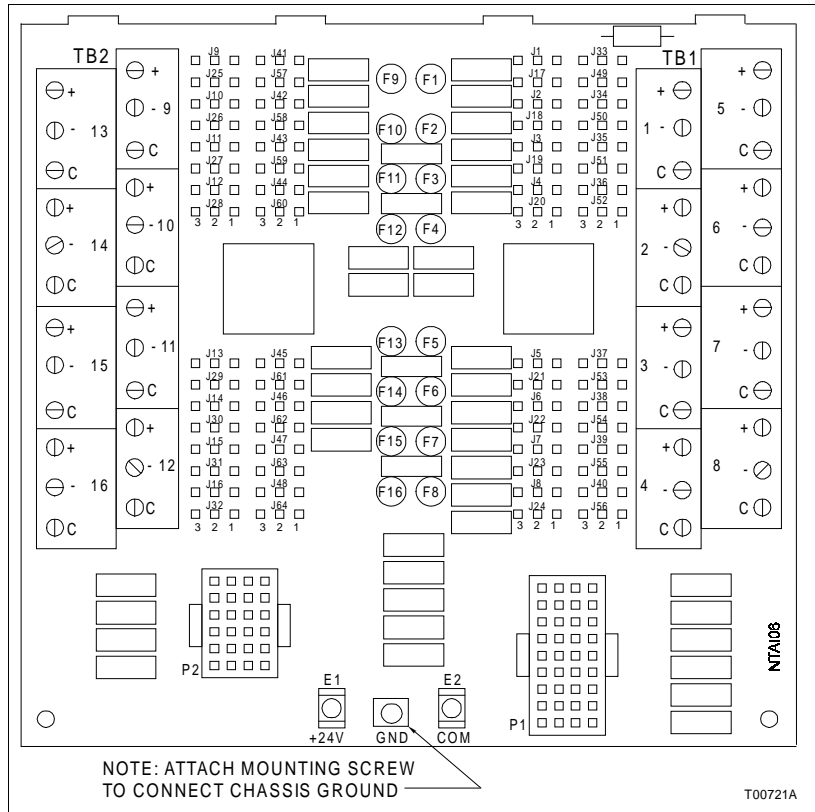

Figure 2-2. Jumper Locations and Terminal Assignments for NTAI06 Revision B Hardware (6639364B1)

Installing the Termination Unit

The TU mounts on a standard NFTP01 Field Termination Panel. Figure 2-4 shows how to secure the termination unit to the FTP.

To install the termination unit:

1. Make sure power is off to the cabinet.
2. Insert the termination unit tabs into the slots in the outside edge of the termination panel.
3. Mount the TU to the field termination panel with two number 10, 3/4 inch screws. Do not over tighten the screws. See Figure 2-4.
4. Install the chassis ground using a number 10 self-tapping screw and external star lock washer. Do not overtighten.

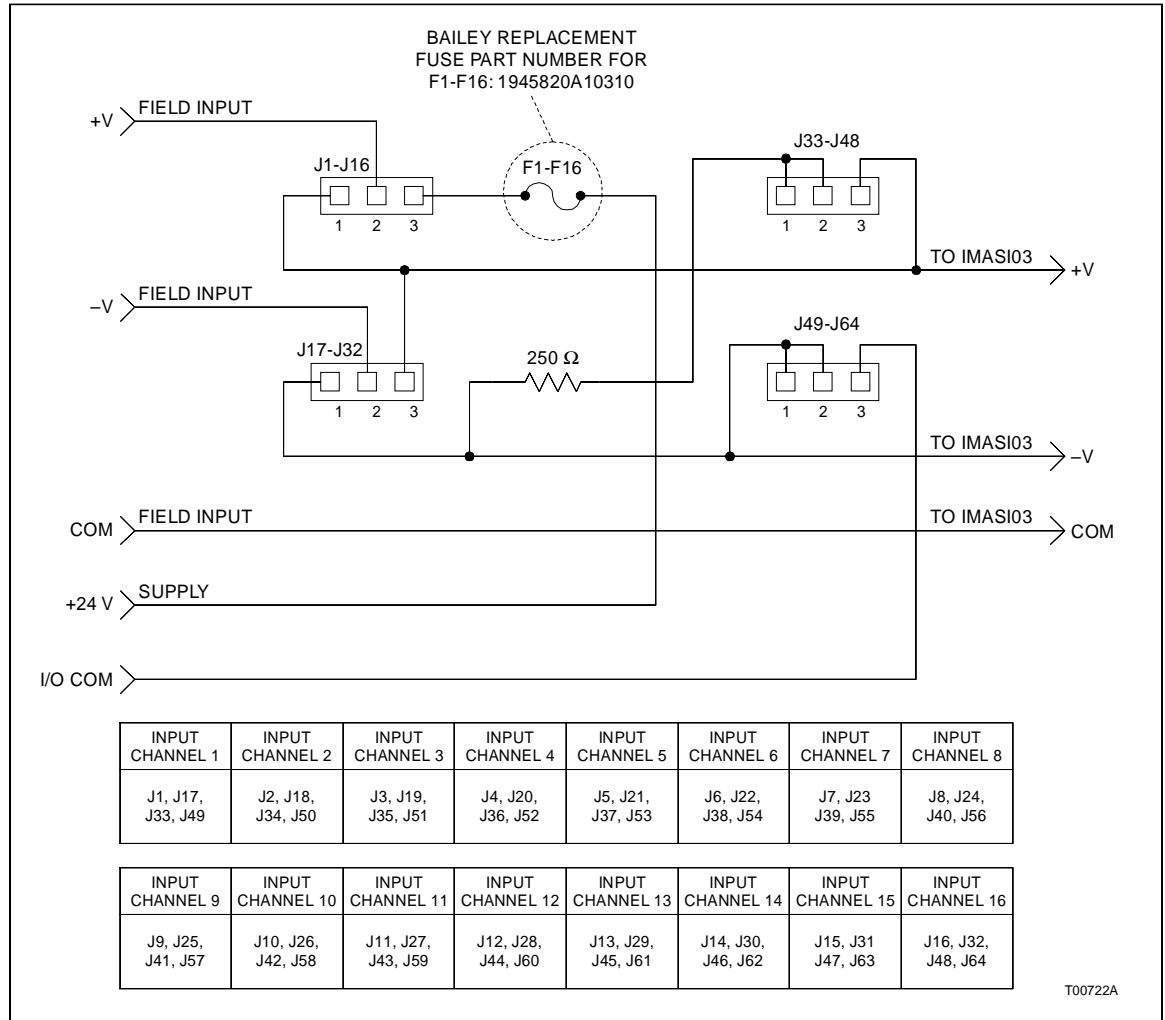

Figure 2-3. Typical Input Circuit for NTAI06

Table 2-1. NTAI06 Jumper Configurations

Input Type	Jumper Number		
	J1 - J32	J33 - J48	J49 - J64
Single ended voltage	1 - 2	1 - 2	2 - 3
Differential voltage	1 - 2	1 - 2	1 - 2
System powered 4 - 20 mA	2 - 3	2 - 3	2 - 3
External powered 4 - 20 mA	1 - 2	2 - 3	1 - 2
3-wire RTD	1 - 2	1 - 2	1 - 2

Table 2-2. NTAI06 Input Types

Input Type	Signal Type
Thermocouple	TC Types: E, J, K, L, N, (14 AWG), N (28 AWG), R, S, T, U, Chinese E, Chinese S
Millivolt	mV range: -100 mV to +100 mV
High Level	H.L. range: -10 V to + 10 V
Current	4 - 20 mA, external or system powered
3-wire RTD	10 ohm, 100 ohm, 120 ohm, Chinese 53 ohm

Table 2-3. NTAI06 Input Type Descriptions

Input Type	Input Description
Single ended voltage	This jumper configuration connects the minus (-) input terminal to I/O COM on the NTAI06. The IMASI03 measures the voltage at the plus (+) input terminal with respect to the I/O COM terminal. No connection to the C terminal is necessary.
Differential voltage	This jumper configuration connects the plus (+) and minus (-) inputs directly to IMASI03 differential input. Channel to channel and channel to system common signal isolation is achieved for all voltage input types, including high level voltage, millivolts and thermocouples. No connection to the C terminal is necessary.
System powered 4 - 20 mA	This jumper configuration connects the plus (+) input terminal to system +24 VDC through a fuse on the NTAI06. The minus (-) input terminal connects to a precision resistor that generates a single ended voltage (1-5 V) for the IMASI03 to measure. No connection to the C terminal is necessary. INFI 90 must have +24 V (system power) installed.
External powered 4 - 20 mA	This jumper configuration connects the plus (+) input terminal to one end of a precision resistor and the minus (-) input to the other end of the same precision resistor in the NTAI06. An isolated 1-5 V is generated for the IMASI03 to measure. No connection to the C terminal is necessary.
3-wire RTD	This jumper configuration connects the plus (+) and minus (-) inputs and the COM input directly to IMASI03 three-wire input. Channel to channel and channel to system signal isolation is maintained. The two common leads of the RTD element should be connected across the plus (+) and common (C) terminals, and the third lead should be connected to the minus (-) terminal.

Cable Connections

The NTAI06 has two cable connectors, P1 and P2, where the TU cable connects. Install a NKAS01 or NKAS11 cable into the connector on the TU.

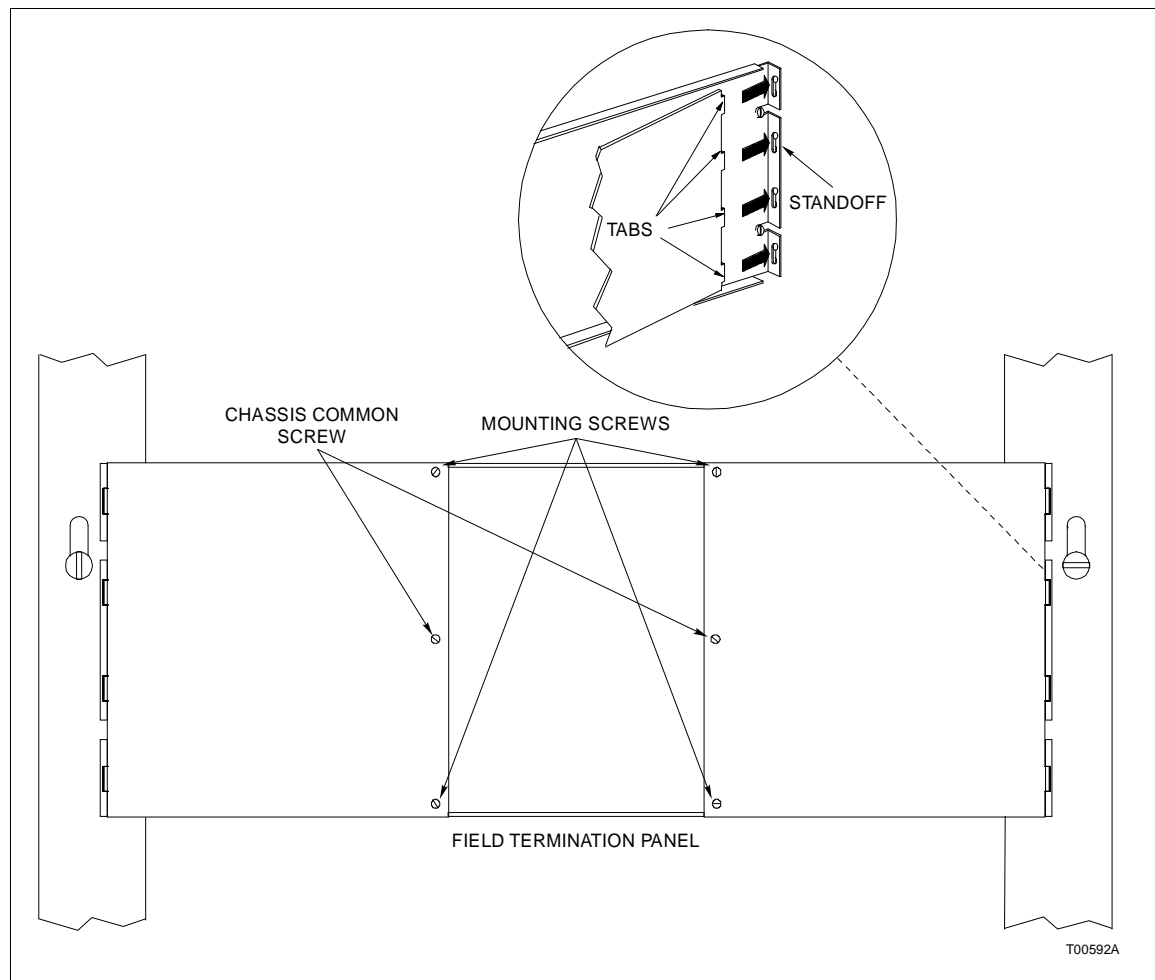

Figure 2-4. Installation for Revision A and B Hardware NTAI06

CAUTION	Remove modules (slave or termination) from their assigned slots before installing a cable to that slot. Failure to do so could result in damage to the module or station.
ATTENTION	Retirer les modules (asservi ou carte de raccordement) de leur position assignée avant d'installer un câble à cette position. Des dommages au module ou au poste pourraient résulter d'un manquement à cette procédure.

The NKAS01 and NKAS11 are round, shielded cables that connect the TU to the IMASI03 slave module. The NKAS01 cable has a PVC jacket and is rated for 80 degrees celsius at 300 volt (UL rated type CL2). The NKAS11 cable has a non-PVC jacket and is rated for 90 degrees celsius at 300 volt (UL rated type PLTC). See Figure 2-5 for the cable connections from the termination unit to the slave module. Table 2-4 lists the NTAI06 cable applications.

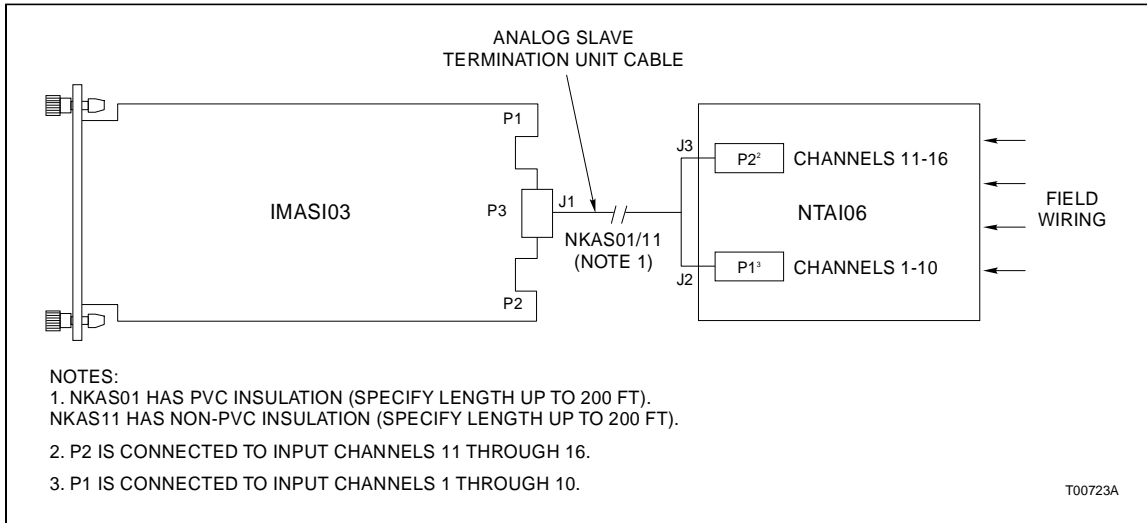

Figure 2-5. Cable Connections for NTAI06

Table 2-4. NTAI06 Cable Applications

Nomenclature/Description	Application	Connector	Maximum Length
NKAS01 (PVC)	Connects TU to IMASI03	P1 and P2 on TU to MMU backplane.	61 m (200 ft)
NKAS11 (non-PVC)	Connects TU to IMASI03	P1 and P2 on TU to MMU backplane.	61 m (200 ft)

To install the cable follow these steps.

1. Verify IMASI03 is unplugged from the MMU backplane.
2. Connect the hooded end (J1) of the cable (NKAS01 or NKAS11) to the MMU backplane. To do this, insert the connector into the same backplane slot as assigned to the slave module. Snap the latches securely into place.
3. Insert the male 36 pin connector (J2) end of the cable into the P1 connector of the TU. The cable should latch securely in place.
4. Insert the male 24 pin connector (J3) end of the cable into the P2 connector of the TU. The cable should latch securely in place.
5. Slide the IMASI03 into the MMU until the module is fully seated and the faceplate is flush with the front of the rack.

Terminal Block Wiring

CAUTION

We strongly recommend turning off power before doing any termination unit wiring. Failure to do so could result in equipment damage. Do not apply power without verifying all wire connections.

ATTENTION

Il est fortement recommande de debrancher l'alimentation electrique avant d'effectuer tout connexion aux cartes de raccordement des units. Des dommages aux equipments pourraient survenir dans le cas contraire. Ne pas rebrancher l'alimentation avant que toutes les connexions aient ete verifiees.

Connect the wiring from the process input devices to the TU terminals. See Figure 2-6 for terminal block assignments and wiring polarity. Figure 2-7 shows NTAI06 cabling and input examples. Field wiring should be 12 to 22 AWG wire. Refer to the Site Planning and Preparation manual for information on field wiring such as noise immunity and spacing requirements.

Power Wiring

This section explains how to connect power wiring. The NTAI06 has two fast-on connections for power and I/O common. There is a chassis ground point on the edge of the circuit board between the power and ground connectors. A screw and external star washer connect the chassis common point to the NFTP01. Make power connections to the TU after it is mounted in the NFTP01. Make sure cabinet and I/O power are turned off before connecting ground and power wiring.

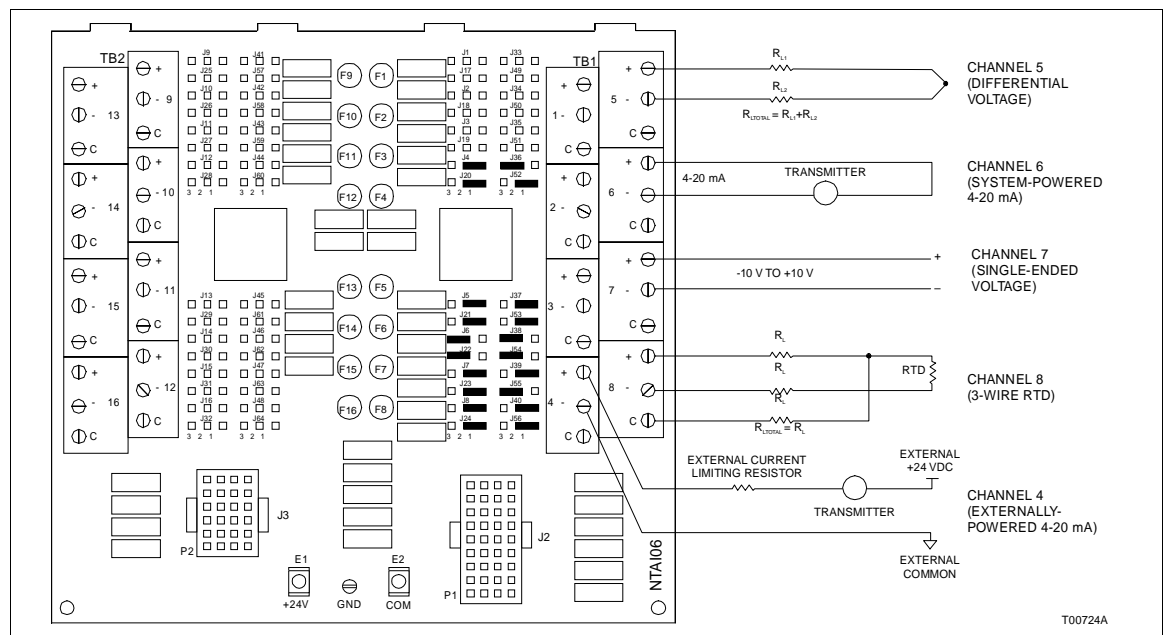
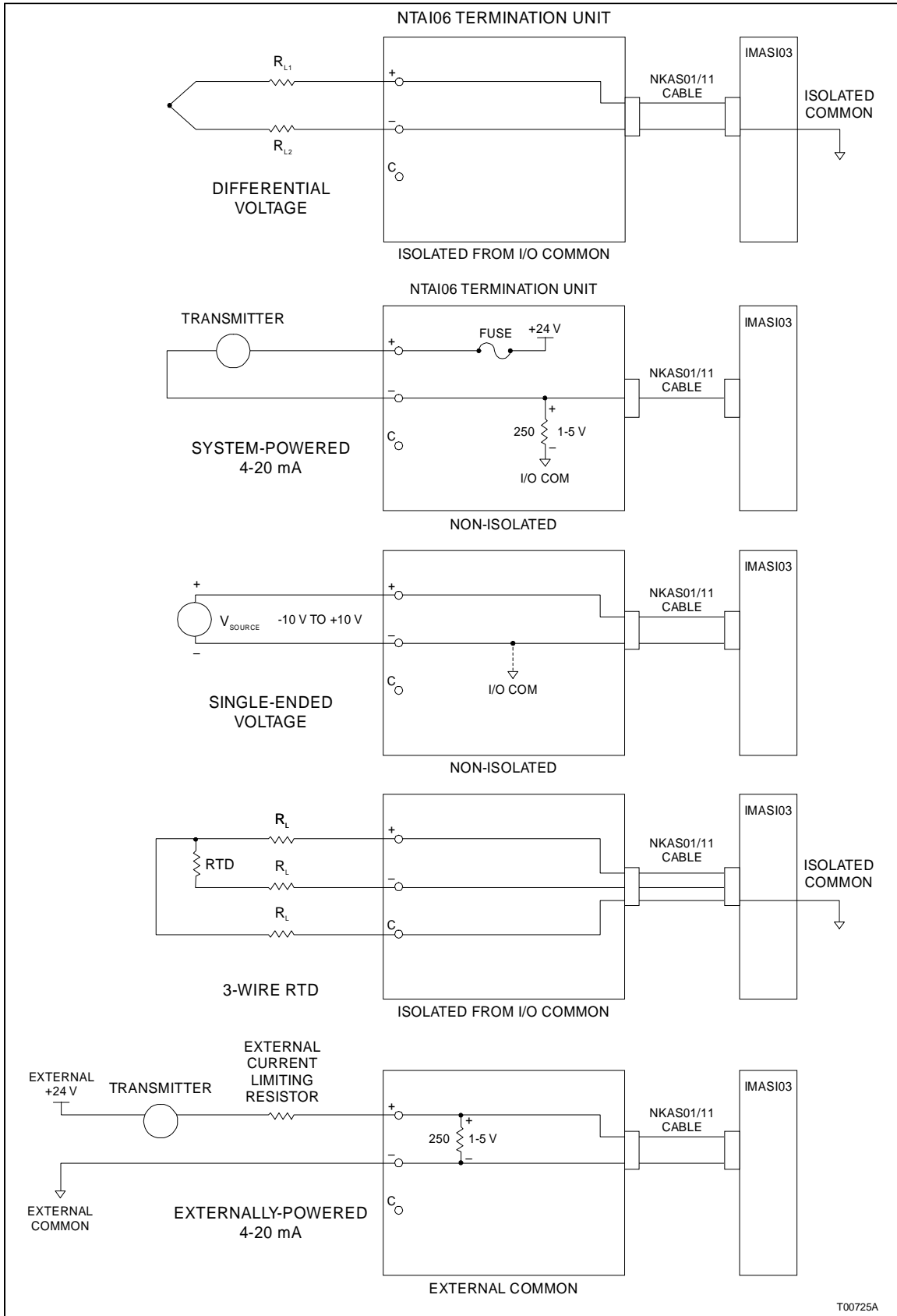

Figure 2-6. Field Input Termination Examples for NTAI06



T00725A

Figure 2-7. NTAI06 Connection Examples

CAUTION

If input or output circuits are a shock hazard after disconnecting system power at the power entry panel, then the door of the cabinet containing these externally powered circuits must be marked with a warning stating that multiple power sources exist.

ATTENTION

Si des circuits d'entree ou de sortie sont alimentes a partir de sources externes, ils presentent un risque de choc electrique meme lorsque l'alimentation du systeme est debranchee du panneau d'entree l'alimentation. Le cas echeant, un avertissement signalant la presence de sources d'alimentation multiples doit etre appose sur la porte de l'armoire.

Use 14 gauge wire for power wiring. To connect power to the termination unit in a system using modular power supplies:

1. Attach a wire from the system +24 VDC supply to the E1 fast-on connector.
2. Attach a 14 AWG wire from the DC bus bar at the bottom of the cabinet to the E2 fast-on connector.

The NTAIO6 is ready for operation if:

1. The required jumpers are set.
2. The circuit board is mounted in the termination unit mounting unit.
3. All required cables are connected to the termination unit.
4. All required field wires are connected to the termination unit and have been verified.
5. The termination unit cover is installed for the cold junction reference.
6. Power is connected and applied to the termination unit.

SECTION 3 - MAINTENANCE

INTRODUCTION

The RTD analog input termination unit requires limited maintenance. This section contains a maintenance schedule.

MAINTENANCE SCHEDULE

Execute the tasks in Table 3-1 at the specified intervals.

Table 3-1. Maintenance Schedule

Task	Interval
Clean and tighten all power and grounding connections	Every 6 months or during plant shutdown, whichever occurs first.
Use a static safe vacuum cleaner to remove dust from: Field termination panel Termination units	

SECTION 4 - REPAIR/REPLACEMENT PROCEDURES

INTRODUCTION

This section explains the replacement procedures for the NTAI06 Analog Input Termination Unit.

REPLACEMENT PROCEDURES

If a TU is faulty, replace it with a new one. DO NOT try to repair the TU. Replacing components may affect performance and certification.

CAUTION	We strongly recommend that all power (cabinet, I/O, etc. be turned off before doing any termination unit wiring. Failure to do so could result in equipment damage. Do not apply power until all connections are verified.
ATTENTION	Il est fortement recommande que toutes les alimentations (armoire, E/S, etc.) soient coupees avant d'effectuer quelque raccord que ce soit sur une carte de raccordement. Un manquement a ces instructions pourrait causer des dommages a l'equipement. Ne pas rebrancher les alimentations avant d'avoir verifie tous les raccords.

To replace a termination unit:

1. Turn OFF the INFI 90 cabinet power or unplug the slave module from the MMU backplane.

NOTE: The I/O power supplies providing the power to the TU may not be located in the same cabinet as the TU. Make sure to turn OFF power to any external supplies providing I/O power.

2. Remove the four nylon screws and remove the RTD cover.
3. Label and remove all field wiring from the terminal blocks.
4. Label and disconnect all cables connected to the TU.
5. Label and disconnect system I/O power and ground from the terminals.
6. Remove the two screws securing the TU to the field termination panel and the chassis common screw and remove the TU.
7. Install the jumpers on the new TU according to installation instructions. Verify the jumpers on the replacement TU.

8. Insert the tabs of the circuit board into the proper slots of the field termination panel standoff and slide the circuit board into position.
9. Secure the termination unit circuit board to the field termination panel with two screws. Do not overtighten.
10. Install the chassis ground screw and number 10 external star washer. Do not overtighten.
11. Reconnect all field wiring removed in Step 2.
12. Reconnect the system I/O power wires and system ground wires removed in Step 3 and verify connections.
13. Reconnect all cables removed in Step 4.
14. Replace the RTD cover and the four nylon screws. Do not overtighten.
15. Energize the cabinet power supply that provides power to the TU.
16. Turn on any external power supplies providing I/O power.
17. Plug in the slave module to the MMU backplane.

Replacing Fuses

Replace the fuses by following these steps:

1. Turn off INFI 90 cabinet power.
2. Remove the four nylon screws and remove the cover.
3. Install the replacement 31.25 milliamp fuse into fuse socket F1 to F16 (See Figure 2-1 and 2-2 for fuse socket locations).
4. For revision A units, install the replacement 2.0 amp fuse into fuse holder F17.
5. Replace the cover and the four nylon screws. Do not overtighten.
6. Turn on power to the termination unit.

SECTION 5 - SUPPORT SERVICES

INTRODUCTION

Bailey Controls Company is ready to help in the use, application and repair of its products. Contact the nearest sales office to make requests for sales, applications, installation, repair, overhaul and maintenance contract services.

REPLACEMENT PARTS AND ORDERING INFORMATION

When making repairs or order replacement parts from a Bailey Controls sales office. Provide this information:

1. Part description, part number and quantity.
2. Model and serial numbers (if applicable).
3. Bailey instruction manual number, page number and reference figure that identifies the part.

Order parts without commercial descriptions from the nearest Bailey Controls Company sales office.

Table 5-1. Spare Parts List

Component	Description	Bailey Controls Part Number
Fuse F17	2.0 A slow blow 250 V 5 x 20 mm (0.192 x 0.787 in)	1948182A32001
Fuse F1 - F16	31 mA 125 V diameter: 6.35 mm (0.25 in) height: 8.89 mm (0.35 in)	1945820A10310

TRAINING

The Bailey Controls Company has a modern training facility that provides service and repair instruction. On-site training is also available. Contact a Bailey Controls Company sales office for specific information and scheduling.

TECHNICAL DOCUMENTATION

Additional copies of this manual, or other Bailey Controls Company manuals, can be obtained from the nearest Bailey Controls Company sales office at a reasonable charge.

APPENDIX A - UNIVERSAL ANALOG SLAVE INPUT MODULE (IMASI03)

INTRODUCTION

The IMASI03 Universal Analog Slave Input Module uses the NTAI06 to terminate analog inputs. Jumpers on the NTAI06 Termination Unit configure up to 16 analog inputs for the IMASI03. Each NTAI06 accepts analog inputs for either system powered four to 20 milliamp, externally powered four to 20 milliamp, three-wire RTD, differential or single ended voltage.

This appendix contains figures and tables that show the dipswitch and jumper locations on the IMASI03 and their settings. This information is provided as a quick reference guide for personnel installing the NTAI06. Figure A-1 shows the address select switch (SW1) and jumper locations. Table A-1 lists the binary addresses for setting SW1. Table A-2 lists the jumper configurations for the IMASI03. Table A-3 lists the jumpers set to configure each channel on the IMASI03. Refer to the IMASI03 product instruction for more information.

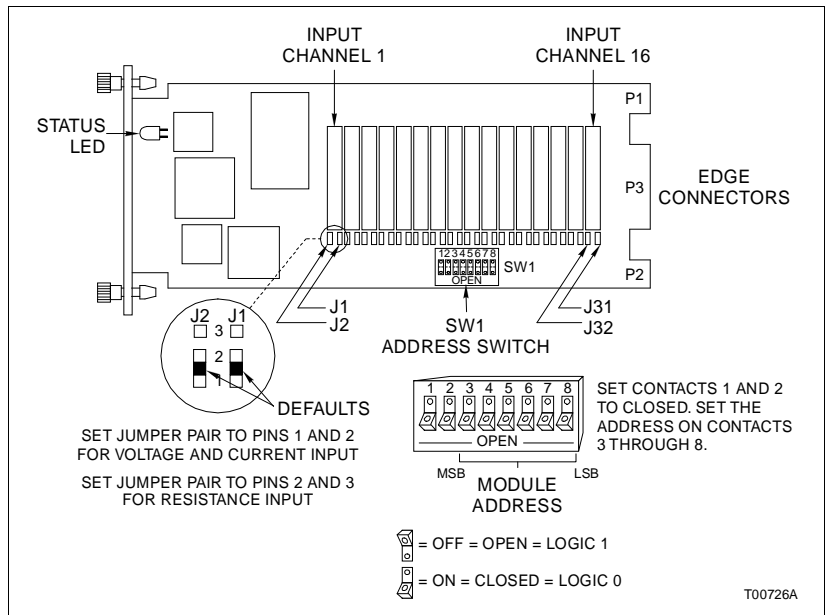

Figure A-1. Address Select Switch (SW1) and Jumper Locations

Table A-1. IMASI03 Address Switch Settings (SW1)

Address Example	MSB								LSB	Address Example	MSB								LSB
	1	2	3	4	5	6	7	8	1		2	3	4	5	6	7	8		
0	0	0	0	0	0	0	0	0	32	0	0	1	0	0	0	0	0		
9	0	0	0	0	1	0	0	1	41	0	0	1	0	1	0	0	1		
16	0	0	0	1	0	0	0	0	48	0	0	1	1	0	0	0	0		
31	0	0	0	1	1	1	1	1	63	0	0	1	1	1	1	1	1		

Table A-2. IMASI03 Jumper Configurations

Analog Input Type	Jumper Position	Jumper Number
Current Thermocouples High Level Voltage	1 - 2	J1 - J32 (Analog Input 1 through Analog Input 16)
Low Level Voltage Three-Wire RTD	2 - 3	J1 - J32 (Analog Input 1 through Analog Input 16)

Table A-3. IMASI03 Jumpers Used for Each Channel

Channel Number	Jumper Number		Channel Number	Jumper Number	
1	J1	J2	9	J17	J18
2	J3	J4	10	J19	J20
3	J5	J6	11	J21	J22
4	J7	J8	12	J23	J24
5	J9	J10	13	J25	J26
6	J11	J12	14	J27	J28
7	J13	J14	15	J29	J30
8	J15	J16	16	J31	J32

Index

A		J	
Application example	1-2	Jumper configurations	2-5
C		Jumper locations Revision A Hardware (6639364A1)	2-3
Cable applications	2-6	Jumper locations Revision B Hardware (6639364B1)	2-4
Cable connections	2-6	M	
Connection examples	2-9	Maintenance	3-1
F		Maintenance schedule	3-1
Features	1-2	N	
Fuses	2-2, 4-2	Nomenclature	1-5
G		O	
Glossary of terms and abbreviations	1-4	Overview	1-1
H		R	
How to use this manual	1-4	Reference documents	1-4
I		Replacement parts information	5-1
I/O wiring	2-9	Replacement parts/ordering information	5-1
IMASI03		Replacement procedures	4-1
Address select switch (SW1)	A-1	Replacing fuses	4-2
Address switch settings (SW1)	A-2	S	
Jumper configurations	A-2	Setup/installation	2-2
Jumper locations	A-1	Cable connections	2-6
Jumpers used for each channel	A-2	Fuses	2-2
Input circuit	2-5	Installing the termination unit	2-4
Input termination examples	2-9	Jumper settings	2-3
Input type descriptions	2-6	Power wiring	2-9
Input types	2-6	Terminal block wiring	2-9
Installation	2-1	Spare parts list	5-1
Installation for Revision A and Revision B Hardware	2-6	Special handling	2-1
Instruction content	1-3	Specifications	1-5
Introduction	1-1	Support services	5-1

Index (continued)

T			
Technical documentation	5-1	Termination unit description	1-1
Terminal assignments Revision A Hardware (6639364A1)	2-3	Training.....	5-1
Terminal assignments Revision B Hardware (6639364B1)	2-4		

U	
Unpacking and inspection	2-2

Visit Elsasg Bailey on the World Wide Web at <http://www.bailey.com>

Our worldwide staff of professionals is ready to meet *your* needs for process automation.
For the location nearest you, please contact the appropriate regional office.

AMERICAS

29801 Euclid Avenue
Wickliffe, Ohio USA 44092
Telephone 1-216-585-8500
Telefax 1-216-585-8756

ASIA/PACIFIC

152 Beach Road
Gateway East #20-04
Singapore 189721
Telephone 65-391-0800
Telefax 65-292-9011

EUROPE, AFRICA, MIDDLE EAST

Via Puccini 2
16154 Genoa, Italy
Telephone 39-10-6582-943
Telefax 39-10-6582-941

GERMANY

Graefstrasse 97
D-60487 Frankfurt Main
Germany
Telephone 49-69-799-0
Telefax 49-69-799-2406