

SH On-line Liquid Concentration Sensor



Size



Weight≈3750g

MSDR-SH90-FB

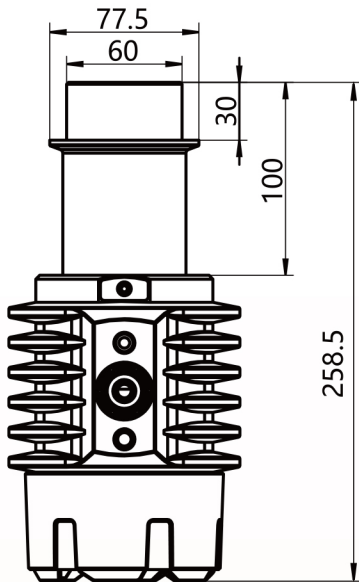

Panel



Detection Window



Measuring principle

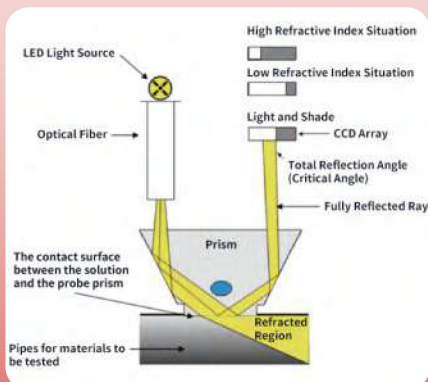

Product Introduction

It is the explosion-proof type of SH90 series products Explosion-proof grade :Ex ia II C T4 Ga Suitable for chemical, pharmaceutical and other dangerous industries

Product Parameter

Measure Range	Brix 0.00-90.00%	Resolution Ratio	Brix 0.01%
	RI 1.33299-1.51782		RI 0.00001
	Temperature -20°C~100°C		Temperature 0.1°C
Measurement Accuracy	Brix ±0.20%	Environment Temperature	0.0~ 60.0°C
	RI ±0.00030	Sample Volume	Submerged Measurement
	Temperature ±0.5°C	Withstand Pressure	1MPa
Measuring Time	Measure once in 1 seconds default	Protection Grade	Measuring Part IP67
Installation	Thread, flange, chuck, etc. Support customization.		
Output	Analogue Output: 4~20mA correspond to brix concentration 0.00-90.00% (Support Customization)		
	Digital Output: RS485		
	Other output options can be customized.		
Input	DC+24V±10% The current<100mA		