

# SH On-line Liquid Concentration Sensor



Size



Weight  $\approx$  882g

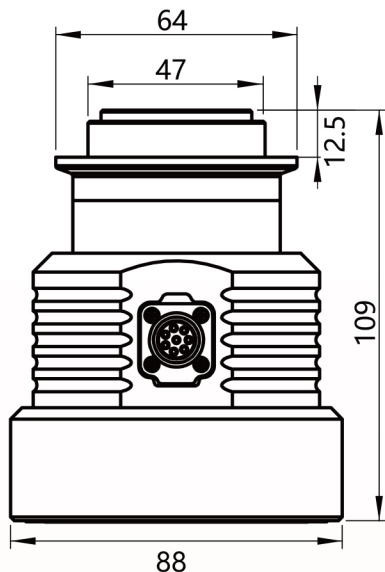

## MSDR-SH90



Panel



### Product Introduction

SH90-flat top series products are new on-line concentration sensor products created by Linghang Lijia, which has the characteristics of high measurement accuracy and wide measurement range.

Detection Window



### Product Parameter

Measuring principle

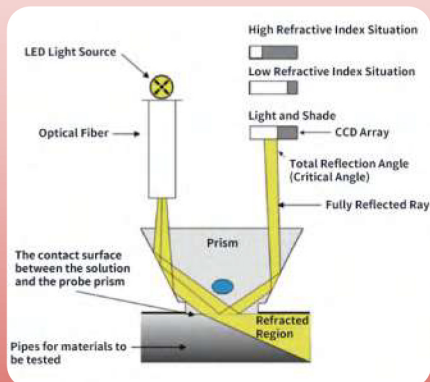

Measure Range	Brix 0.00-90.00%	Resolution Ratio	Brix 0.01%
	RI 1.33299-1.51782		RI 0.00001
	Temperature -20°C~100°C		Temperature 0.1°C
Measurement Accuracy	Brix $\pm$ 0.20%	Environment Temperature	0.0~ 60.0°C
	RI $\pm$ 0.00030	Sample Volume	Submerged Measurement
Measuring Time	Temperature $\pm$ 0.5°C	Withstand Pressure	1MPa
	Measure once in 1 seconds default	Protection Grade	Measuring Part IP67
Installation	Thread, flange, chuck, etc. Support customization.		
Output	Analogue Output: 4~20mA correspond to brix concentration 0.00-90.00% (Support Customization)		
	Digital Output: RS485		
Input	Other output options can be customized.		
	DC+24V $\pm$ 10% The current<100mA		