

FEATURES

- 100 meters long distance stable transmission, optional POE power supply;
- Compatible with VISION standard, drive-free drive directly support Halcon, VisionPro and other software;
- Support external trigger and flash synchronization, up to 7 GPIO, all photoelectric isolation;
- Support for 16bit grayscale and 48bit color lossless format output ;
- Support multiple cameras work at the same time, the number is not limited, can be any networking ;
- Unique packet retransmission technology to ensure reliable data transmission;
- Excellent SDK design, as simple as using a USB camera, plug and play;
- The SDK supports Windows, Linux, and Mac OS systems.



SPECIFICATIONS

Model parameter	MV-D200C-GE	MV-D200M-GE
Sensor	1/1.8" CCD, SHARP	
Shutter	Global	
Mono/Color	Color	Mono
Pixel siz	4.4X4.4 μm	
Effective Pixels	2MP	
Frame rate(fps)	1600X1200@27FPS	
Bit depth	12bit	
Sensitivity	1100mV 1/30s	1650mV 1/30s
GPIO	1 optical input, 1 optical output; 3 input 4 output	
Capture Mode	Continuous / software trigger / hardware trigger	
Gain	32	
Exposure time range (ms)	0.0002~36923	
Filter	Standard with a 650nm infrared cutoff filter	Standard double-sided AR penetration lens
Image Buffer	32M Bytes	
User-defined data area	2K Bytes	
Video output format	Bayer8/Bayer12	Mono8/Mono12
Visual Standards Protocol	GigE Vision V1.2、GenICam	
Lens Mount	C-mount is default, optional C or CS mount, M12 lens adapter accessories available	
Data interface	RJ 45 Gigabit Ethernet interface, downward compatible with 100M network system	
Power Supply	9~24V(POE is optional)	
Power Consumption	<2.5W	
Dimensions	29(mm)X29(mm)X40(mm) (excluding lens base and rear housing ports)	
Weight	<75g	
Temperature	Storage temperature:-30° C~ +60° C; Operation temperature:0° C~+50° C	
Other functions	Support arbitrary size ROI custom resolution, contrast and gamma adjustment, saturation adjustment, white balance correction, black level correction, custom dead point coordinate correction, ISP image processing acceleration, 3D noise reduction, custom LUT table, frame rate adjustment, custom camera name, etc.	

Spectrogram

MV-D200C-GE

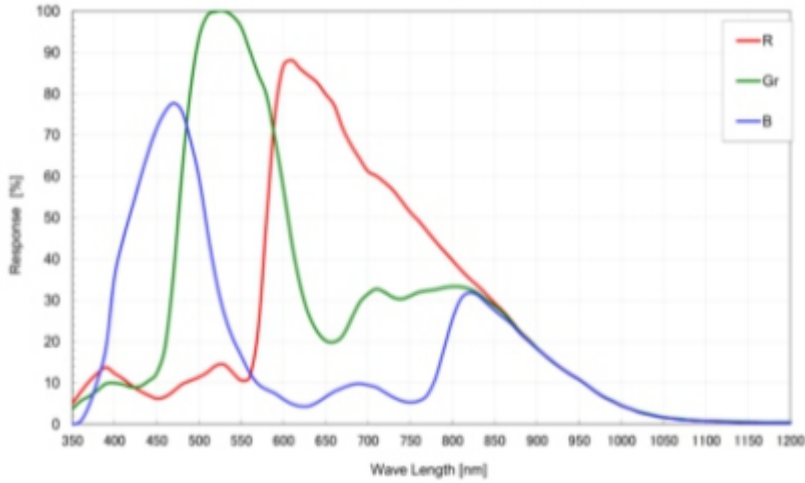

MV-D200M-GE

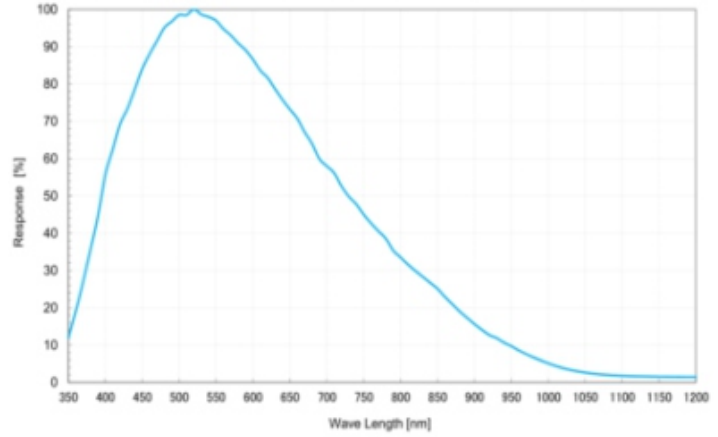

Dimensions

Unit: mm

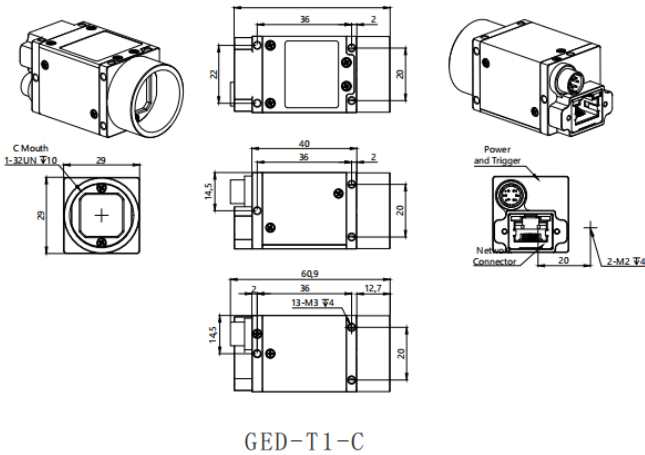

GED-T1-C

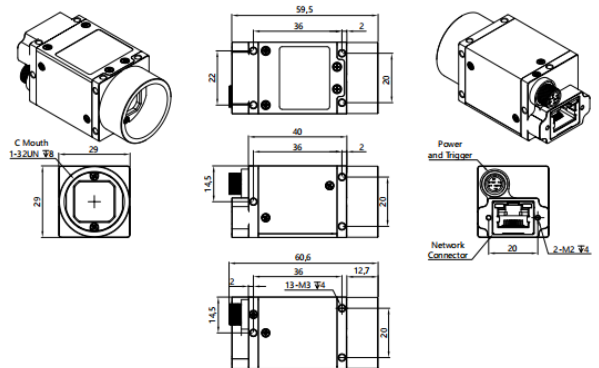

GED-T-CL

GE/GEF/GED/GEC Camera tail selection table

function postfix	Defindigram of aviation head line sequence	POE power supply	Dual head extended IO	Shrapnel type Air head interface	Threaded type Air head interface	Lens interface C-mount	Lens interface CS-mount	Status
-T-CL	1				●	●		recommend
-T-L	1				●		●	subscribe
-TPO-CL	2	●	●		●	●		subscribe
-T1-C	3			●		●		recommend
-TIP-C	3	●		●		●		subscribe
-T	4			●			●	Plan to stop production
-TPO	5	●	●	●			●	Plan to stop production
-TPO-C	5	●	●	●		●		Plan to stop production

Line order definition 1

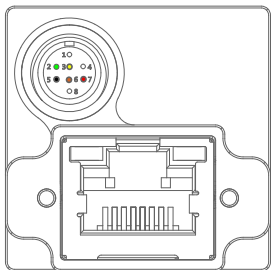

Port	Pin	Line color	Signal name	Signal instructions	Remark
Port A	1	white	GPI1+/TRIG_IN+	GPI1 Positive end / trigger input positive end	The default is the trigger input
	2	green	GP01+/STRB_OUT +	GP01 Positive end / Flash output positive end	The default is the flash output
	3	yellow	GP01-/STRB_OUT-	GP01 Negative end / flash output negative end	The default is the flash output
	4	empty feet			
	5	black	PWRGND	Camera power supply input minus terminal	
	6	brown (High soft blue)	GPI1-/TRIG_IN-	GPI1 Negative end / trigger input negative end	The default is the trigger input
	7	red	PWR12V	Camera power supply input positive end	
	8	empty feet			

Line order definition 2

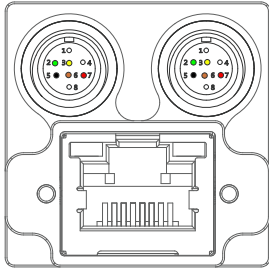

Port	Pin	Line color	Signal name	Signal instructions	Remark
Port A	1	white	GPI1+/TRIG_IN+	GPI1 Positive end / trigger input positive end	The default is the trigger input
	2	green	GP01+/STRB_OUT +	GP01 Positive end / Flash output positive end	The default is the trigger input
	3	yellow	GP01-/STRB_OUT-	GP01 Negative end / flash output negative end	The default is the trigger input
	4	empty feet			
	5	black	PWRGND	Camera power supply input minus terminal	
	6	brown (High soft blue)	GPI1-/TRIG_IN-	GPI1 Negative end / trigger input negative end	The default is the trigger input
	7	red	PWR12V	Camera power supply input positive end	
	8	empty feet			
Port B	1	white	GP04+	GP04Positive end output	
	2	green	GP02+	GP02Positive end output	
	3	yellow	GP03+	GP03Positive end output	
	4	empty feet			
	5	black	GPIO_COM	GPIOPublic minus end	
	6	brown	GPI2+	GPI2Positive end input	
	7	red	GPI3+	GPI3Positive end input	
	8	empty feet			

Line order definition 3

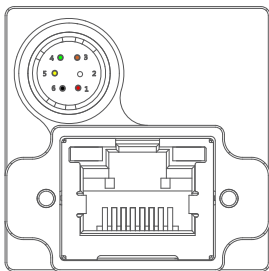

Port	Pin	Line color	Signal name	Signal instructions	Remark
Port A	1	red	PWR12V	Camera power supply input positive end	
	2	white	GPI1+/TRIG_IN+	GPI1Positive end / trigger input positive end	The default is the trigger input
	3	brown	GP02+	GP02output the positive end	empty feet
	4	green	GP01+/STRB_OUT+	GP01Positive end / Flash output positive end	The default is the flash output
	5	yellow	GP01-/STRB_OUT- /TRIG_IN-	GP01minus / flash output minus / trigger input minus	GPIOPublic minus end
	6	black	PWRGND	Camera power supply input minus terminal	

Line order definition 4

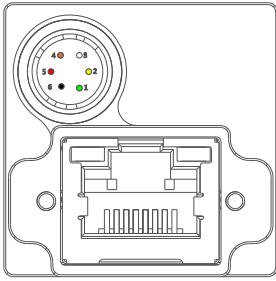

Port	Pin	Line color	Signal name	Signal instructions	Remark
Port A	1	green	GP01+/STRB_OUT+	GP01Positive end / Flash output positive end	The default is the flash output
	2	yellow	GP01-/STRB_OUT-	GP01Negative end / flash output negative end	The default is the flash output
	3	white	GPI1+/TRIG_IN+	GPI1Positive end / trigger input positive end	The default is the trigger input
	4	brown	GPI1-/TRIG_IN-	GPI1Negative end / trigger input negative end	The default is the trigger input
	5	red	PWR12V	Camera power supply input positive end	
	6	black	PWRGND	Camera power supply input minus terminal	

Line order definition 5

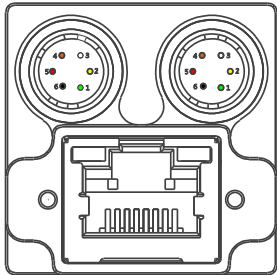

Port	Pin	Line color	Signal name	Signal instructions	Remark
Port A	1	green	GP01+/STRB_OUT+	GP01Positive end / Flash output positive end	The default is the flash output
	2	yellow	GP01-/STRB_OUT-	GP01Negative end / flash output negative end	The default is the flash output
	3	white	GPI1+/TRIG_IN+	GPI1Positive end / trigger input positive end	The default is the trigger input
	4	brown	GPI1-/TRIG_IN-	GPI1Negative end / trigger input negative end	The default is the trigger input
	5	red	PWR12V	Camera power supply input positive end	
	6	black	PWRGND	Camera power supply input minus terminal	
Port B	1	green	GP02+	GP02Positive end output	
	2	yellow	GP03+	GP03Positive end output	
	3	white	GP04+	GP04Positive end output	
	4	brown	GPI2+	GPI2Positive end input	
	5	red	GPI3+	GPI3Positive end input	
	6	black	GPIO_COM	GPIOPublic minus end	

C interface / CS interface camera diagram

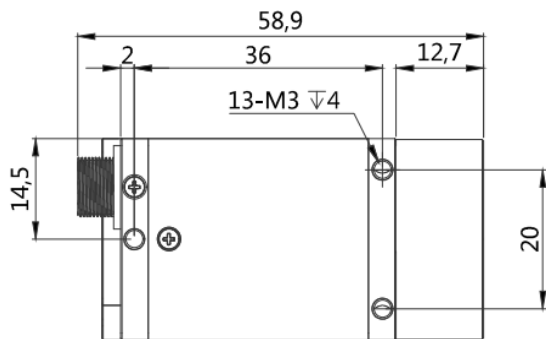

C interface

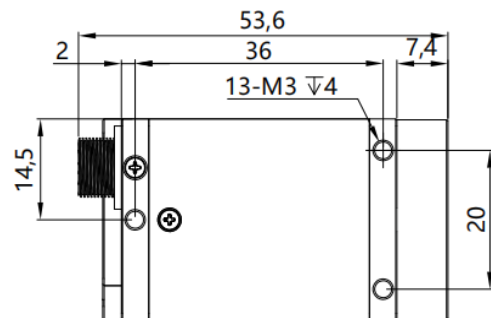

CS interface

Unit: mm