

FEATURES

- Embedded system integration is more convenient, higher integration.
- Support 8bit grayscale and 8bit color lossless format output.
- The camera comes with programmable IO, which supports external trigger flash synchronous photography.
- Support PCLinux system and ARMLinux system, can be integrated in embedded devices.
- Compatible with VISION protocol, seamlessly compatible with Halcon, VisionPro, Labview and other vision software.



SPECIFICATIONS

Parameter	Model	BL-134GC-GE	BL-134GM-GE
Sensor		1/2" CMOS	
Shutter		Global	
Color/Mono		Color	Mono
Pixel Size		4.8umx4.8um	
Resolution		1.3MP	
Frame rate		1280x1024@91.5FPS	
Output pixel width		10bit	
Sensitivity		7.3 V/lux-s@540nm	
GPIO		1 optical coupling isolated input, 2 optical coupling isolated output	
Maximum gain		16.5	
Exposure time(ms)		0.008~1048.6	
AD width		12bit	
Frame buffer		128MB	
Camera custom data		2KB	
Video output format		Bayer GB 8/12bit	Mono 8/12bit
SNR		41dB	
Visual standard protocol		GigE Vision V1.2, GenICam	
Lens mount		C / M12	
Data interface		GigE	
Power supply		12~24V	
Power		< 2.66W	
Dimensions		43x43x28.7mm (excluding lens base and rear shell interface)	
Weight		< 75g	
Temperature		Working temperature:0~50° Storage temperature:-30~60°	
Operating system		WINXP, WIN7/8/10 32-bit & 64-bit systems, Linux and ARM Linux drivers, Android platform drivers, MAC OS systems	
Drivers		Directshow component Halcon Dedicated Component Labview Dedicated Driver OCX Component TWAIN component	
Programming language package		C/C++/C#/VB6/VB.NET/Delphi/BCB/Python/Java	
Programming language package		Support arbitrary size ROI custom resolution, contrast and gamma adjustment, saturation adjustment, white balance correction, black level correction, custom dead point coordinate correction, ISP image processing acceleration, 3D noise reduction, custom LUT table, frame rate adjustment, custom camera name, and more	

SPECTROGRAMS

Quantum Efficiency

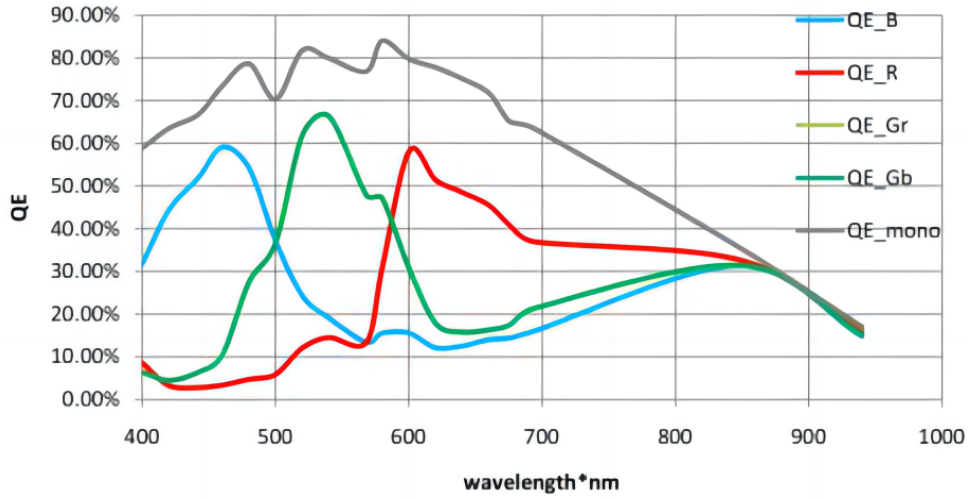

DIMENSIONS(Unit: mm)

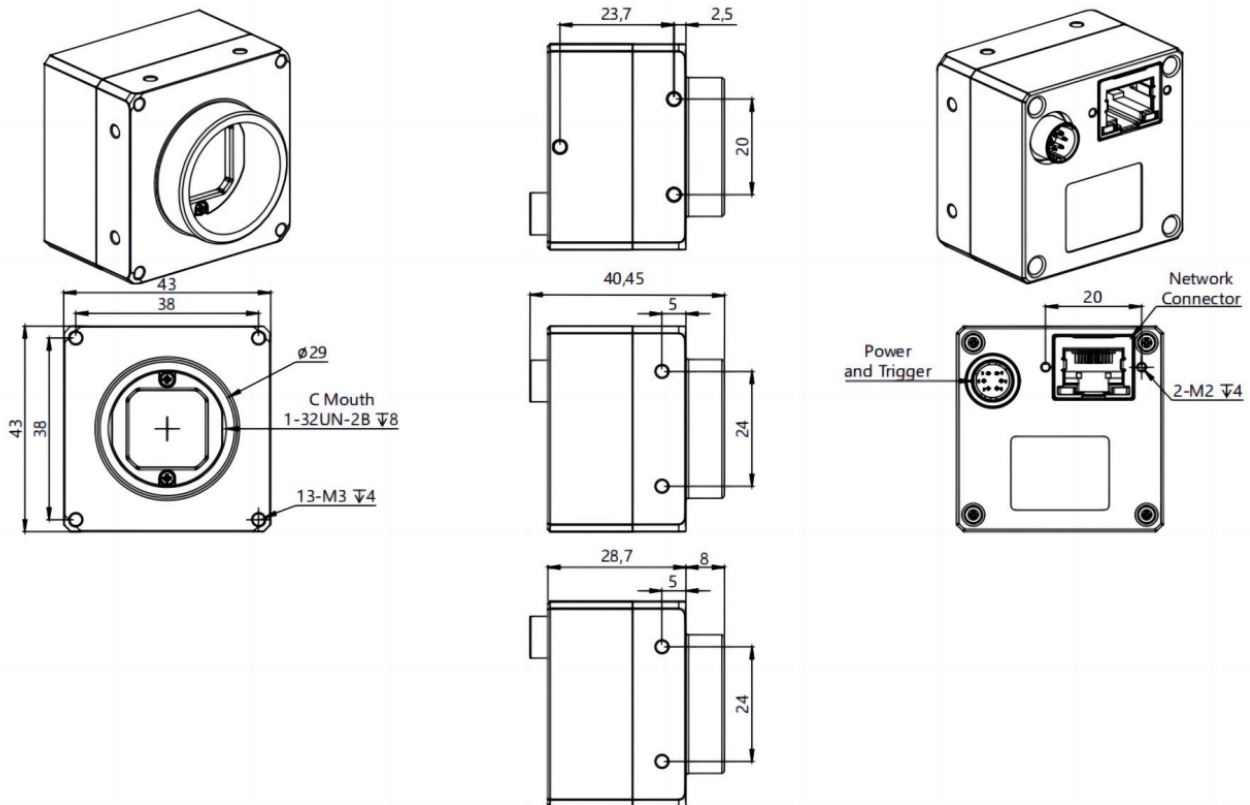

C - Interface

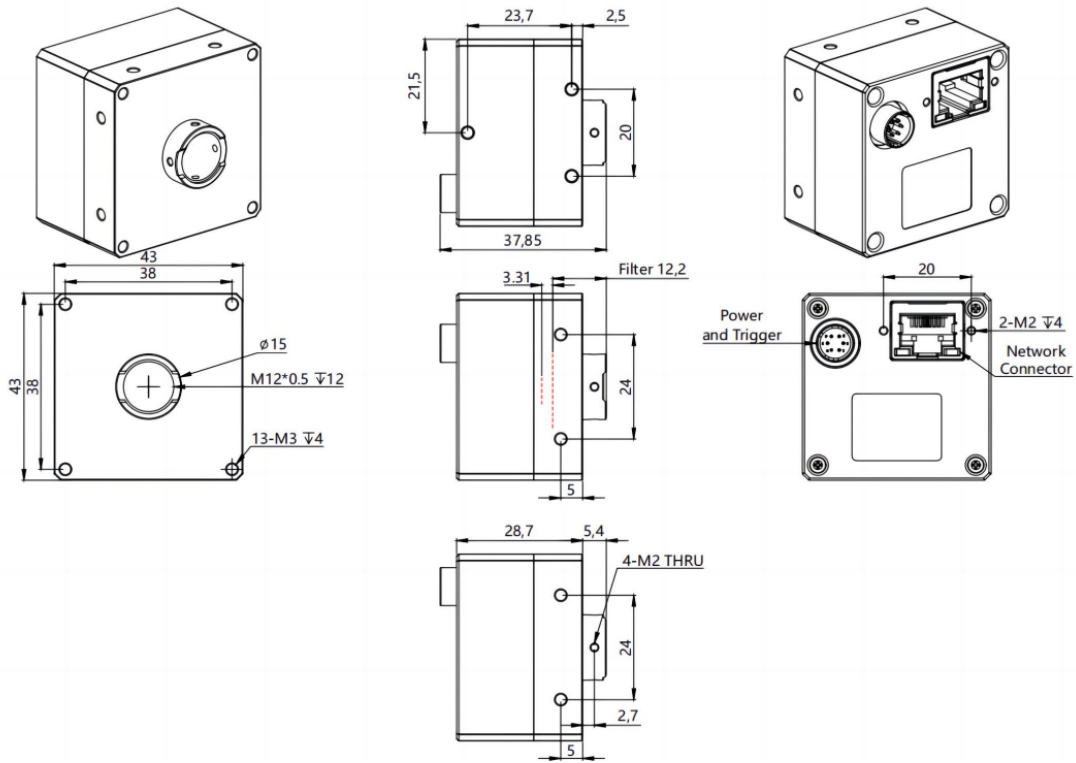

M - Interface

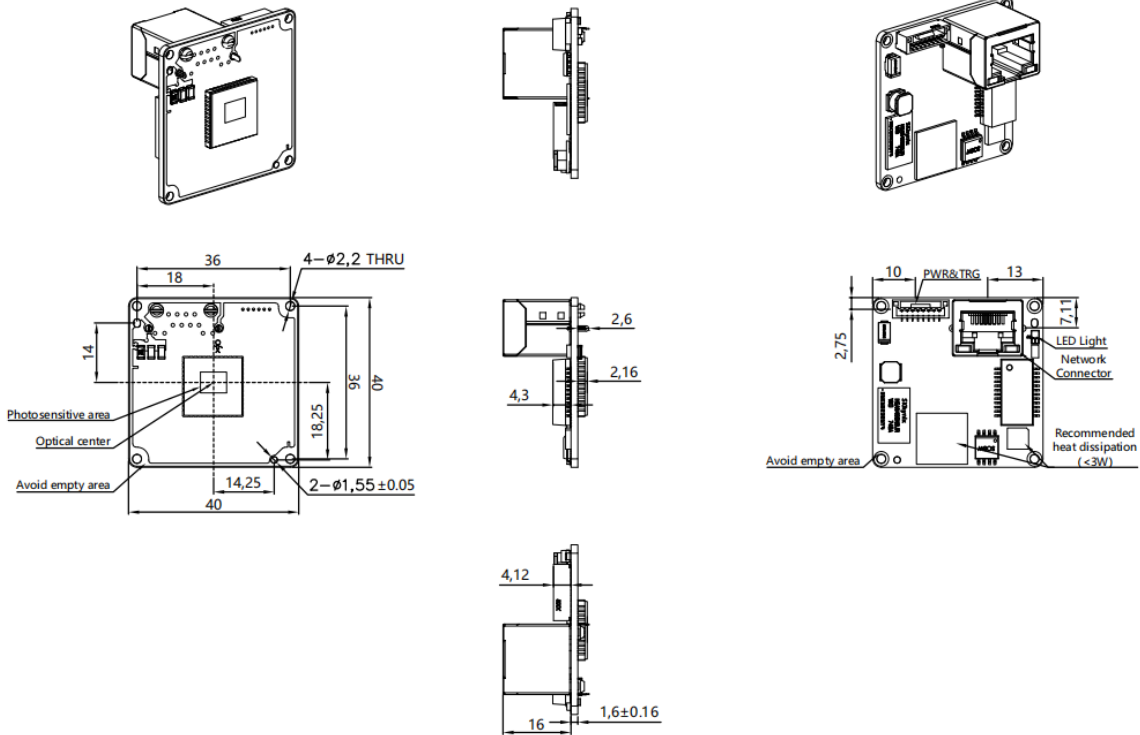

B - Interface

List of pin functions :

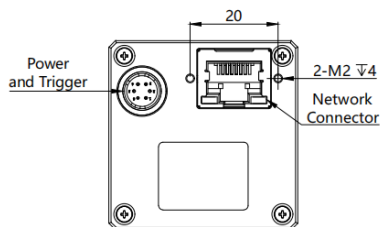

Port	Pin	Line Color	Signal Name	Signal Description	Remark
PortA	1	red	DC12V+	Camera power input positive end	
	2	white	GPI_1+/TRIG_IN+	GPI_1 Positive end/Trigger input positive end	Default to trigger input
	3	brown	GPO_2+	GPO_2 outputs the positive end	Empty foot
	4	green	GPO_1+/STRB_OUT+	GPO_1 Positive/Flash output positive end	Default to flash output
	5	yellow	GPO_1+/STRB_OUT- /TRIG_IN-	GPO1 Negative end/flash output negative end / Trigger input negative end	IO_COM public negative terminal
	6	black	GND	Camera power input negative end	