

DCM2.0-4C003W-5PS

Machine vision light controller operating instructions

Content

1. Controller Classification and Naming	1
2. Specifications	2
3. Main Fuctions	3
4. Instructions and Operations	4
5. Outline and Dimensions	12
Accessory List	13

1. Controller Classification and Naming

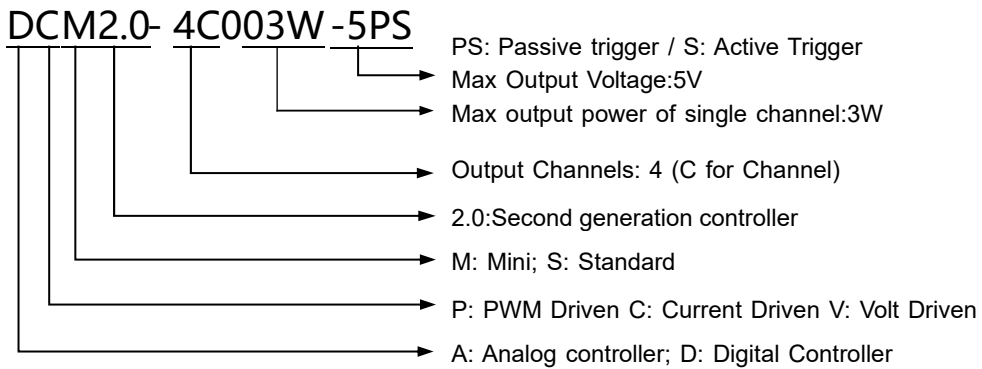

Input Voltage of Standard Controller: AC 100~220V

Input Voltage of Mini Controller: DC 24V

PS (Passive trigger): Input level signal to the controller trigger channel from outside for external trigger control.

S (Active Trigger): Externally trigger the channel switch to ON / OFF (open circuit or short circuit triggers the channel pins).

2. Specifications

Features	Values	Description
Control Mode	constant current	/
Input Voltage	DC24V	/
Output voltage	DC5V	/
Input power	≥20W	The minimum input power depends on the maximum power of the load
Channels	4	/
Manual Control	yes	Adjusted by pressing the key
Remote Control	yes	Adjusted by upper computer software
Brightness Level Memory	yes	Automatic memory starts in 8s after adjustment
RS232 Baud rate	9600	/
Adjustable Brightness Level	255 levels	Long Press for rough adjustment; Short Press for subtle adjustment; Upper computer software control is available.
Maximum output power of single channel	3 W	/
External triggering mode	Passive trigger	Valid trigger voltage range: DC 5-24V
External trigger delay time	H, ON→OFF <60us	H: high level trigger; L: low level trigger; ON and OFF represent the on and off state of LED light.
	H, OFF→ON <60us	
	L, ON→OFF <60us	
	L, OFF→ON <60us	
External trigger frequency	<1/T	Determined by light flashing frequency, if T= 1ms, the maximum external trigger frequency is 1KHz.
Working condition	Temp: -10~50°C	/
	Humidity: 20~80%	/
Standby power	<1W	/
Product dimension	128* 60* 158mm	L * W * H
Weight	0.7kg	/

3. Main Functions

◆ Manually Control Brightness Levels

Channel switching is performed via the "CH" button on the panel. Pressing the "▼" or "▲" button to decrease or increase the brightness level.

◆ Remotely Control Brightness Levels

RS232 communication port connects the controller to upper computer. On the upper computer, the brightness levels of each channel can be easily set, and the present brightness levels can also be read and displayed. At the same time, the ON/OFF button of the application on the computer can be used to turn on/off the light.

◆ Brightness Level Memory

8 seconds after adjusting the brightness level of each channel with the keys on controller panel or upper computer application, the controller automatically starts to record the brightness level of each channel, and the record will not be lost even when power failure happens.

4. Instructions and Operations:

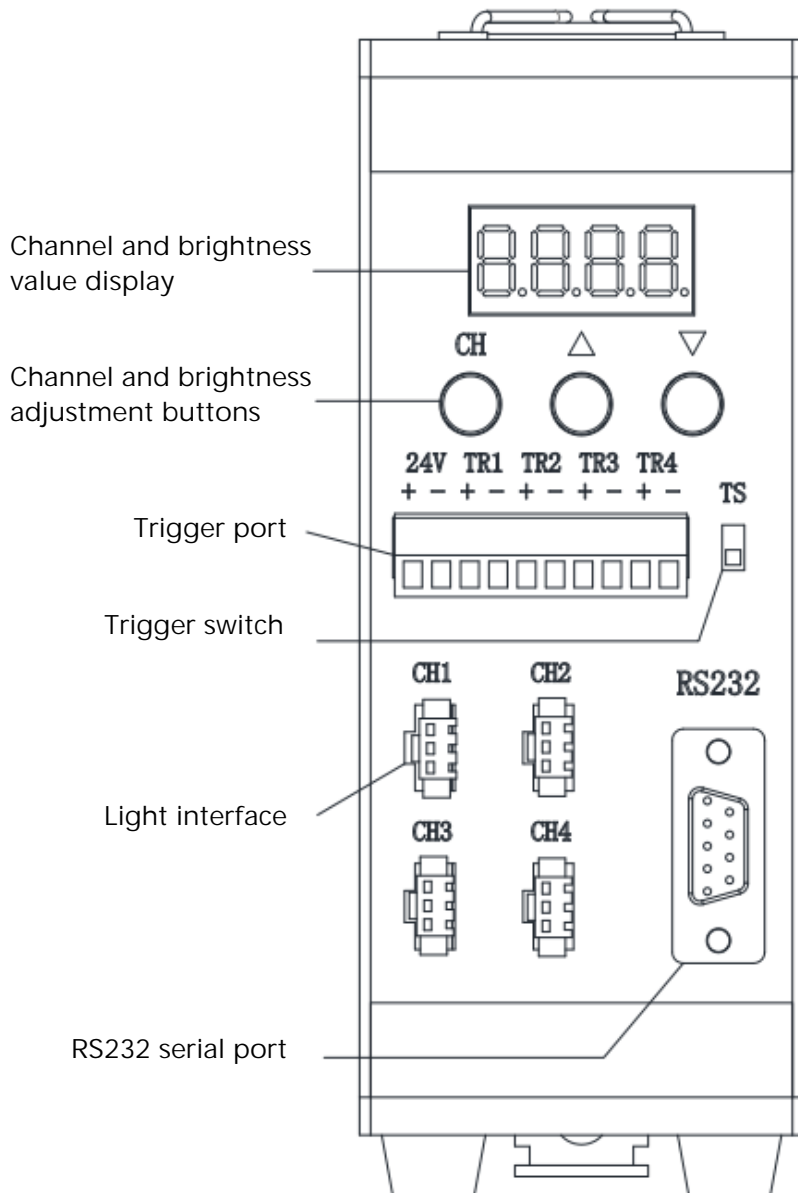

The display adopts a four-in-one digital tube, the first digit indicates the channel number, which can be cut by pressing the "CH" button change the channel number to be set; The last three digits indicate the brightness level of the corresponding channel. The display range is 000-255 (decimal) .

4.1 Controller terminal definition

The definition of the connection terminal, refer to the screen printing marked on the panel:

- T4V+, 24V- : DC24V input power supply positive, ground.
- "TS" : Trigger mode switch. When the light is in constant ON mode the switch is on TS side, the light will be turned off as the high level triggers and gives a signal; If switched to the other side, and the light is in trigger mode (OFF state), the light will be turned on when t the high level triggers and gives a signa.

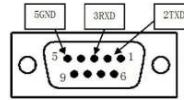

- RS232: Serial communication interface.
- TR1+, TR2+ , TR3+ and TR4+ : CH1 , CH2 , CH3 and CH4 trigger signal line interfaces, respectively.
- TR1-, TR2- ,TR3- and TR4- : internal connection, common terminal of trigger signal line.

The polarity of the common end is different, and the wiring method is different. The wiring diagram is as follows:

Trigger interface internal wiring diagram:

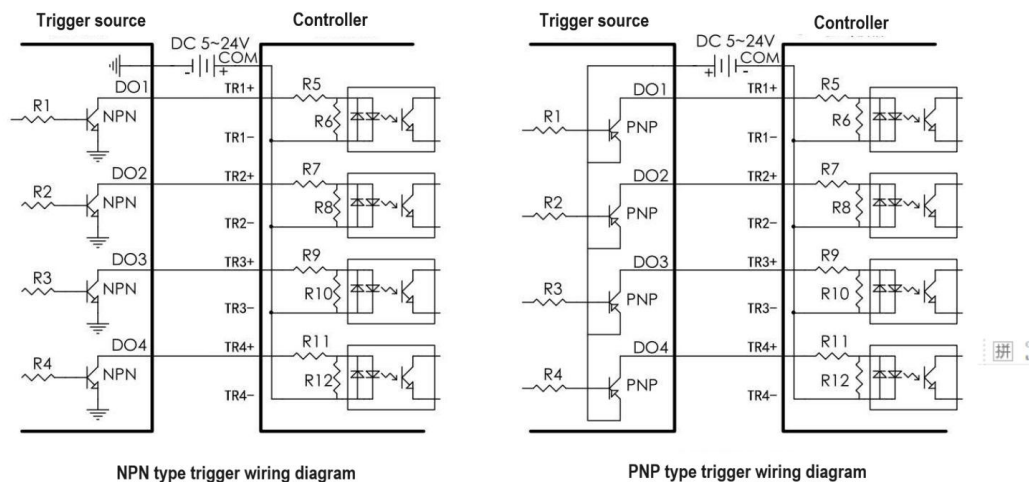

➤ 4.2 Manual Operation

- "CH" : Channel switching button.
- "▼" : To decrease the brightness level, 000 stands for the lowest level.
- "▲" : To increase the brightness level, 255 stands for the highest level.

The "CH" button is for switching different channels. Each time you press it, the digital displaying number will be automatically increased by 1. (if the present number is 2, the displaying number will return to 1 when pressing the CH button again).

After selecting a channel, the brightness level of the channel can be adjusted continuously (decrease or increase) by short pressing the "▼" or "▲" button. If long pressing the "▼" or "▲" button, the brightness level of the channel will be roughly changed (10 brightness levels each long press).

The controller has brightness memory function and the memory is saved for power failure. It automatically starts to record in 8S after each brightness adjustment. Every time when you recharge the controller, it displays the last channel number and the brightness level when power off.

4.3 Remote Operations

- (1). Open the executable file "4 channel light source control program V2.0.exe", and the following interface pops up:



(2). Interface Introduction

◆ Communication status bar

- COM: Selecting COM port for the controller connection.
- State : Communication status bar, showing whether the controller is successfully connected to the computer.

Failed: connection failed.

Succeed: connection succeed.

◆ **Brightness control bar**

- Channel X (X=1, 2, 3, 4) : Indicating the controlled channel number
- 0-255: brightness level adjustment range, the brightness level can be adjusted by dragging the slider.

- ◆ Communication information: Display the control instructions sent by the host computer to the controller, and the corresponding return received value.

◆ **4.4 Communication Protocol**

Hardware Specifications

Baud Rate	Byte Length	Stop Bit	Parity Check
9600 bps	8 bits	1 bit	/

Data format (frame format)

1 Bit	1 Bit	1 Bit	3 Bit	2 Bit
Particular character	Command character	Channel character	Data	XOR/AND Check word

PS: All communication bytes are in ASCII code

- ◆ Particular character = \$
- ◆ Command character = 1, 2, 3, 4.

Definition:

- 1: Turn on the corresponding channel
- 2: Turn off the corresponding channel
- 3: Set parameters of the corresponding channel brightness
- 4: Read parameters of the corresponding channel brightness

When the command character is 1, 2 or 3, if the controller receives the command successfully, a particular character \$ will be returned; While failed, & will be returned.

When the command character is 4, if the controller receives the command successfully, the brightness setting parameters of the corresponding channel will be returned (the return format is the same as the sent format); While failed, & will be returned.

- ◆ **Channel Character 1, 2, 3, 4 represent 1 to 4 channels.**
- ◆ **Value = 0XX (XX = any value within 00 to FF), corresponding to the setting parameter of the channel power supply, with the high bit ahead and the low bit after.**
- ◆ **XOR/AND Check word = the XOR checksum of the characters excluded particular characters, command characters, channel character and number. With the ASCII code of the higher half-byte of the checksum preceding and the ASCII code of the lower half-byte following.**
- ◆ **E.g. Set the 1st channel brightness to 100, then write "\$3106414" in ASCII code down:**

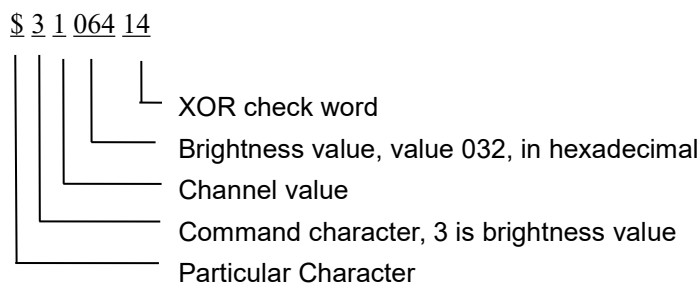

The procedure of the XOR check word algorithm is as follows:

	String		ASCII Code	ASCII code in hexadecimal		Higher half-byte and Lower half-byte data in 8421 code	
Particular Character	\$		36		24		0010 0100
Command Character	3	→	51	→	33	→	0011 0011
Channel Character	1		49		31		0011 0001
Value	0		48		30		0011 0000
	6		54		36		0011 0110
	4		52		34		0011 0100
XOR AND							0001 0100
XOR Check Word							1 4

PS: During turning on/off the corresponding channel power and reading out the 3 functions of XOR check word algorithm of the channel power parameters, the 3 bytes of the value has no effect on the XOR results, and it is fine if the format remains 0XX (XX=any value within 00 to FF).

The following forms are different sets of experimental data, if users write their own Demo program, they can refer to the following data for comparison test.

2nd channel OFF: \$220291f

	String		ASCII Code	ASCII code in hexadecimal		Higher half-byte and Lower half-byte data in 8421 code	
Particular Character	\$		36		24		0010 0100
Command Character	2	→	50	→	32	→	0011 0010
Channel Character	2		50		32		0011 0010
Value	0		48		30		0011 0000
	2		50		32		0011 0010
	9		57		39		0011 1001
XOR AND							0001 1111
XOR Check Word							1 f

3rd channel ON: \$1306414

	String		ASCII Code	ASCII code in hexadecimal		Higher half-byte and Lower half-byte data in 8421 code	
Particular Character	\$		36		24		0010 0100
Command Character	1	→	49	→	31	→	0011 0001
Channel Character	3		51		33		0011 0011
Value	0		48		30		0011 0000
	6		54		36		0011 0110
	4		52		34		0011 0100
XOR AND							0001 0100
XOR Check Word							1 4

Reading 2nd channel power parameters: \$4206410

	String		ASCII Code	ASCII code in hexadecimal		Higher half-byte and Lower half-byte data in 8421 code	
Particular Character	\$		36		24		0010 0100
Command Character	4	→	52	→	34	→	0011 0100
Channel Character	2		50		32		0011 0010
Value	0		48		30		0011 0000
	6		54		36		0011 0110
	4		52		34		0011 0100
XOR AND							0001 0000
XOR Check Word							1 0

5. Outline and Dimensions

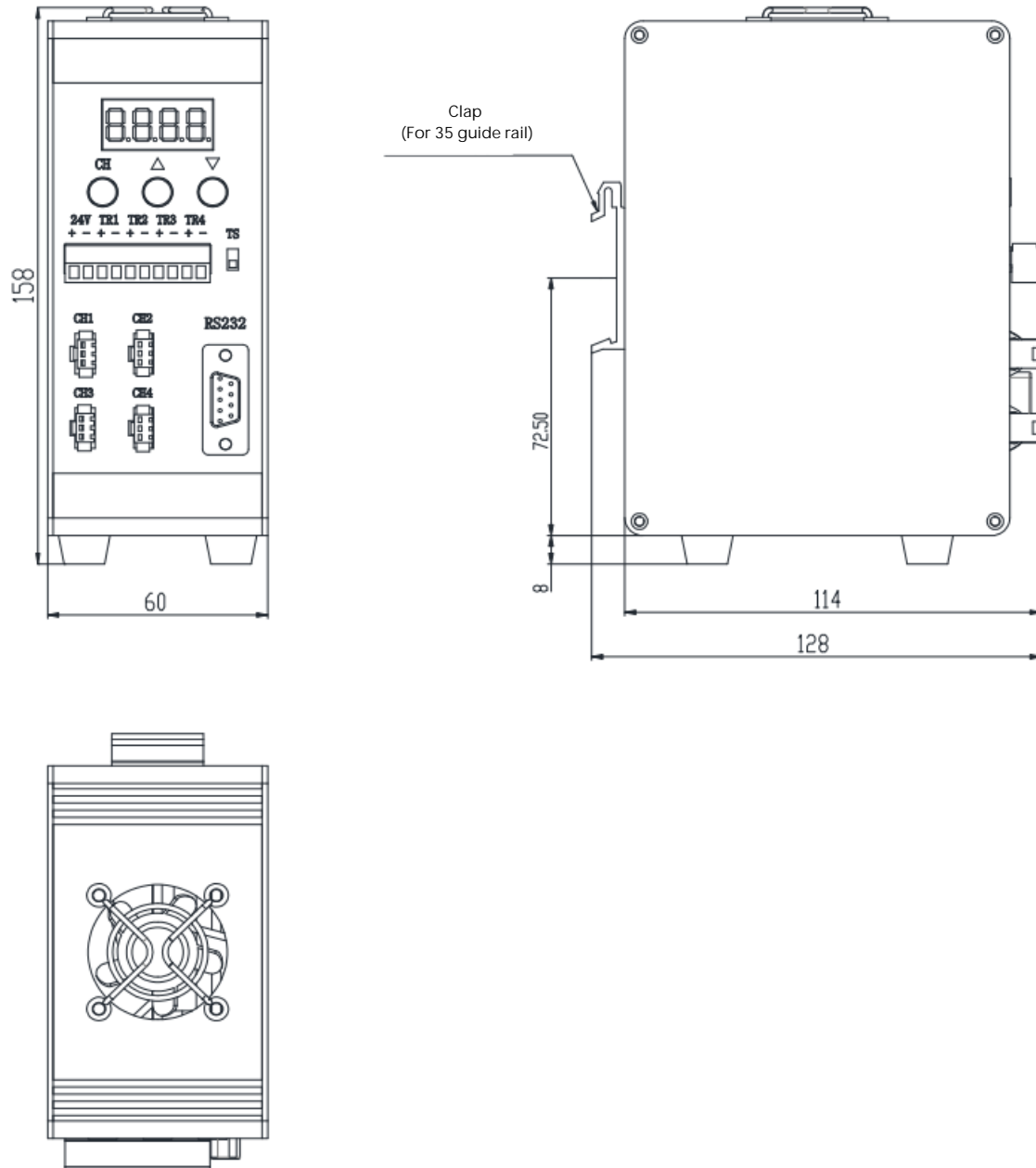

Accessory List

Item	Quantity (unit)	Remark
DCM2.0-4C003W-5PS Controller	1	
RS232 Serial port line	1	
10PIN Green terminal male plug	1	