



## WUXI HONGBEI BAKEWARE CO., LTD.

🏠 7 Yuansheng Street, Xishan District, Wuxi CN 214107

☎ +86-0510-82831000

✉ info@wxhongbei.com

🌐 www.wxhongbei.com



Official Website



Bakeware Catalogue

# HONGBEI

*Industrial Bakeware  
Manufacturer*



**2026**

# ABOUT US

Since the establishment of Baide Precision in 2011, we have specialized in metal precision machining, providing high-quality, customized solutions for clients worldwide. With the growing demand for baking tool manufacturing services and Wuxi's strategic position as a core hub of China's baking tool industry, we launched a dedicated baking tool manufacturing factory in 2021. Wuxi Hongbei Bakeware Co., Ltd. Leveraging Wuxi's well-developed supply chain ecosystem and over a decade of precision machining expertise, we offer end-to-end customization services, from design drafting to prototype development. Our product range includes, but is not limited to, flat baking trays, French bread pans, hamburger bun pans, and multi-cavity cake molds. To date, we have successfully served clients from over 30 countries worldwide. In addition, our experienced international sales team possesses in-depth industry knowledge and a strong understanding of global markets, enabling us to quickly grasp client needs and deliver tailored solutions. From production to delivery, we are committed to creating an efficient and premium collaboration experience for our clients.

Wuxi Hongbei – Your trusted partner in baking tool manufacturing.

## Core Business

<p><b>Mold Development &amp; Process Support</b></p> <ul style="list-style-type: none"> <li>Precision Mold Manufacturing 15 years CNC machining experience, <math>\pm 0.01</math>mm tolerance control</li> <li>3 complimentary design modifications</li> <li>Customized Solutions Material selection support (Aluminum alloy/ Stainless steel/ Aluminized steel)</li> <li>Structural durability enhancement solutions</li> </ul>	<p><b>Quality Control &amp; Certifications</b></p> <ul style="list-style-type: none"> <li>Three-stage Inspection Process: Raw material composition testing (with SGS reports)</li> <li>In-process monitoring (weld strength/coating thickness)</li> <li>Finished product performance testing (Non-stick properties/Abrasion resistance/Hardness)</li> <li>Certifications: <b>ISO 9001:2015 Quality Management System</b> <b>FDA 21 CFR &amp; LFGB Sections 30/31 Food Contact Safety Certification</b></li> </ul>
<p><b>Flexible Production Capabilities</b></p> <ul style="list-style-type: none"> <li>Order Response Time: Production scheduling confirmation within <b>24 hours</b></li> <li>Prototype orders: <b>50-piece MOQ</b> (Standard lead time: <b>3-7 days</b>)</li> <li>Bulk orders: <b>50,000 pieces/month</b> capacity (Requires 30-day advance scheduling)</li> </ul>	<p><b>Supply Chain Management</b></p> <ul style="list-style-type: none"> <li>Component Integration: <b>100+ cooperative suppliers</b></li> <li>Export Services: Professional customs brokerage team (Documentation preparation included)</li> </ul>
<p><b>After-Sales Service</b></p> <ul style="list-style-type: none"> <li>Technical Response: Issue acknowledgment within 2 hours (<b>Mon-Fri 9:00-18:00 GMT+8</b>)</li> <li>Warranty Terms: 1-year warranty on core components (Refer to Warranty Agreement)</li> </ul>	

## Certifications & Qualifications



## Authorized Testing Certification



# Custom Manufacturing Process

Drawing & Production  
assessment

Mould & Sample making

Mass production

Packaging & Delivery



Requests received

Final drawing confirming

Sample confirming

Inspection

## Mold Development Support



## Designing and Drawing Making

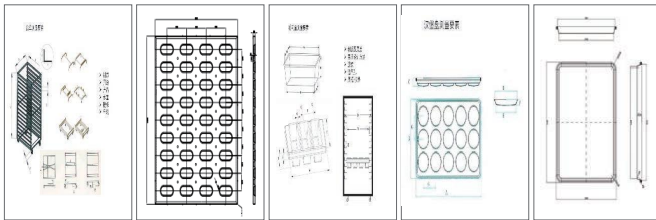

We provide professional packaging customization services tailored to your needs, offering comprehensive support from material selection to design and printing. By utilizing eco-friendly materials, creative designs, and high-precision printing, we craft a unique visual identity for your brand, ensuring your products stand out in the market.

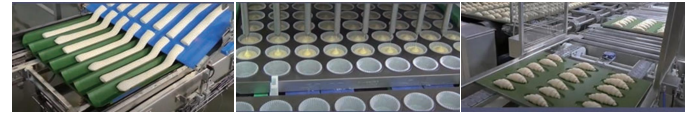



<b>HONGBEI</b> Deep Drawn Baking Tray	<b>01-06</b>
<b>HONGBEI</b> Handmade Baking Tray	<b>07-11</b>
<b>HONGBEI</b> Hamburger Bun Pan	<b>12-19</b>
<b>HONGBEI</b> Baguette Baking Tray	<b>20-25</b>
<b>HONGBEI</b> Loaf Pan	<b>26-31</b>
<b>HONGBEI</b> Muffin Tray	<b>32-35</b>
<b>HONGBEI</b> Silicone Baking Mold	<b>36-39</b>
<b>HONGBEI</b> Baking Trolley	<b>40-47</b>
Pan Use & Care	<b>48-49</b>

# HONGBEI Baking Tray



**Alu.Alloy Sheet Pan**

CODE	SIZE	MAT.	COAT.
HBA6364	615 × 535 × 30mm	Al Alloy 2,0mm	Anod.

# Customized Sheet Pan

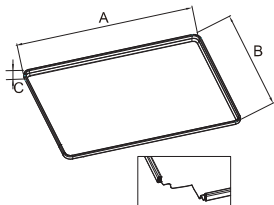

With only a few specifications we can manufacture your customized products

- A. Overall / Topin/ Bottomin Length
- B. Overall / Topin/ Bottomin Width
- C. Height

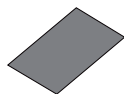

Flat (no edge)

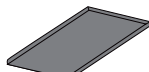

One Side Open

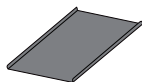

U Style

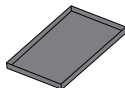

Four Sides

Material: Alu. Alloy  Alu. Steel  Others  Thickness \_\_\_\_\_

## Manufacture Craft:

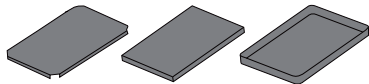

Open Corner  Welded  Deep Drawn

## Corrugated:

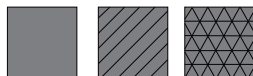

Plain  Wavy  Comby

## Edge Design:



No Edge  Folded  Round Wire  Square Band  Downward Folded

## Side Angle:



Straight  Oblique

## Perforation::



Non-perforated

Round holes

Special holes



## HONGBEI Deep Drawn Baking Tray

*Seamless Structure for Hygiene and Easy Cleaning*

*High Strength and Excellent Durability*

*Uniform Heat Distribution*

*Smooth and Elegant Appearance*

*Fully Customizable*

*Long Service Life and Cost Efficiency*



### Alu.Alloy Sheet Pan

Edge reinforced with galvanized strip

CODE	SIZE	MAT.	COAT.
HBA5794	330 × 230 × 25mm	Al Alloy 1,0mm	Plain
HBA5793	460 × 330 × 25mm	Al Alloy 1,0mm	Plain
HBA5792	600 × 400 × 25mm	Al Alloy 1,0mm	Plain
HBA5791	660 × 460 × 27mm	Al Alloy 1,2mm	Plain
HBA4767	800 × 600 × 25mm	Al Alloy 1,0mm	Plain



### Alu.Alloy Perforated Sheet Pan

CODE	SIZE	MAT.	COAT.
HBA5795	600 × 400 × 25mm	Al Alloy 1,0mm	Plain
HBA5796	660 × 460 × 25mm	Al Alloy 1,0mm	Plain
HBA4768	800 × 600 × 28mm	Al Alloy 1,0mm	Plain



### Alu.Alloy Sheet Pan

CODE	SIZE	MAT.	COAT.
HBA5179	657 × 455 × 25,4mm	Al Alloy 1,5mm	Hard Anod.



### Alu.Alloy Sheet Pan

CODE	SIZE	MAT.	COAT.
HBA6290	660 × 460 × 30mm	Al Alloy 1,5mm	Plain



### Alu.Alloy Perforated Sheet Pan Non-stick

CODE	SIZE	MAT.	COAT.
HBA6008	600 × 400 × 20mm	Al Alloy 1,5mm	Teflon



### Alu.Alloy Sheet Pan

CODE	SIZE	MAT.	COAT.
HBA4748	600 × 400 × 20mm	Al Alloy 1,5mm	Anod.



### Alu.Alloy Perforated Sheet Pan Non-stick

CODE	SIZE	MAT.	COAT.
HBA6100	600 × 400 × 20mm	Al Alloy 1,5mm	Teflon

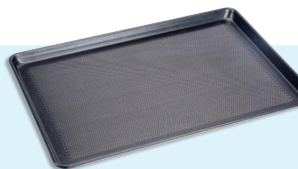

### Alu.Alloy Perforated Sheet Pan Non-stick

CODE	SIZE	MAT.	COAT.
HBA6354	600 × 400 × 30mm	Al Alloy 1,2mm	Teflon

## HONGBEI

### Deep Drawn Baking Tray



**AluSteel Sheet Pan Non-stick**

CODE	SIZE	MAT.	COAT.
HBA6353	600 × 400 × 20mm	AluSteel 0,7mm	Teflon



**Alu.Alloy Sheet Pan Non-stick**

CODE	SIZE	MAT.	COAT.
HBA6358	600 × 400 × 10mm	Al Alloy 1,5mm	Teflon



**Alu.Alloy Sheet Pan Non-stick**

CODE	SIZE	MAT.	COAT.
HBA6049	600 × 400 × 25mm	Al Alloy 1,2mm	Teflon

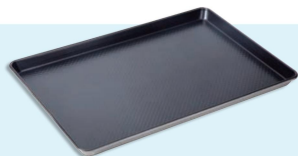

**AluSteel Corrugated Sheet Pan Non-stick**

CODE	SIZE	MAT.	COAT.
HBA5052	600 × 400 × 30mm	AluSteel 0,8mm	Teflon



## HONGBEI Handmade Baking Tray

*Highly Flexible and Customizable*

*Perfect for Small-Batch or Special Orders*

*Strong and Reinforced Structure*

*Cost-Effective Solution*

*Easy Maintenance and Repair*

*Available in Multiple Materials and Coatings*



**Edgeless Non-stick Flat Sheet Pan**

CODE	SIZE	MAT.	COAT.
HBA5615	1000 × 800 × 9,5mm	Al Alloy 1,5mm	Teflon
HBA5614	800 × 600 × 9,5mm	Al Alloy 1,5mm	Teflon

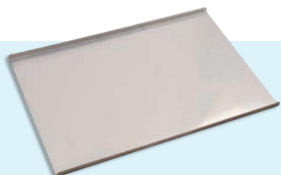

**U-shaped Sheet Pan**

CODE	SIZE	MAT.	COAT.
HBA5956	600 × 400 × 10mm	Al Alloy 2,0mm	Plain
HBA5771	700 × 500 × 10mm	Al Alloy 2,0mm	Plain



**U-shaped Non-stick Sheet Pan**

CODE	SIZE	MAT.	COAT.
HBA5676	700 × 450 × 20mm	AluSteel 1,2mm	Teflon
HBA3514	600 × 400 × 20mm	AluSteel 1,2mm	Teflon



**U-shaped Sheet Pan**

CODE	SIZE	MAT.	COAT.
HBA4204	800 × 600 × 20mm	AluSteel 1,5mm	Plain



**U-shaped Perforated Non-stick Sheet Pan**

CODE	SIZE	MAT.	COAT.
HBA4889	575 × 470 × 17mm	Al Alloy 2,0mm	Glaze silicone

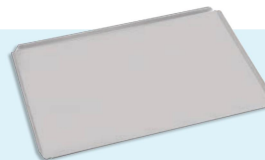

**Open-corner Flat Sheet Pan**

CODE	SIZE	MAT.	COAT.
HBA4863	650 × 530 × 10mm	Al Alloy 1,5mm	Plain



**Open-corner Non-stick Flat Sheet Pan**

CODE	SIZE	MAT.	COAT.
HBA5785	530 × 325 × 10mm	Al Alloy 1,2mm	Teflon
HBA5094	600 × 400 × 10mm	Al Alloy 1,2mm	Teflon



**Open-corner Perforated Flat Sheet Pan**

CODE	SIZE	MAT.	COAT.
HBA5787	530 × 325 × 10mm	Al Alloy 1,2mm	Plain



**Open-corner Perforated Non-stick Flat Sheet Pan**

CODE	SIZE	MAT.	COAT.
HBA5786	530 × 325 × 10mm	Al Alloy 1,2mm	Teflon
HBA5096	600 × 400 × 10mm	Al Alloy 1,2mm	Teflon
HBA4884	800 × 600 × 10mm	Al Alloy 1,5mm	Teflon



**Single-side Open Non-stick Flat Sheet Pan**

CODE	SIZE	MAT.	COAT.
HBA5134	800 × 600 × 20mm	AluSteel 1,0mm	Teflon



**Right-angle Flat Sheet Pan**

CODE	SIZE	MAT.	COAT.
HBA5926	600 × 400 × 20mm	Al Alloy 1,5mm	Plain
HBA5925	800 × 600 × 20mm	Al Alloy 1,5mm	Plain
HBA5443	800 × 400 × 30mm	Al Alloy 1,2mm	Plain

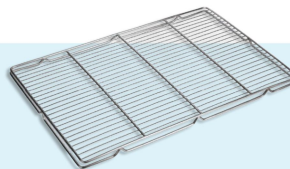

**Flat Cooling Rack**

CODE	SIZE	MAT.	COAT.
HBA5798	600 × 400 × 25mm	SUS 304 2,0mm	Etç.

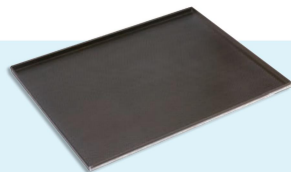

**Right-angle Perforated Non-stick Flat Sheet Pan**

CODE	SIZE	MAT.	COAT.
HBA4922	600 × 400 × 20mm	Al Alloy 1,5mm	Teflon
HBA5811	660 × 460 × 20mm	Al Alloy 1,5mm	Teflon

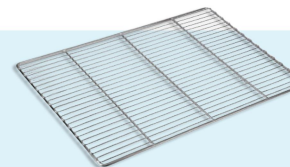

**Rack-supported Cooling Rack**

CODE	SIZE	MAT.	COAT.
HBA4860	600 × 400 × 6mm	SUS 201 1,2mm	Etç.



**Right-angle Non-stick Flat Sheet Pan**

CODE	SIZE	MAT.	COAT.
HBA5618	600 × 400 × 20mm	AluSteel 1,0mm	Teflon
HBA6340	800 × 500 × 20mm	AluSteel 1,0mm	Teflon
HBA4917	800 × 600 × 20mm	Al Alloy 1,5mm	Teflon

HONGBEI

**HONGBEI**  
**Deep-Drawn Hamburger Bun Pan**

- Seamless and Hygienic Design
- Perfectly Uniform Cavities
- Strong and Deformation-Resistant
- Even Heat Distribution
- Smooth Surface for Easy Release
- Customizable Layout and Size

**Customized Hamburger/Hot Dog Tray**

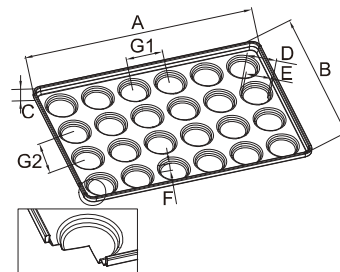

With only a few specifications we can manufacture your customized products

A. Overall Length
B. Overall Width
C. Height
D. Topin Diameter
E. Bottomin Diameter
F. Depth inside
G1/G2. Center-to-center distance

Material: Alu.Alloy  Alusteel  S/S

Thickness(Panel) \_\_\_\_\_

Thickness(Cup) \_\_\_\_\_

**Manufacture Craft:**



Pressed

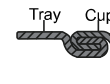

Lock Seam

**Rim Design:**



Round Wire



Flat Bar Band



**15 Indents Hamburger Bun Pan**

CODE	SIZE	MAT.	COAT.
HB85081	600 × 400 × 40mm	AluSteel 0,7mm	Teflon



**15 Indents Hamburger Bun Pan**

CODE	SIZE	MAT.	COAT.
HB84378	600 × 400 × 50mm	AluSteel 0,8mm	Teflon



**24 Indents Hamburger Bun Pan**

CODE	SIZE	MAT.	COAT.
HB86359	600 × 400 × 40,2mm	AluSteel 0,7mm	Teflon



**8 Indents Hot Dog Bun Pan**

CODE	SIZE	MAT.	COAT.
HB86356	600 × 400 × 40mm	AluSteel 0,8mm	Teflon



**14 Indents Hot Dog Bun Pan**

CODE	SIZE	MAT.	COAT.
HB86355	600 × 400 × 40mm	AluSteel 0,8mm	Teflon



**15 Indents Hot Dog Bun Pan**

CODE	SIZE	MAT.	COAT.
HB84098	600 × 460 × 36,5mm	AluSteel 0,8mm	Glaze silicone



**20 Indents Hamburger Bun Pan**

CODE	SIZE	MAT.	COAT.
HB85852	635 × 510 × 46mm	AluSteel 0,8mm	Glaze silicone

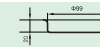

**15 Indents Hamburger Bun Pan**

CODE	SIZE	MAT.	COAT.
HB85248	653 × 450 × 39,4mm	AluSteel 0,8mm	Glaze silicone

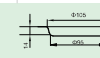

# HONGBEI

## Hamburger Bun Pan



**20 Indents Hamburger Bun Pan**

CODE	SIZE	MAT.	COAT.
HB83096	680 × 580 × 40mm	AluSteel 0,8mm	Plain



**12 Indents Hamburger Bun Pan**

CODE	SIZE	MAT.	COAT.
HB85998	600 × 600 × 40mm	AluSteel 0,8mm	Teflon

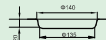

**24 Indents Hamburger Bun Pan**

CODE	SIZE	MAT.	COAT.
HB85078	800 × 600 × 40mm	AluSteel 0,7mm	Teflon



**30 Indents Hamburger Bun Pan**

CODE	SIZE	MAT.	COAT.
HB85585	800 × 600 × 33mm	AluSteel 0,7mm	Teflon



# HONGBEI

## Hamburger Bun Pan



**21 Indents Hot Dog Bun Pan**

CODE	SIZE	MAT.	COAT.
HB85408	800 × 600 × 35mm	AluSteel 0,7mm	Teflon



**32 Indents Hot Dog Bun Pan**

CODE	SIZE	MAT.	COAT.
HB85077	800 × 600 × 35mm	AluSteel 0,7mm	Teflon



**33 Indents Hot Dog Bun Pan**

CODE	SIZE	MAT.	COAT.
HB85076	800 × 600 × 35mm	AluSteel 0,7mm	Teflon



**18 Indents Hot Dog Bun Pan**

CODE	SIZE	MAT.	COAT.
HB84638	620 × 540 × 43mm	AluSteel 0,8mm	PFA



# HONGBEI

## Hamburger Bun Pan



**18 Indents Hot Dog Bun Pan**

CODE	SIZE	MAT.	COAT.
HB83721	565 × 520 × 4(1,3mm)	AluSteel 0,8mm	Glaze silicone



**15 Indents Hamburger Bun Pan**

CODE	SIZE	MAT.	COAT.
HB86528	738 × 503 × 42mm	AluSteel 0,8mm	PFA

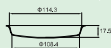

**24 Indents Hamburger Bun Pan**

CODE	SIZE	MAT.	COAT.
HB83719	738 × 503 × 42mm	AluSteel 0,8mm	PFA



**35 Indents Hamburger Bun Pan**

CODE	SIZE	MAT.	COAT.
HB86584	660 × 456 × 43mm	AluSteel 0,8mm	Teflon



# HONGBEI

## Hamburger Bun Pan



**12 Indents Hamburger Bun Pan**

CODE	SIZE	MAT.	COAT.
HB86043	600 × 400 × 32mm	AluSteel 0,8mm	Teflon



**24 Indents Hamburger Bun Pan**

CODE	SIZE	MAT.	COAT.
HB8165	700 × 470 × 42mm	AluSteel 0,8mm	Teflon



**12 Indents Hamburger Bun Pan**

CODE	SIZE	MAT.	COAT.
HB84932	660 × 460 × 33mm	AluSteel 0,7mm	Teflon



**30 Indents Hamburger Bun Pan**

CODE	SIZE	MAT.	COAT.
HB81743	800 × 600 × 21,5mm	Al Alloy 1,5mm	Teflon



HONGBEI

## Customized Baguette Baking Tray

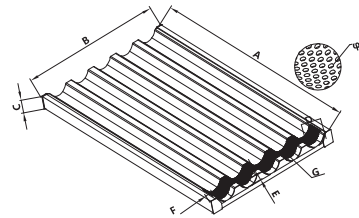

With only a few specifications we can manufacture your customized products

- A. Overall Length
- B. Overall Width
- C. Height
- D. Row Width
- E. Row Height
- F. End Width
- G. Holes Dimension

Material(Tray): Alu.Alloy  S/S

Material(Frame): Alu.Alloy

S/S

Thickness(Tray) \_\_\_\_\_

Thickness(Frame) \_\_\_\_\_

Right Angle

Round Corner

Open Ends

Closed Frame

### HONGBEI Baguette Baking Tray

*Even Baking Performance*

*Improved Crust Quality*

*Repeatable Baking Results*

*Reinforced Structural Strength*

*Optimized Air & Steam Flow*

*High Throughput Production*

# HONGBEI

## Baguette Baking Tray

### 4 Rows Baguette Tray

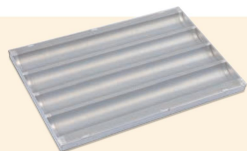

CODE	SIZE	MAT.	COAT.
HB84998	600 × 400 × 30mm	Al Alloy 1,0mm	Plain
Frame: Al Alloy			



### 4 Rows Baguette Tray

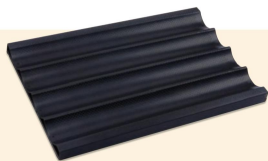

CODE	SIZE	MAT.	COAT.
HBF5822	600 × 400 × 40mm	Al Alloy 1,0mm	Teflon
Frame: S/S			



### 5 Rows Baguette Tray

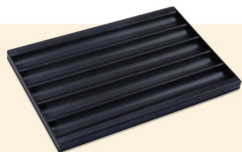

CODE	SIZE	MAT.	COAT.
HBF5720	600 × 400 × 30mm	Al Alloy 1,0mm	Teflon
HBF5799	600 × 400 × 30mm	Al Alloy 1,0mm	Plain
Frame: Al Alloy			



### 6 Rows Baguette Tray

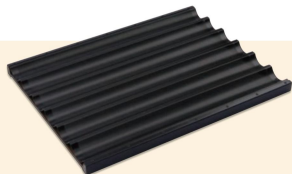

CODE	SIZE	MAT.	COAT.
HBF4194	800 × 600 × 40mm	Al Alloy 1,0mm	Teflon
Frame: S/S			



# HONGBEI

## Baguette Baking Tray

### 7 Rows Baguette Tray

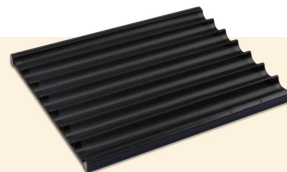

CODE	SIZE	MAT.	COAT.
HBF4196	800 × 600 × 40mm	Al Alloy 1,0mm	Teflon
Frame: S/S			



### 8 Rows Baguette Tray



CODE	SIZE	MAT.	COAT.
HB85477	800 × 600 × 30mm	Al Alloy 1,0mm	Teflon
Frame: Al Alloy			



### 8 Rows Baguette Tray

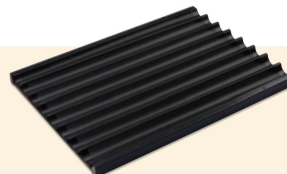

CODE	SIZE	MAT.	COAT.
HB84197	800 × 600 × 40mm	Al Alloy 1,0mm	Teflon
Frame: S/S			



### 9 Rows Baguette Tray



CODE	SIZE	MAT.	COAT.
HB82959	800 × 600 × 36mm	Al Alloy 1,2mm	Teflon
Frame: Al Alloy			



# HONGBEI

## Baguette Baking Tray

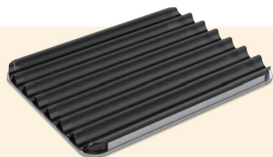

**7 Rows Baguette Tray**

CODE	SIZE	MAT.	COAT.
HB85476	800 × 600 × 30mm	Al Alloy 1,0mm	Teflon
Frame: Al Alloy			



**6 Rows Baguette Tray**

CODE	SIZE	MAT.	COAT.
HB85475	800 × 600 × 30mm	Al Alloy 1,0mm	Teflon
Frame: Al Alloy			



**5 Rows Baguette Tray**

CODE	SIZE	MAT.	COAT.
HBF5629	655 × 450 × 35mm	Al Alloy 1,0mm	Glaze silicone
Frame: Al Alloy			



**6 Rows Baguette Tray**

CODE	SIZE	MAT.	COAT.
HBF4097	655 × 455 × 30mm	Al Alloy 1,2mm	Glaze silicone
Frame: Al Alloy			



**7 Rows Baguette Tray**

CODE	SIZE	MAT.	COAT.
HBF5905	657 × 454 × 36,5mm	Al Alloy 1,5mm	Glaze silicone
Frame: Al Alloy			



**10 Rows Baguette Tray**

CODE	SIZE	MAT.	COAT.
HBF6773	645 × 450 × 20mm	Al Alloy 1,2mm	Glaze silicone
Frame: Al Alloy			

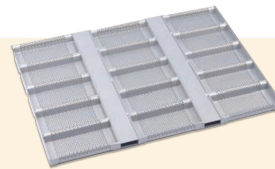

**15 Rows Baguette Tray**

CODE	SIZE	MAT.	COAT.
HBF4970	648 × 450 × 25mm	Al Alloy 1,2mm	Glaze silicone
HBF4971	648 × 450 × 25mm	Al Alloy 1,2mm	Glaze silicone
Frame: Al Alloy			

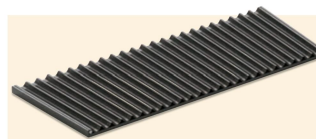

**24 Rows Baguette Tray**

CODE	SIZE	MAT.	COAT.
HBF4101	2000 × 800 × 49,5mm	Al Alloy 1,2mm	Teflon
Frame: Al Alloy			





HONGBEI

**HONGBEI  
Loaf Pan**

*High thermal conductivity  
Strong and durable structure  
Consistent loaf shape  
Efficient bakery production*

**Customized Loaf Pan**

With only a few specifications we can manufacture your customized products

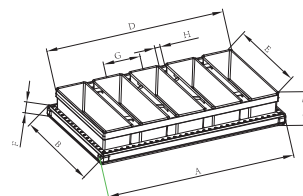
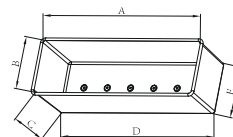

- A. Topin Length
  - B. Topin Width
  - C. Depth
  - D. Bottomin Length
  - E. Bottomin Width
- 
- A. Overall Length of Pan Set
  - B. Overall Width of Pan Set
  - C. Overall Height of Pan Set
  - D. Top Length of Strapped Pans (No Lid)
  - E. Top Width of Strapped Pans (No Lid)
  - F. Brace Width
  - G. Center-Center of Pans
  - H. Inner Gaps between Pans

**Material:** Alu.Alloy  Alu.steel  Thickness: \_\_\_\_\_

**Manufacture Craft:**

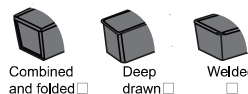

**Side Design:**

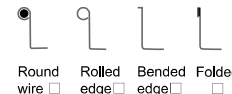

**Corrugated:**

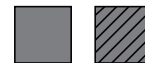

**Perforation:**

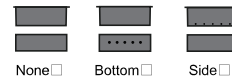

**Multi-strap:**

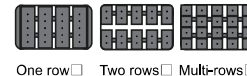

**Lid:**

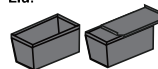

**Parts:**





**Loaf Pan**

**Capacity Options**

430g · 600g · 750g · 900g · 1000g · 1200g



**Loaf Pan**

CODE	SIZE	MAT.	COAT.
HBL6675	330 × 127 × 114mm	AluSteel 0,8mm	Glaze silicone
	Lid: 359 × 145mm		



**3-Strap Loaf Pan**

CODE	SIZE	MAT.	COAT.
HBL5255	590 × 190 × 76mm	AluSteel 0,8mm	Teflon
	Cup: 175 × 123 × 76mm		



**3-Strap Loaf Pan**

CODE	SIZE	MAT.	COAT.
HBL5256	590 × 242 × 76mm	AluSteel 0,8mm	Teflon
	Cup: 228 × 139 × 76mm		



**4-Strap Loaf Pan**(Al Alloy 1,0mm)

CODE	SIZE	SIZE (cup)	COAT.
HBL5053	595 × 209 × 123mm	205 × 106 × 120mm	Teflon
HBL6676	595 × 322 × 110mm	309 × 91 × 107mm	Teflon
HBL6677	595 × 340 × 125mm	325 × 106 × 120mm	Teflon



**4-Strap Loaf Pan**

CODE	SIZE	MAT.	COAT.
HBL5779	595 × 288 × 123mm Al Alloy 1,0mm		Teflon
	Cup: 270 × 110 × 120 mm		
	Lid: 590 × 298 × 22mm		



**5-Strap Loaf Pan**

CODE	SIZE	MAT.	COAT.
HBL5988	700 × 322 × 110mm Al Alloy 1,0mm		Teflon
	Cup: 309 × 91 × 107mm		
	Lid: 628 × 330 × 15mm		



**4-Strap Loaf Pan**

CODE	SIZE	MAT.	COAT.
HBL4761	590 × 260 × 118mm AluSteel 0,8mm		Teflon
	Cup: 240 × 124 × 118mm		
	Lid: 547 × 240 × 11mm		



**3-Strap Loaf Pan**

CODE	SIZE	MAT.	COAT.
HBL5262	432 × 425 × 120mm Cup: 311 × 177,8 × 76mm	AluSteel 0,8mm	Glaze silicone



**3-Strap Loaf Pan**

CODE	SIZE	MAT.	COAT.
HBL5632	661 × 314 × 69,6mm Cup: 270 × 110 × 120mm	AluSteel 0,8mm	Glaze silicone



**5-Strap Loaf Pan**

CODE	SIZE	MAT.	COAT.
HBL5912	586 × 164 × 80,5mm Cup: 164 × 80 × 80,5mm	AluSteel 0,7mm	Teflon



**5-Strap Loaf Pan**

CODE	SIZE	MAT.	COAT.
HBL5593	760 × 225 × 102mm Cup: 210 × 100 × 100mm	AluSteel 0,8mm	Teflon



**10-Strap Loaf Pan**

CODE	SIZE	MAT.	COAT.
HBL6569	800 × 600 × 70mm Cup: 244 × 125 × 65mm	AluSteel 0,8mm	Teflon

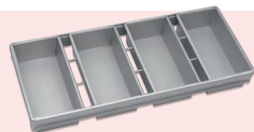

**4-Strap Loaf Pan**

CODE	SIZE	MAT.	COAT.
HBL5239	655 × 275 × 81mm Cup: 255 × 127 × 80mm	Al Alloy 1,0mm	Glaze silicone



**4-Strap Loaf Pan**

CODE	SIZE	MAT.	COAT.
HBL3844	590 × 337 × 103mm Cup: 320 × 100 × 100mm	Al Alloy 1,0mm	Teflon



**16-Strap Loaf Pan**

CODE	SIZE	MAT.	COAT.
HBL6570	800 × 600 × 66mm Cup: 175 × 105 × 65mm	AluSteel 0,8mm	Teflon

HONGBEI

## HONGBEI Muffin Tray

Integrated design engineered for mass production  
 Consistent heat distribution for uniform baking results  
 Premium non-stick coating for clean release  
 Optimized efficiency with reduced operational cost  
 Robust construction for intensive industrial use  
 Flexible customization to fit diverse production needs

## Customized Muffin Tray

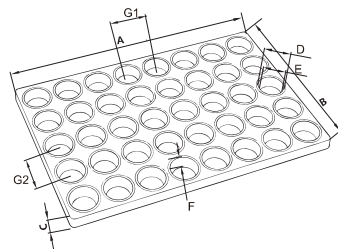

With only a few specifications we can manufacture your customized products

A. Overall Length
B. Overall Width
C. Height
D. Topin Diameter
E. Bottomin Diameter
F. Depth inside
G1/G2. Center-to-center distance

### Panel & Corners

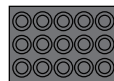

Square Corner

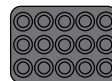

Round Corner

### Manufacture Craft:

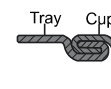

Lock Seam

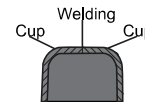

Laser Welding

### Panel Design:



Folded



With Frame



Round Rim



Square Band

### Perforation in cups:



None



One Hole



Holes



**36-Cavity Madeleine Baking Pan**

CODE	SIZE	MAT.	COAT.
HBD4063	400 × 600 × 25mm	AluSteel 0,8mm	Glaze silicone



**40-Cavity Muffin Baking Pan**

CODE	SIZE	MAT.	COAT.
HBD5674	400 × 600 × 32mm	AluSteel 0,8mm	Glaze silicone



**40-Cavity Half Round Baking Pan**

CODE	SIZE	MAT.	COAT.
HBD7221	400 × 600 × 32mm	AluSteel 0,8mm	Glaze silicone



**15-Cavity Perforated Muffin Baking Pan**

CODE	SIZE	MAT.	COAT.
HBD5140	400 × 600 × 30mm	AluSteel 0,8mm	Teflon

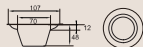

**24-Cavity Square Muffin Pan**

CODE	SIZE	MAT.	COAT.
HBD6689	460 × 660 × 38mm	AluSteel 0,7mm	Teflon



**24-Cavity Muffin Baking Pan**

CODE	SIZE	MAT.	COAT.
HBD3931	450 × 654 × 32mm	AluSteel 0,8mm	Teflon



**48-Cavity Muffin Pan with Cup Slots**

CODE	SIZE	MAT.	COAT.
HBD5141	597 × 797 × 26,5mm	Al Alloy 1,5mm	Plain



**24-Cavity Muffin Baking Pan**

CODE	SIZE	MAT.	COAT.
HBD6771	355 × 532 × 37mm	AluSteel 0,8mm	Glaze silicone



HONGBEI

## HONGBEI Silicone Baking Mold

*Cost-effective alternative to disposable baking paper*

*Reusable design reduces material waste*

*Heat-resistant with stable performance*

*Food-grade, non-toxic and recyclable materials*

*Environmentally friendly with lower Overall impact*

*Consistent baking results with improved efficiency*

## Customized Silicone Baking Mold

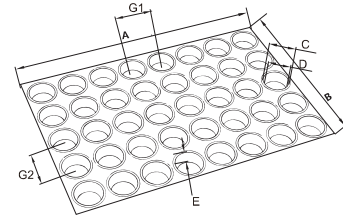

With only a few specifications we can manufacture your customized products

A. Overall Length

B. Overall Width

C. Top-in Diameter

D. Bottom-in Diameter

E. Depth inside

G1/G2. Center-to-center distance

### Single-Side Silicone Mold

1. Non-stick silicone coating on one side
2. Reinforced with fiberglass for stability
3. Ideal for structured baking and easy release



### Perforated Silicone Mold

1. Open / perforated design for optimal airflow
2. Enhances heat circulation and baking efficiency
3. Perfect for crispy crust and consistent results



**8-Cavity Silicone Hot Dog Mold**

CODE	SIZE	MAT.
HBDP003	400 × 600 × 30mm	Fiberglass+ Silicone

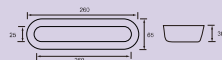

**24-Cavity Silicone Hot Dog Mold**

CODE	SIZE	MAT.
HBDP033H	400 × 600 × 22mm	Fiberglass+ Silicone

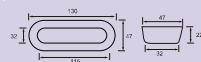

**12-Cavity Silicone Bun Mold**

CODE	SIZE	MAT.
HBDP008	400 × 600 × 40mm	Fiberglass+ Silicone



**15-Cavity Silicone Bun Mold**

CODE	SIZE	MAT.
HBDP007	400 × 600 × 20mm	Fiberglass+ Silicone

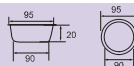

**24-Cavity Silicone Bread Mold**

CODE	SIZE	MAT.
HBSE500	400 × 600 × 40mm	Fiberglass+ Silicone

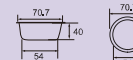

**30-Cavity Silicone Bun Mold**

CODE	SIZE	MAT.
HBDP052	600 × 800 × 20mm	Fiberglass+ Silicone

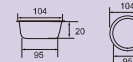

**7-Cavity Silicone Baguette Mold**

CODE	SIZE	MAT.
HBDP044	600 × 800 × 35mm	Fiberglass+ Silicone



**24-Cavity Silicone Bun Mold**

CODE	SIZE	MAT.
HBST090	500 × 745 × 30mm	Fiberglass+ Silicone

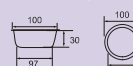

# HONGBEI

## HONGBEI Baking Trolley

- Heavy-duty structure with stable load capacity
- Smooth mobility for easy handling
- Multi-tier design for efficient space utilization
- Compatible with various trays and production lines
- Durable construction for intensive use
- Customizable size and layer configuration

## Customized Baking Trolley

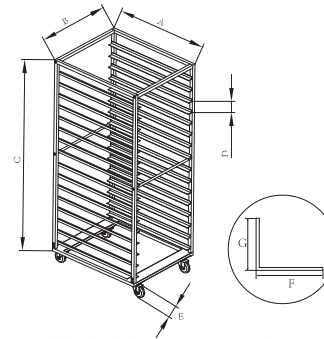

With only a few specifications we can manufacture your customized products

- A.Length of rack
- B.Width of rack
- C.Height of rack(not including caster)
- D.Distance between runners
- E.Height of caster
- F.Width of runner
- G.Height of runner

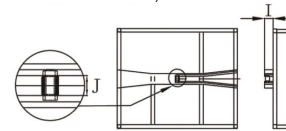

Information Required for Custom Oven Trolley

- I.Height of top guider
- J.Hook wheel width
- K.C-C of bottom tube (different style)

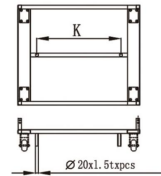

Select Right Casters



- TPR Wheel
- PU Wheel
- Hi-Temp
- Low-Temp
- Heavy Duty

Oven Trolley Fixed Structure



"A" Lift

"B" Lift

"C" Lift

"D" Lift

"A" Bottom

"B" Bottom



**15-Tier Bakery Trolley**

CODE	SIZE	MAT.
HBT7228	930 × 730 × 1807mm	S/S 304 – 1.5mm
Suitable for 460 × 660mm baking pan		



**48-Tier Bakery Trolley**

CODE	SIZE	MAT.
HBT6643	720 × 520 × 2000mm	S/S 304 – 2.0mm
Suitable for 460 × 660mm baking pan		



**20-Tier Bakery Trolley**

CODE	SIZE	MAT.
HBT4887	660 × 510 × 1750mm	Al Alloy
Suitable for 460 × 660mm baking pan		



**10-Tier Bakery Trolley**

CODE	SIZE	MAT.
HBT4888	660 × 510 × 965mm	Al Alloy
Suitable for 460 × 660mm baking pan		



**12-Tier Bakery Trolley**

CODE	SIZE	MAT.
HBT5616	915 × 736 × 1765mm	S/S 304 – 1.5mm
Suitable for 460 × 660mm baking pan		



**15-Tier Bakery Trolley**

CODE	SIZE	MAT.
HBT3854	660 × 520 × 1750mm	S/S 304 – 1.5mm
Suitable for 460 × 660mm baking pan		

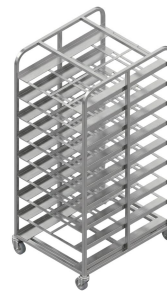

**9-Tier Bakery Trolley**

CODE	SIZE	MAT.
HBT5617	915 × 736 × 1765mm	S/S 304 – 1.5mm
Suitable for 460 × 660mm baking pan		



**16-Tier Bakery Trolley**

CODE	SIZE	MAT.
HBT5915	815 × 665 × 1750mm	S/S 304 – 1.5mm
Suitable for 400 × 600mm / 600 × 800mm baking pan		



**15-Tier Bakery Trolley**

CODE	SIZE	MAT.
HBT7117	815 × 665 × 1750mm	S/S 304 – 1.5mm
Suitable for 400 × 600mm / 600 × 800mm baking pan		



**16-Tier Bakery Trolley**

CODE	SIZE	MAT.
HBT4603	815 × 665 × 1750mm	S/S 304 – 1.5mm
Suitable for 400 × 600mm / 600 × 800mm baking pan		



**15-Tier Bakery Trolley**

CODE	SIZE	MAT.
HBT5275	805 × 636 × 1798mm	S/S 304 – 1.5mm
Suitable for 400 × 600mm / 600 × 800mm baking pan		

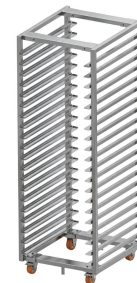

**20-Tier Bakery Trolley**

CODE	SIZE	MAT.
HBT3796	825 × 675 × 1930mm	S/S – 1.2mm
Suitable for 400 × 600mm / 600 × 800mm baking pan		



**16-Tier Bakery Trolley**

CODE	SIZE	MAT.
HBT6548	800 × 660 × 1972mm	S/S – 1.5mm
Suitable for 400 × 600mm / 600 × 800mm baking pan		



**16-Tier Bakery Trolley**

CODE	SIZE	MAT.
HBT5955	650 × 460 × 1660mm	S/S 304 – 1.5mm
Suitable for 400 × 600mm baking pan		



**10-Tier Bakery Trolley**

CODE	SIZE	MAT.
HBT3559	930 × 615 × 1900mm	S/S – 2.0mm
Suitable for 600 × 800mm baking pan		



**10-Tier Bakery Trolley**

CODE	SIZE	MAT.
HBT6643	1280 × 810 × 1900mm	S/S – 2.0mm
Suitable for 600 × 800mm baking pan		



**10-Tier Bakery Trolley**

CODE	SIZE	MAT.
HBT3556	1065 × 810 × 1900mm	S/S - 2.0mm
Suitable for 500 × 800mm baking pan		



**Stainless Steel Trolley**

CODE	SIZE	MAT.
HBT3854	845 × 675 × 980mm	S/S - 1.5mm
Suitable for 400 × 600mm / 600 × 800mm baking pan		



**Bakery Trolley for 10" Cake Pans**

CODE	SIZE	MAT.
HBT5484	1424 × 833 × 1422mm	S/S - 1.5mm



**Round Mixing Bowl Transport Trolley**

CODE	SIZE	MAT.
HBT6672	φ442 × 1000mm	S/S 304 - 1.5mm



**Aluminum Platform Trolley**

CODE	SIZE	MAT.
HBT7116	620 × 420 × 140mm	Al Alloy
Suitable for 400 × 600mm baking pan		



**Bread Cooling Trolley**

CODE	SIZE	MAT.
HBT5072	1820 × 605 × 1760mm	S/S - 1.5mm



**Baking Tray Washing Trolley**

CODE	SIZE	MAT.
HBT5485	1200 × 650 × 1850mm	S/S 304 - 1.5mm

# Pan Use & Care

## PTFE Non-stick Products

### Instructions

- Suitable for baking bread products.
- Before first use: clean, dry, apply solid edible oil, heat empty in oven at ~180°C for 8–10 minutes. After cooling, wipe off oil. This improves performance and lifespan.
- Use a soft cloth or scraper to remove residue.
- Clean regularly with warm water and neutral detergent.
- Slight deformation may occur within the first 30–90 days due to thermal expansion and contraction—this is normal.

### Maintenance

- Do not use steel wool, abrasive pads, or chemical cleaners.
- Handle gently to avoid damage to coating.
- Do not leave in humid or sugary environments after use.
- Recommended baking temperature  $\leq 240^{\circ}\text{C}$ . Avoid dry heating and uneven heating.

## Silicone Non-stick Products

### Instructions

- Suitable for high-sugar cakes.
- First use same as above (oil + heating).
- Clean residue with soft cloth.
- Wash regularly with warm water and neutral detergent.

### Maintenance

- Use soft cloth and neutral cleaner.
- Avoid impact and friction.
- Avoid long exposure to moisture, starch, and sugar.
- Temperature  $\leq 240^{\circ}\text{C}$ . No dry heating. Avoid uneven heating.
- When not in use, lightly oil surface, store in plastic bag in dry place.

## Anodized Products

### Instructions

- Clean, dry, lightly oil before first use.
- After baking, clean crumbs with soft scraper or cloth.
- Clean regularly with warm water and neutral detergent.

### Maintenance

- Do not use sharp tools or chemical cleaners.
- Do not soak for long periods.
- Do not freeze dough in refrigeration.
- Handle gently to avoid scratches.
- Recommended:
  1. Temperature  $\leq 250^{\circ}\text{C}$
  2. No empty heating
  3. Avoid uneven heating

## Other Products

- **Hard molds:** Do not use steam cleaning; may cause oxidation.
- **Trolleys:** Do not use high-pressure water; may rust bearings and damage wheels. Use according to product conditions.