

Integrated Circulating Aquaculture System

Tel: +86-18520739875 (Wechat / Whatsapp)

Email : qlozone@qlozone.com

Web: www.qlozone.com | www.glozone.cn



APPLICATION

Customer photo taken

Mechanical filtration system

Protein separation system

Biochemical filtration system

Oxygenation system

Water quality monitoring system (optional)

Thermostatic system (optional)

Electronic control system

Ultraviolet sterilization system

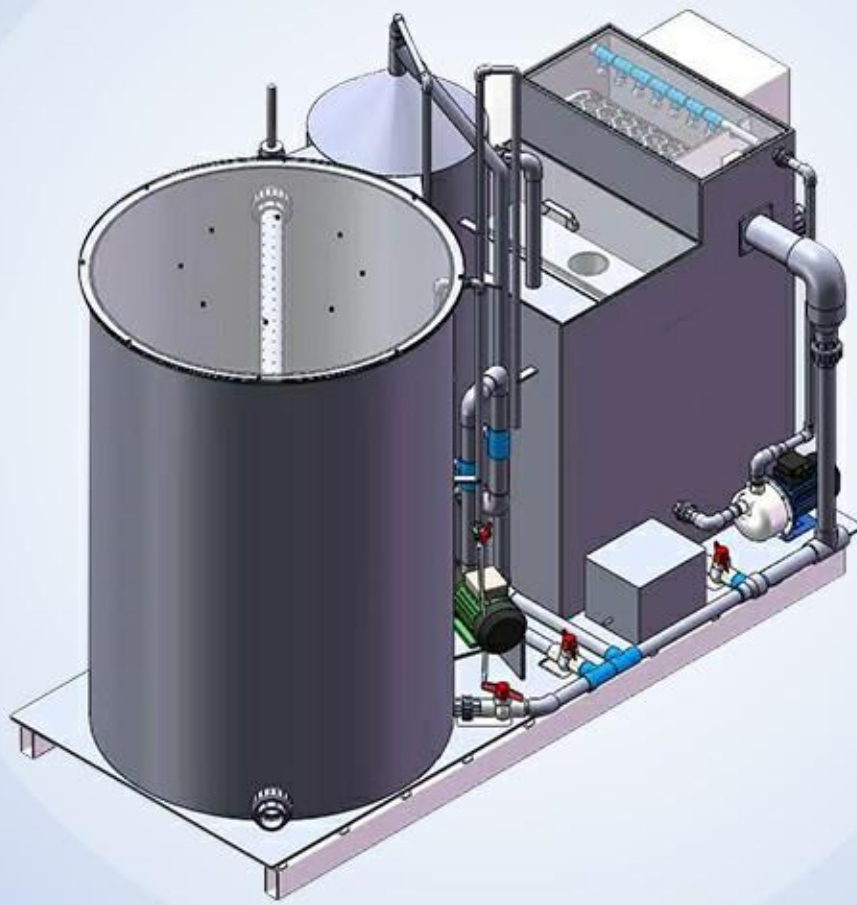

Farm



Villa



Seafood Restaurant



Seafood Wholesale Market

Easy to install
Easy to use



Product Overview

Qili integrated circulating water aquaculture equipment, integrating microfiltration, precipitation, ultraviolet disinfection, biochemical + filler, backwash pump, circulating water pump, and electric control cabinet. It is exquisitely designed and simple to install. It only needs to plug in and connect the water in and out. That is, the integrated circulating water system can effectively filter residual bait and fish in the water, effectively degrade ammonia nitrogen and nitrite, and is equipped with automatic backwashing and dirt collection, which can quickly clean and drain.

www.qlozone.com

Workflow

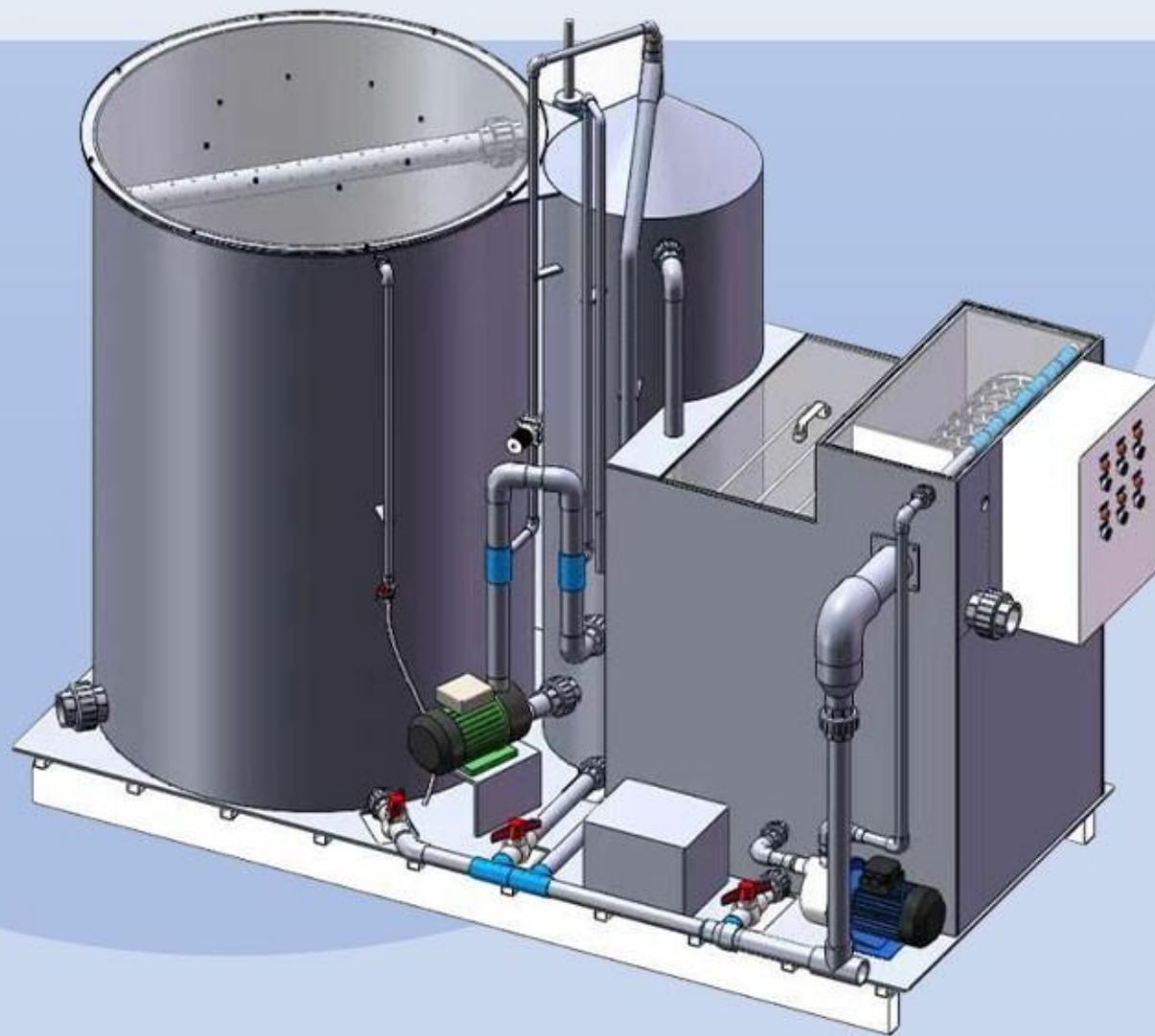
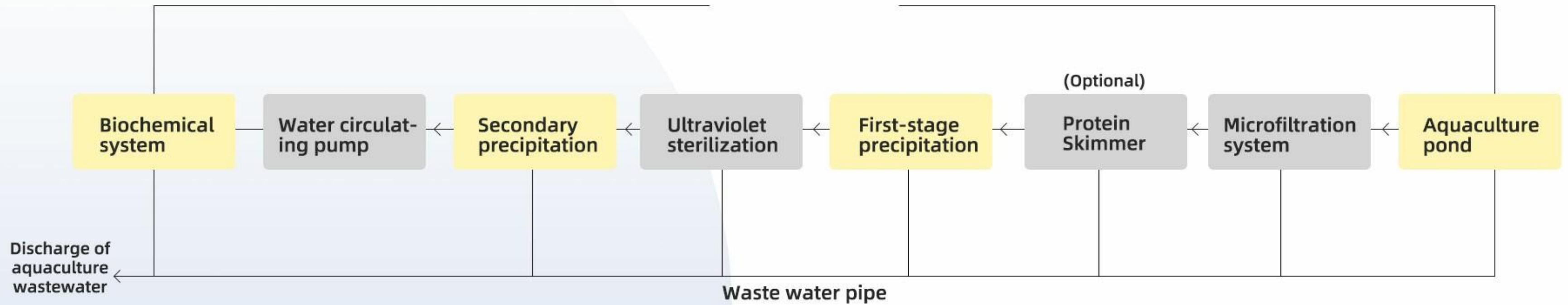

SAVE LABOR COSTS

Easy and easy to construct



SPACE SAVING

Integrated design, small footprint



EFFECTIVE WATER PRESSURE STABILIZATION

With its own electrical cabinet, only plug in power and approach the water outlet.



DIRECT USE

No excessive consumables required



LONG SERVICE LIFE

Thicker PP material for long service life



EASY INSTALLATION

With its own electrical cabinet, only plug in power and approach the water outlet

INTEGRATED CIRCULATING AQUACULTURE SYSTEM

Product parameters

Model	QL-10	QL-20	QL-30
Water volum	10m3	20m3	30m3
Temperature	22-30°C		
Size	2.2*1*1.65	2.5*1.4*1.75	3.0*1.55*1.7
Total power	1240w	1395w	1385w
Circulation pump	Water flow rate: 10000L/H Power: 50W	Water flow rate: 20000L/H Power: 75W	Water flow rate: 30000L/H Power: 65W
Power of Backwash pump	1000W	1000W	1000W
Biochemical gas pump	Water flow rate: 120L/min Power: 95W	Water flow rate: 200L/min Power: 160W	Water flow rate: 200L/min Power: 160W
Aeration pump	Water flow rate: 120L/min Power: 95W	Water flow rate: 200L/min Power: 160W	Water flow rate: 200L/min Power: 160W
Maximum breeding density	50-80kg/m3		
UV power	60w		
Optional	Ozone machine / Oxygen generator / Dissolved oxygen cone		

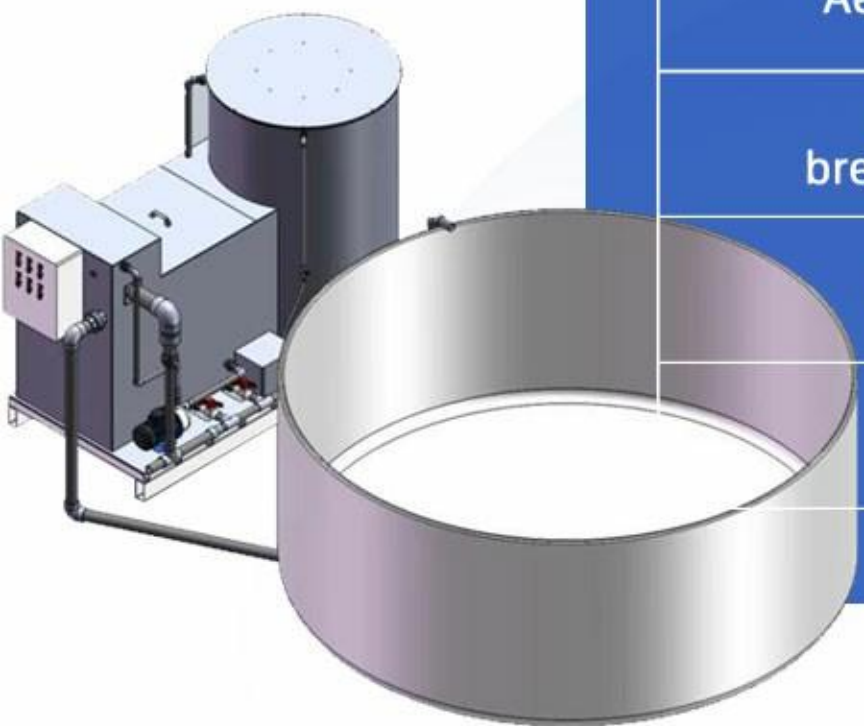



OPTIONAL ACCESSORIES



Ozone generator



Oxygen concentrator



Oxygen cone

QUALITY DETAILS

Customer photo taken

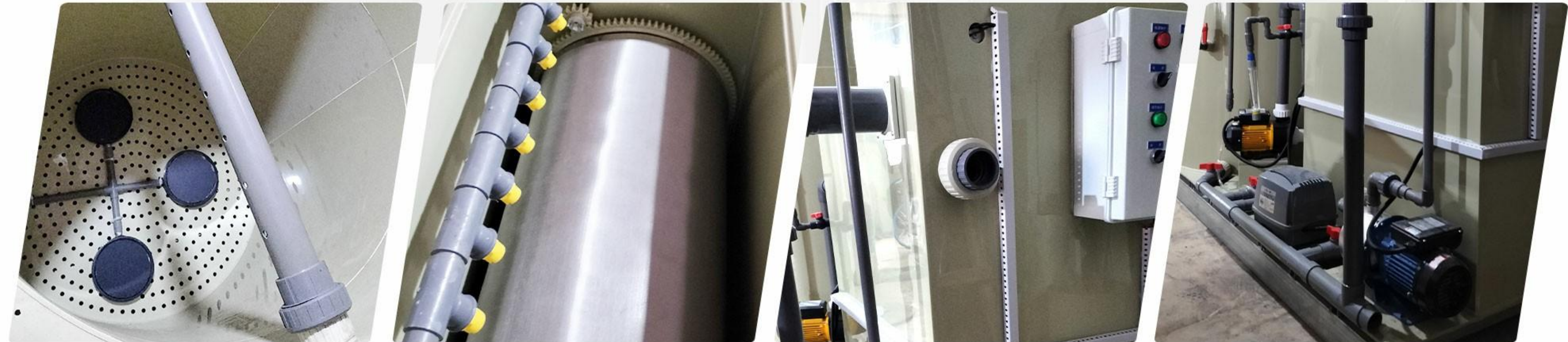

About us



Guangzhou Qili Environmental Equipment Co., Ltd is a high-tech enterprise dedicated to research, development, design, production and sales of ozone equipment. Specializing in ozone technology research, ozone equipment design and manufacturing, ozone application engineering design and ozone system equipment installation, commissioning, operation and maintenance. In the modern fish pond breeding, kitchen cooking fumes, water treatment, air treatment and other related fields have a wealth of experience! Qili air source, oxygen source, pipeline-specific, ozone water machine, oxygen generator, ozone detector and other products are sold at home and abroad.

Professional Team



Factory Show

