



ELESHELL- 14.3/16K

User Manual

Model

ELESHELL-14.3/16K

Light up every corner of the world with renewable energy.

Content

1	General Information	2
1.1	Validity	2
1.2	Intended Use	2
1.3	Product Identification	3
2	Safety Measures	4
3	Technical Parameters	5
4	Technical Items	6
5	Product Overview	7
5.1	Brief Introduction	7
5.2	Hardware and Instructions	7
5.2.1	Start Button	8
5.2.2	Dip Switch Definition	8
5.2.3	COM1 Port	9
5.2.4	COM2 Port	10
5.2.5	Battery Indicator Light	10
6	Installation Guide	11
6.1	Inspection Before Installation	12
6.1.1	Check the Outer Packaging	12
6.1.2	Check Whether the Accessories are Complete	12
6.2	Tools	15
6.3	Installation Requirements	16
6.3.1	Installation Environment Requirements	16
6.3.2	Installation Carrier Requirements	16
6.4	Installation Instructions	17
6.4.1	Overall Dimensions	17
6.4.2	Connection of All Wires	18
7	Cleaning and Maintenance	21
7.1	Cleaning Work	21
7.2	Maintenance	21
7.2.1	Recharging Requirements During Normal Storage	21
7.2.2	Recharging Requirements for Excessive Discharge	22
8	Common Issues and Solutions	23
8.1	Common Issues and Solutions	23
8.2	Emergency	25
8.3	Handling of the Battery System	25

1 General Information

This manual introduces the **ELESHELL-14.3/16K** battery products. Please read this manual carefully before using the battery. For any questions, please contact EITAI immediately for advice and clarification.

1.1 Validity

This user manual is applicable to **ELESHELL-14.3/16K**.

This manual contains **ELESHELL-14.3/16K** information, usage, guidance, safety information, installation guide and details on common operation issues and subsequent maintenance measures.

1.2 Intended Use

ELESHELL-14.3/16K is an energy storage unit, that is designed for residential application scenarios with the capability of short-term backup.

Notes:

ELESHELL-14.3/16K is not suitable for supporting life-sustaining medical devices. This product is intended for use only in accordance with the information provided in the enclosed documents and applicable local standards and regulations. Any other use may result in personal injury or property damage. The illustrations in this manual are only intended to help explain the concept of the system configuration, including use guidelines, safety precautions, common operating problems, and subsequent battery maintenance.

Alterations to the product, e.g. changes or modifications, are only permitted with the express written permission of EITAI. Unauthorized changes will not be allowed by warranty claims. EITAI shall not be liable for any damage resulting from such changes. Any use of the product other than described in the intended use section does not qualify as appropriate. The enclosed documentation is an integral part of this product. Please keep the documentation in a safe and convenient place for future reference.

Product model labels (see Section 1.3) must be attached to the product.

1.3 Product Identification

The type labels were attached on the product, which contain the product identification information. For safe usage, the user must be well-informed of the contents in the type labels.

The Labels include:

	Lithium-ion Battery Pack	
Model:	ELESHELL14.3K	
Ratings:	14336Wh/51.2V/280Ah	
Charge Voltage:	57.9V	
Max.Output Power:	10240W	
Maximum Discharge Current:	200A	
Manufacturer:	EiTai	
Eitai (Xiamen) New Energy Technology Co., Ltd.		
Unit 2101 NO.8, Chengyi North Street, Software Park Phase III, High-tech Zone, Xiamen City, China		
CAUTION!		
<ul style="list-style-type: none">Do not disassembleDo not short-circuitDo not place in fire or near hot sourcePlease read user manual carefully		
CE,MSDS,UN38.3		

	Lithium-ion Battery Pack	
Model:	ELESHELL16K	
Ratings:	16077Wh/51.2V/314Ah	
Charge Voltage:	57.9V	
Max.Output Power:	10240W	
Maximum Discharge Current:	200A	
Manufacturer:	EiTai	
Eitai (Xiamen) New Energy Technology Co., Ltd.		
Unit 2101 NO.8, Chengyi North Street, Software Park Phase III, High-tech Zone, Xiamen City, China		
CAUTION!		
<ul style="list-style-type: none">Do not disassembleDo not short-circuitDo not place in fire or near hot sourcePlease read user manual carefully		
CE,IEC62619,ROHS,MSDS,UN38.3		



DANGER !
CHEMICAL HAZARD & SHOCK HAZARD

- Do not disassemble or repair by yourself.
- Do not drop, deform, impact, cut or spearing with a sharp object.
- Do not place near open flame or incinerate.
- Do not put any objects onto the battery.
- Do not allow to contact with liquid.
- Keep out of reach of children, animals or insects.
- Contact the supplier within 24 hours if anything wrong.

WARNING !

Stop the battery operation immediately to secure the battery safety when environmental temperature is over working temperature (suitable operation temperature is 0~45°C).
If battery is at high temperature usually, it will impact battery performance.

2 Safety Measures

This section contains safety information that must always be observed when using or installing batteries. To prevent personal injury or property damage and ensure long-term operation of the batteries, please read this section carefully, always watch for warnings   from all safety messages.

Environmental requirements:

1. Do not expose the battery to temperature above 50°C;
2. Do not place the battery near any heat source;
3. Do not expose the battery to moisture or liquid;
4. Do not expose the battery to a corrosive gas or liquid;
5. Do not expose the battery to a combustible gas or liquid;
6. Do not expose the battery to direct sunlight for extended periods of time;
7. Battery power terminals are not allowed to contact conductive objects, such as electric wires;
8. Place the battery in safe place that away from children and animals.

Operation Precautions:

1. Do not disassemble the battery;
2. Do not touch the battery pack with wet hands;
3. Do not smash, fall, or puncture the battery;
4. Do not reverse the polar series connection battery;
5. Do not short-circuit the terminal, and remove all metal jewelry items that may produce a short-circuit before installation and repair;
6. Always handle the products in accordance with the local safety regulations;
7. Store and use the battery in the user's manual;
8. Ensure reliable grounding;
9. Disconnecting all batteries to the wires before installation and repair;
10. Do not stack batteries outside the protective packaging during storage or handling;
11. The stacking of packaging batteries shall not exceed the quantity specified on the packaging;
12. Continued operation of a damaged battery may lead to dangerous situations, causing serious injuries such as electric shock or combustion.

3 Technical Parameters

Basic Parameters	Technical Specification	
Model	ELESHELL 14.3K	ELESHELL 16K
Battery Type	LiFePO4	LiFePO4
Nominal Capacity (Ah)	280Ah	314Ah
Nominal Voltage (V)	51.2V	51.2V
Total Energy	14336W.h	16077W.h
Depth of Discharge (90%DOD)	12902W.h	14469W.h
Maximum Charging Voltage (V)	57.9V	
End of Voltage (V)	46.4V	
Maximum Current (A)	200A	
Maximum Power (W)	10240W	
Working Humidity	≤95%rh	
Store Humidity	≤95%rh	
Working Altitude	≤2000m	
Maximum Number of Parallel	15 pcs	
Protection Level	IP54	
Net Weight (Kg)	127Kg	129Kg
Dimensions (mm)	780*415*255mm	780*415*255mm
Product Certificate	CE, MSDS, UN38.3	CE, IEC62619, ROHS, MSDS, UN38.3
Circle Life	≥10000 times	
Communication Port	CAN, RS485, RS232	
Operating Temperature	0°C ~ 60°C	
Storage Temperature	≤25°C, 12 months;	
	≤35°C, 6 months;	
	≤45°C, 3months.	

Note: Operating current derating according to the cell voltage and temperature.

4 Technical Items

No.	Name	Comment
1	Discharge	Battery output power for load
2	Charge	Put the electricity into the battery through the charger
3	Full charge	The battery is fully charged with 100% SOC
4	Standby	Ready for charging or discharging
5	Turn-off	Turn-off battery output
6	SOC	State of charging (Useable capacity)
7	Battery voltage	Voltage between the battery B+ /B -
8	Single-string voltage	Single-cell voltage
9	Alarm	Indicates that the battery is in an abnormal state
10	Protection	Battery stops charging or discharging
11	Fault	Battery or BMS is damaged and need to be replaced
12	Over discharged	Battery is lack of electricity, and need to be charged in time

5 Product Overview

5.1 Brief Introduction.

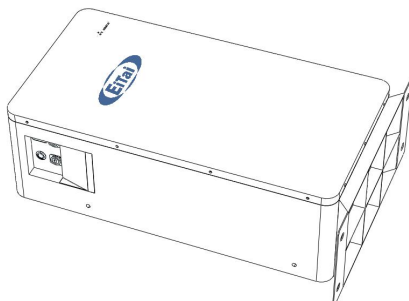

ELESHELL-14.3/16K is a lithium battery energy storage system with an operating voltage range of between 46.4~57.9V, it is used for household energy storage applications, in cooperation with low voltage inverters to achieve home energy storage purpose.

ELESHELL-14.3/16K has a built-in BMS (Battery Management System) which can manage and monitor cells information, including voltage, current and the temperature. In addition, the BMS can balances battery charging to extend lifespan. BMS has the protections including over-discharge, overcharge, over-current, high / low temperature, etc.

The system can automatically manage the charging status, discharge state, balance state. Multiple batteries can be connected in parallel to expand storage capacity to meet larger capacity and continuous power support time, **ELESHELL-14.3/16K** support up to 15 parallel operations.

5.2 Hardware and Instructions

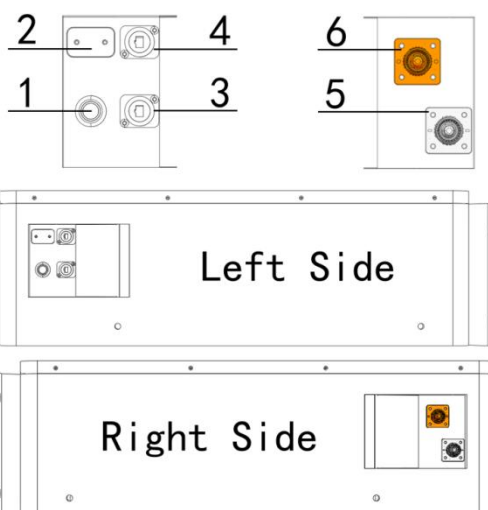

No	Items	No	Items
1	Power switch	2	ADDR dial address
3	COM1(RS485/CAN)	4	COM2(RS485/RS232)
5	Battery negative pole	6	Battery positive pole

5.2.1 Start Button

Press the start button, release the button, and the button is locked.

5.2.2 Dip Switch Definition

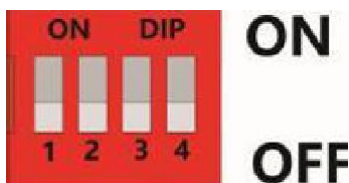

Schematic Diagram Of the Dial-up Switch

The dial-dip switch is used to set the BMS address of each battery. The code value of the dial-ON position is 1, and the code value of the dial-1234 position is 0.

The host battery address is 1, and the slave battery address is 2 to 15. (The host is connected to the inverter, and the slave machines are arranged in numerical order according to the address)

The dial-up address table is as follows:

Dial-up code location				Add	Dial-up code location				Add	Dial-up code location				Add	Dial-up code location				Add
#1	#2	#3	#4		#1	#2	#3	#4		#1	#2	#3	#4		#1	#2	#3	#4	
0	0	0	0	X	0	0	1	0	4	0	0	0	1	8	0	0	1	1	12
1	0	0	0	1	1	0	1	0	5	1	0	0	1	9	1	0	1	1	13
0	1	0	0	2	0	1	1	0	6	0	1	0	1	10	0	1	1	1	14
1	1	0	0	3	1	1	1	0	7	1	1	0	1	11	1	1	1	1	15

5.2.3 COM1 Port

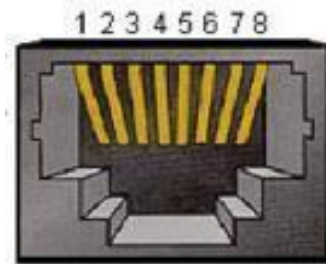

	Definition description
PIN 1	RS485-B
PIN 2	RS485-A
PIN 3	NC (empty)
PIN 4	CAN-H
PIN 5	CAN-L
PIN 6	NC (empty)
PIN 7	RS485-A
PIN 8	RS485-B

The CAN communication terminal (RJ45 port) follows the CAN/RS485 protocol and connects to the inverter BMS for communication. The BMS controls the charging current/charging voltage or discharge current/discharge cut-off voltage of the inverter based on the battery voltage and battery temperature through CAN/RS485 communication.

5.2.4 COM2 Port



	Definition description
PIN 1	RS485-B
PIN 2	RS485-A
PIN 3	RS232-TX
PIN 4	RS232-RX
PIN 5	RS232-GND
PIN 6	NC (empty)
PIN 7	RS485-A
PIN 8	RS485-B

Com2 communication terminal (RJ45 port) follows RS485 / RS232 protocol and communicates internally when multiple batteries are combined or connect the PC.

5.2.5 Battery Indicator Light

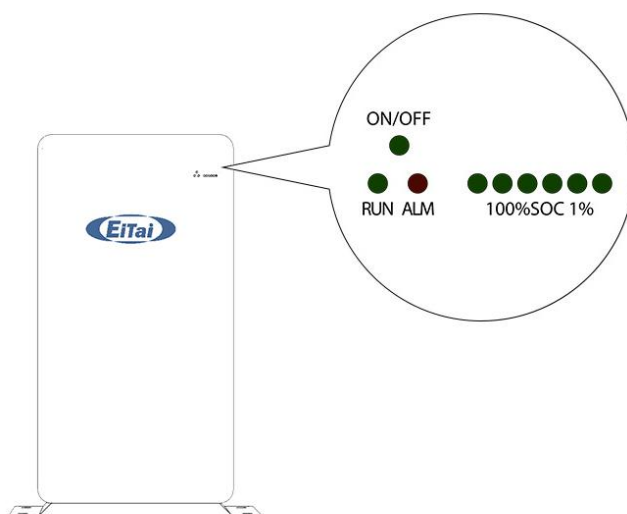

When the "Power Switch" button is pressed, the product is enabled, and all LED indicator lights will flash for a short time, which is a normal phenomenon. "RUN" is the running light of the product. When the product is working normally, the "RUN" is green on; When the product is not working, the "RUN" light goes off.

"ALM" is the alarm light for the product. When the product is running normally, the "ALM" is off; "ALM" displays a red light when the product is faulty.

"SOC" is a battery margin indicator. It consists of six LED lights, all six of which turn green when the product is fully charged.

When the product is working, the "ON/OFF" LED appears green.

6 Installation Guide

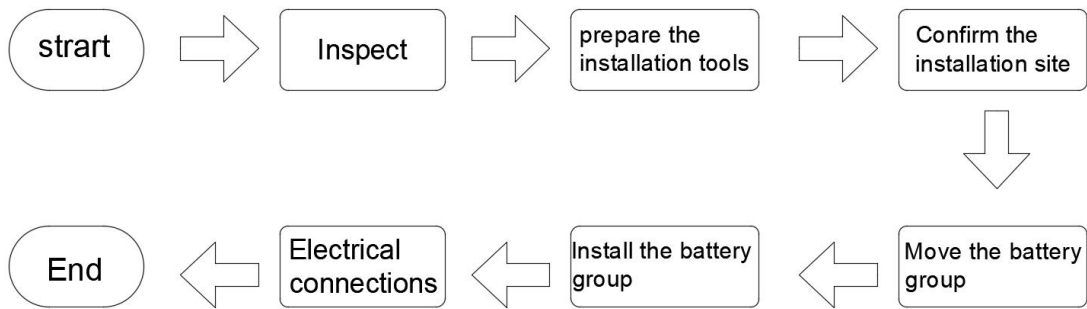

Installation flow chart

6.1 Inspection Before Installation

6.1.1 Check the Outer Packaging

Packaging materials and components may be damaged during transportation. Therefore, please check the packaging material before installing the battery. Check the surface of packaging materials for damage, such as holes and cracks. If any damage is found, do not unpack the battery and contact the dealer as soon as possible. It is recommended that you remove the packaging material within 24 hours before installing the battery.

6.1.2 Check Whether the Accessories are Complete

After opening the packing box, check whether the attached accessories are complete. If any damage or missing parts are found, contact your dealer.

Accessories list in the package

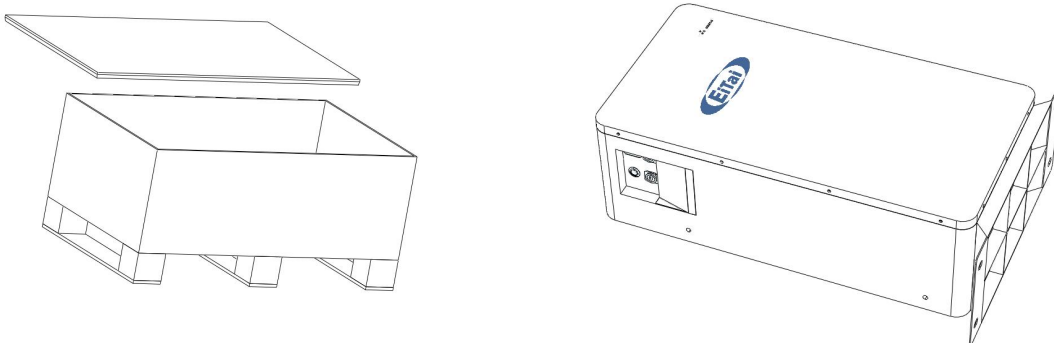

ELESHELL-14.3/16K					
No	Name	Model	Unit	Qty	Mark
1.	Battery	ELESHELL14.3K	PCS	1	Based on order model
1.	Battery	ELESHELL16K	PCS	1	
2.	Base	ELESHELL-14.3/16K-01-08	PCS	1	
3.	Cross outer hexagon triple combination bolt	M8*16	PCS	6	
4.	Internal expansion screw	M10*80	PCS	4	
5.	RS232-USB Cable	USB to 9PIN	SETS	1	
		9PIN to 8PIN			
6.	Connector	200A, Orange +, Black -	SETS	1	
7.	Extra soft silicone wire	2AWG, black, 1.5M	PCS	1	For inverter connection
		2AWG, red, 1.5M	PCS	1	
8.	Network through-head	1 to 2	PCS	1	
9.	OT cord end terminal	25-10	PCS	2	
10.	Heat shrinkable tube	Ø12 (40mm)	PCS	2	
11.	Communication cable	1+1 Crystal head/1.5m	PCS	1	
		Network cable 1m	PCS	1	
		1+1 Crystal head /0.2m	PCS	1	
12.	Crystal head	8P/ gilding 3U	PCS	2	
13.	Moving wheel		PCS	4	
14.	Built-in WIFI module		PCS	1	Optional
15.	User manual	ELESHELL-14.3/16K manual	PCS	1	
16.	Marks	QC	PCS	1	
		PASS	PCS	1	
		S/N	PCS	1	
		Mark	PCS	1	

Manufacturing instructions for power cable terminals:

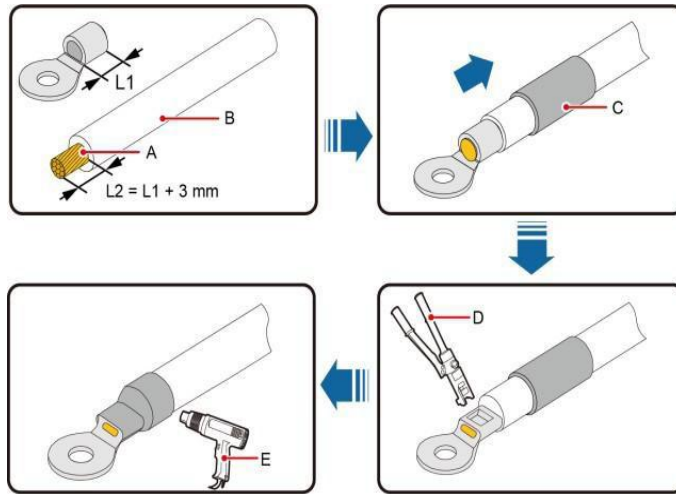



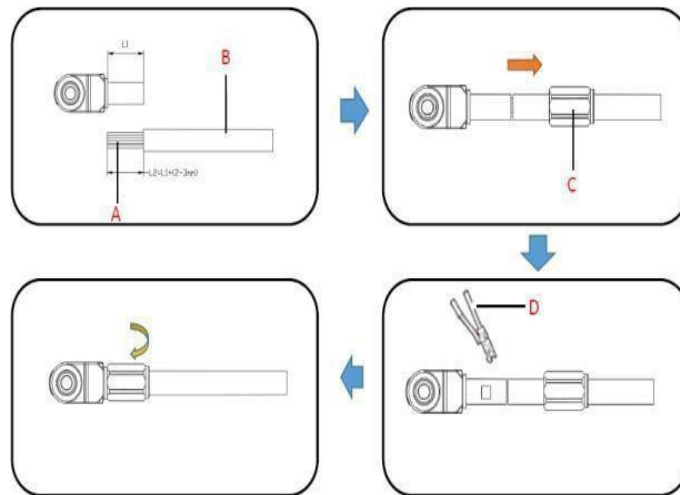





- (A) Copper Core Line
- (B) Insulation layer
- (C) Heat-shrink tube
- (D) Hydraulic pliers
- (E) Hot-air gun

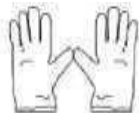

- (A) Copper Core Line
- (B) Insulation layer
- (C) Protective cover
- (D) Hydraulic pliers

6.2 Tools

Type	Tools		
Installation tools	<p>Knife</p> 	<p>Hammer drill</p> 	<p>Socket wrench</p> 
	<p>Rubber mallet</p> 	<p>Cross screwdriver</p> 	
	<p>Inclinometer</p> 	<p>Measuring tape</p> 	
Protective equipments	<p>ESD gloves</p> 	<p>Safety goggles</p> 	<p>Anti-dust respirator</p>
	<p>Safety shoes</p> 		

6.3 Installation Requirements

6.3.1 Installation Environment Requirements

1. Install the battery in an indoor environment;
2. Place the battery in a safe position away from children and animals;
3. Do not place the battery near any heat source, and avoid generating sparks;
4. Do not expose the battery to moist air or liquid;
5. Do not expose the battery to direct sunlight;
6. Do not expose the battery to a combustible gas or liquid.

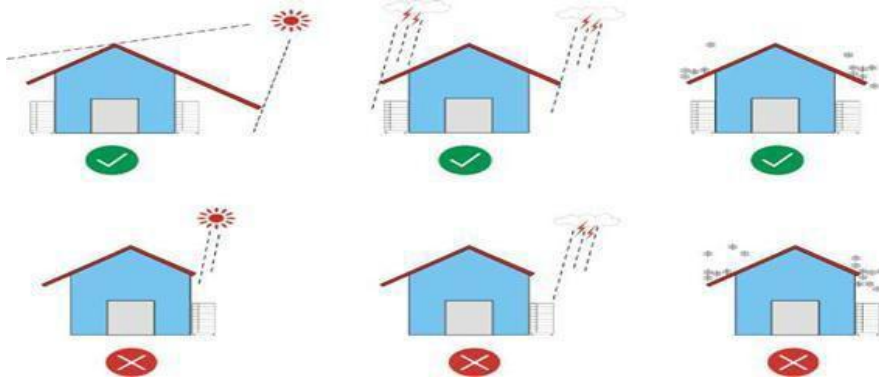

6.3.2 Installation Carrier Requirements

1. The mounting carrier shall be fire resistant. Do not install batteries on flammable buildings.
2. The mounting bracket surface shall meet the requirements of bearing requirements.



6.4 Installation Instructions

6.4.1 Overall Dimensions

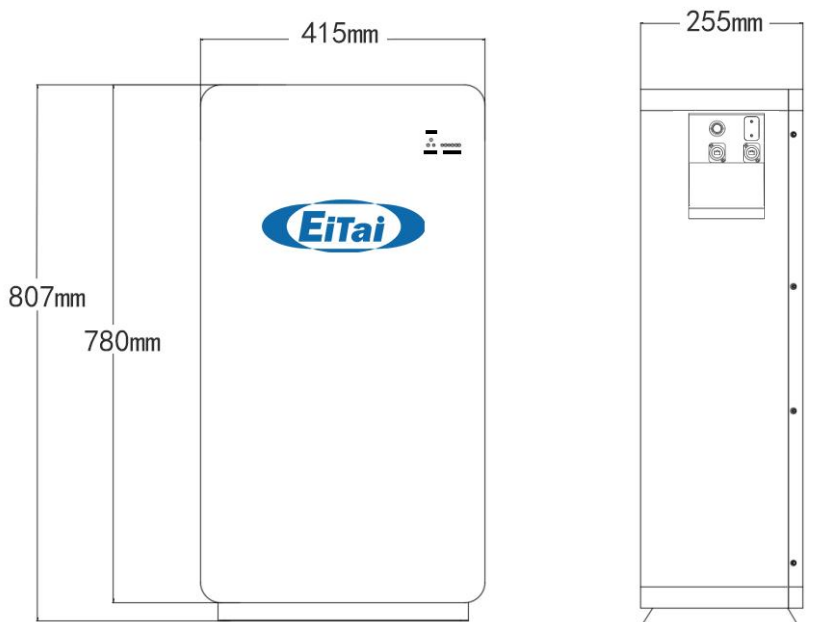

Minimum Installation distance between the battery pack and equipment:

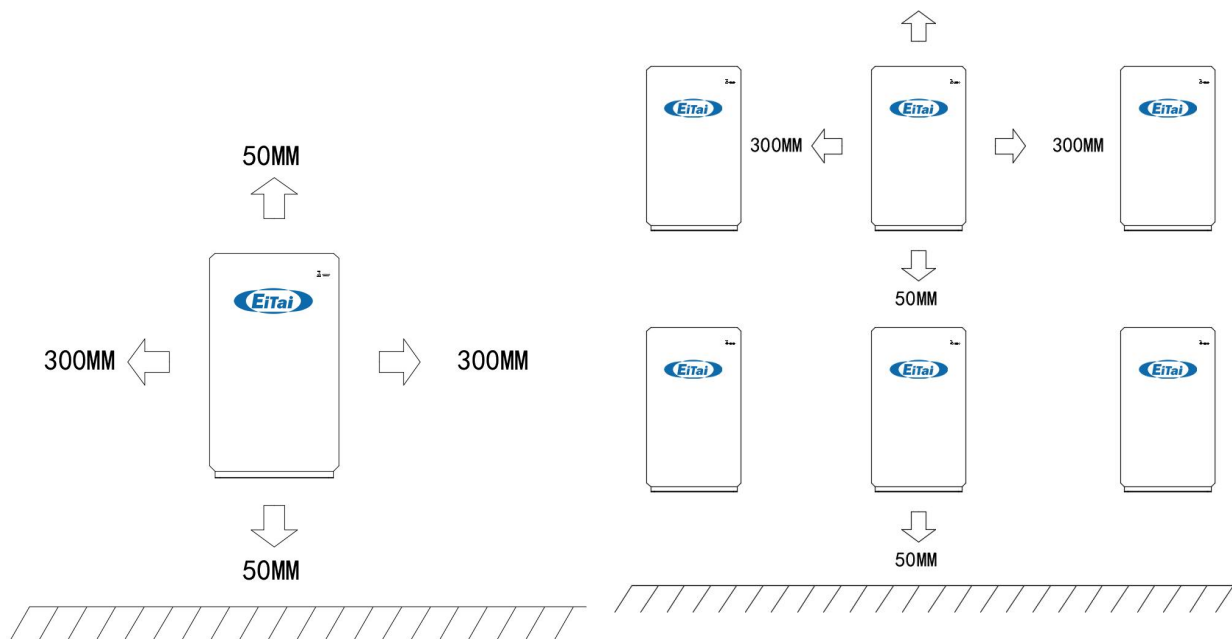

6.4.2 Connection of All Wires

Step 1: Fix the battery

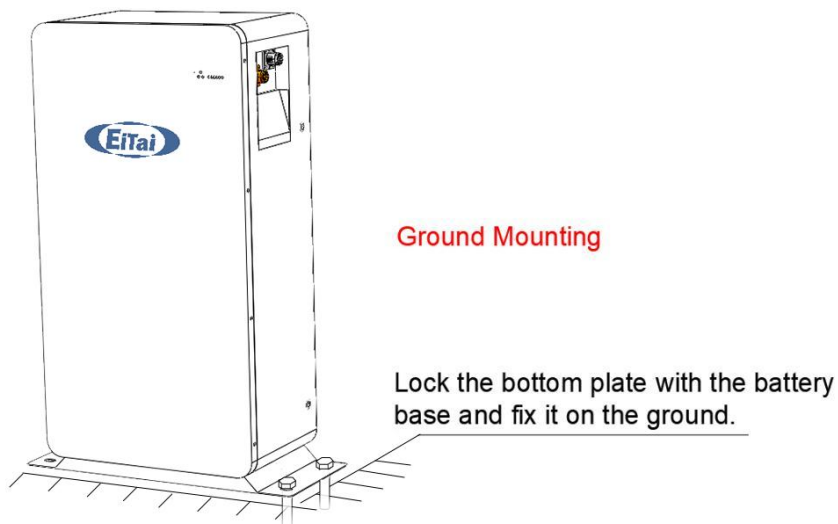

Step 2: Connect the power cable

(Ensure that the voltage difference between parallel batteries is within 1V.)

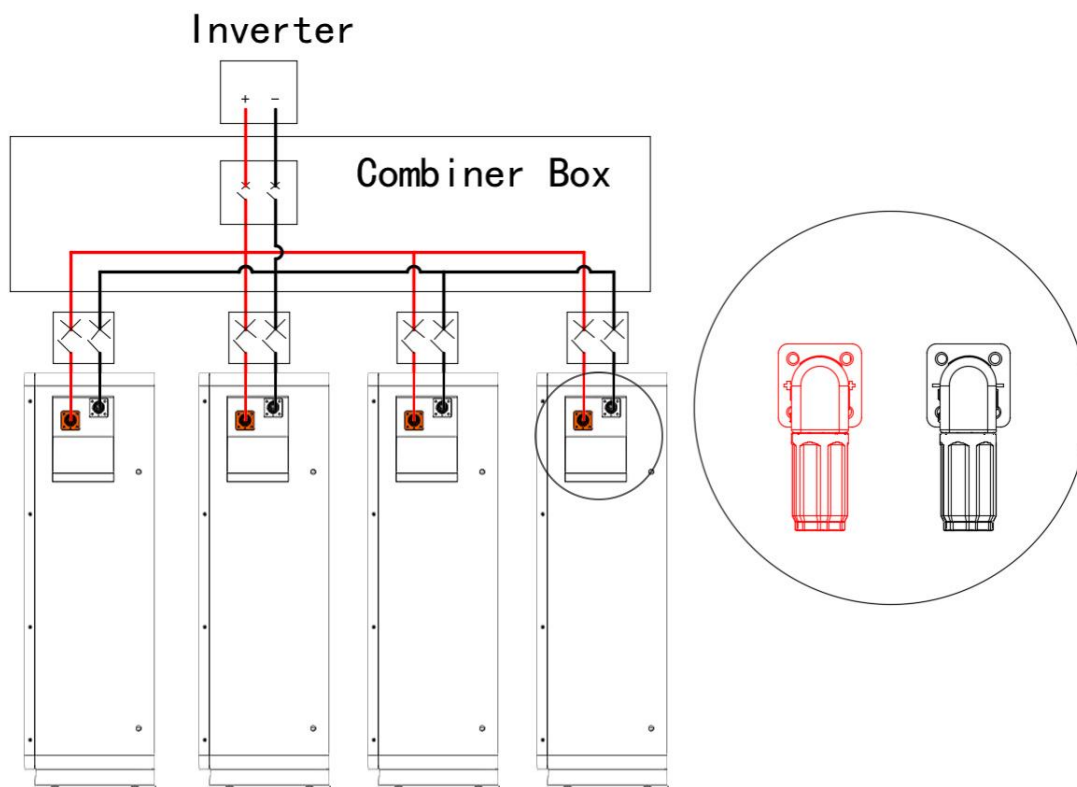

Step 3: Connect the internal communication line

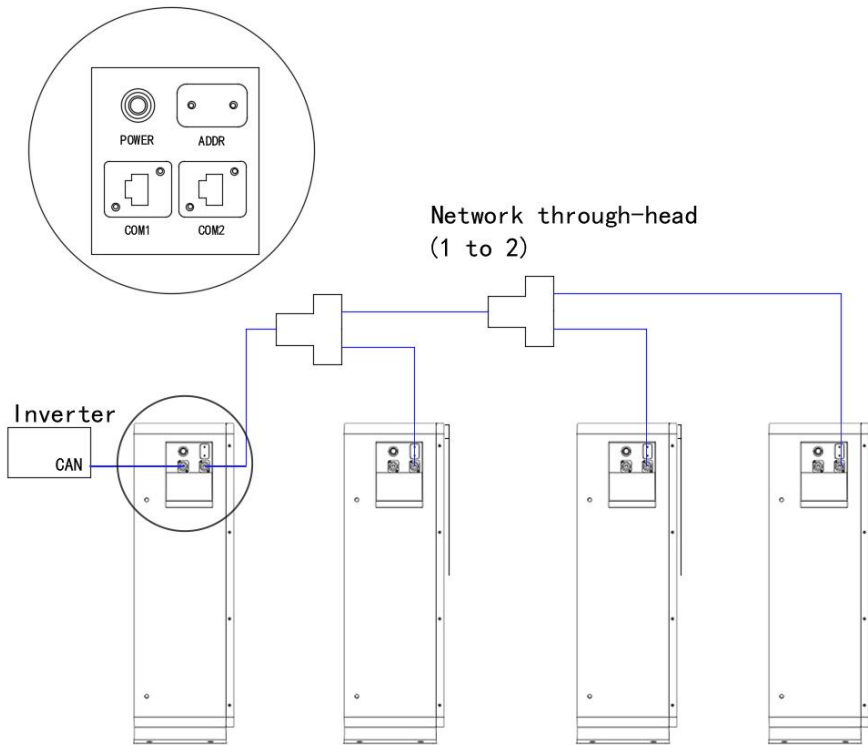

Step 4: Set BMS communication address

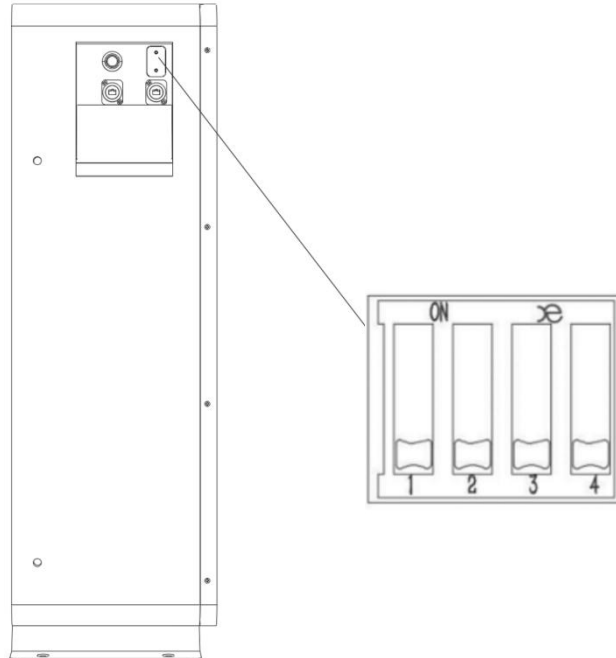

Please refer to 5.2.3: the dialing rule is to set the battery module address in sequence.

Step 5: Connect the built-in wifi module (optional)

After downloading the monitoring software, you can choose between Bluetooth connection and wifi binding. After binding to wifi, you can remotely monitor, modify parameters, and upgrade programs.

If there is an optional wifi module, please refer to the attached wifi manual for specific connection settings.

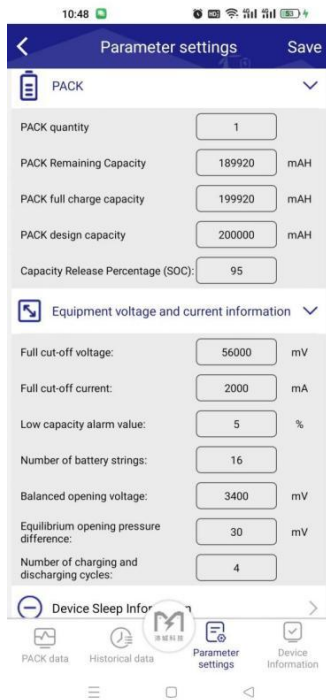

7 Cleaning and Maintenance

7.1 Cleaning Work

Please note: please turn off the power supply of the system before cleaning. It is recommended to clean battery regularly. If the shell is dirty, please use a soft and dry brush or dust collector to remove the dust. Do not use solvents, or corrosive liquids to clean the enclosure.

7.2 Maintenance

7.2.1 Recharging Requirements During Normal Storage

The battery shall be stored in an environment with a temperature range of $-10^{\circ}\text{C} \sim 45^{\circ}\text{C}$ and shall be maintained regularly according to the following table to 0.5C current is charged until 40%SOC after long storage.

Charging conditions during storage.

Store the ambient temperature	Relative humidity of the storage environment	Storage time	SOC
Below- 10°C		Prohibit	/
$-10\sim 25^{\circ}\text{C}$	5%~70%	≤ 12 months	$30\%\leq\text{soc}\leq 60\%$
$25\sim 35^{\circ}\text{C}$	5%~70%	≤ 6 months	$30\%\leq\text{soc}\leq 60\%$
$35\sim 45^{\circ}\text{C}$	5%~70%	≤ 3 months	$30\%\leq\text{soc}\leq 60\%$
Above 45°C		Prohibit	

7.2.2 Recharging Requirements for Excessive Discharge

Charge the over-discharge (90%DOD) battery within the time of meeting the table below, otherwise the over-discharge battery module will be damaged. Charging requirements for excessive battery discharge.

Storage environment temperature	Storage time	Note:
-10~25°C	≤ on Day 15	The battery pack disconnected to PCS
25~45°C	≤ on Day 7	
-10~45°C	<for 12 hours	Battery pack connect to the inverter

8 Common Issues and Solutions

8.1 Common Issues and Solutions

The user can monitor the operating status, warning, and alarm information through the inverter LCD display.

1. The battery cannot be turned on, and the LED indicator lights all turn off the battery depth discharge and requires charging first. If the external charger supply voltage is 51V or above and the battery still cannot be opened, contact EITAI.

2. The battery can be turned on but not charged or discharge If a red light indicates a system abnormality, check the following values:

1) Temperature: Above 60°C or below 0°C, the battery protection turns on, cannot charge.

Solution: Move the battery to normal operating temperature range between 0°C to 60°C.

2) Temperature: above 60°C or below -20°C, the battery cannot discharge.

Solution: Move the battery to normal operating temperature range between -20°C to 60°C.

3) Current: if current is greater than 200A, the battery protection turns on.

Solution: Stop using electrical appliances that exceed the maximum battery power load.

4) High voltage: If the battery voltage is above 57.9V or above, battery charging protection turns on.

Solution: The inverter will stop charging the battery if it sets the intelligent LI mode or a reasonable charging voltage.

5) Low voltage: The battery discharge protection turns on when the battery discharge to 46.4V or lower.

Solution: Charge the battery until the red light is off.

Excluding the above five points, if the fault cannot be found, turn off the battery and contact EITAI.

3. In multiple battery parallel systems, the SOC LED are different. Before installing batteries in parallel, measure the voltage of each battery to ensure that the voltage difference of each battery is within 1V.

- 1) When the first installation, please charge in full first to balance the capacity gap;

- 2) If the minimum SOC LED indicator is different less than 1 of the maximum SOC LED indicator, the SOC LED indicator is restored within 10 minutes in normal operation;

- 3) Before expanding the battery capacity, charge the online battery to 45%-50% SOC. After expanding the capacity, charge the battery system to balance the capacity gap. Ensure that the capacity difference before the parallel does not exceed 10%. If the capacity gap is large, it will take about two cycles to balance the capacity gap. The actual balance time depends on the capacity difference and the charge and discharge current.

Excluding the above three points, if the SOC display still fails, contact EITAI.

8.2 Emergency

Please cut off the power supply and turn off the battery in an emergency.

1. If the battery pack is damp or immersed in water, do not get close to the battery, and then contact EITAI or an authorized dealer for technical support.
2. Do not use water to fire when a fire! Only dry powder extinguishers; place the battery pack in a safe area if possible.
3. Battery leaking the electrolyte If the battery pack leaks the electrolyte, avoid contact with leaking liquid or gas.

If someone is exposed to the leaking material, do the following immediately.

Inhalation: evacuate the contaminated areas and seek medical treatment.

Contact eye: Rinse eyes with running water for 15 minutes and seek medical treatment.

Contact skin: Wash the infected site with soap and water and seek medical treatment.

Swallow in: urge vomiting, and seek medical treatment.

Battery damage: Damaged battery is dangerous and must be treated with very carefully. Battery cannot be used or may be dangerous to person or property. If the battery pack is damaged, contact EITAI for handling.

8.3 Handling of the Battery System

- 1) The system treatment must comply with the locally applicable disposal regulations of electronic waste and second-hand batteries.
- 2) Do not treat the battery system along with household waste.
- 3) Avoid exposing the battery to high heat or direct sunlight.
- 4) Avoid exposing the battery to high humidity or corrosive environments.
- 5) Do not expose the battery to a combustible gas or liquid.



Eitai (Xiamen) New Energy Technology Co.,Ltd.

**Add: Unit 2101 NO.8, Chengyi North Street, Software Park Phase III,
High-tech Zone, Xiamen City, China**