



**ELECUBE-5K
/ WALV-10K
User Manual**

Model

ELECUBE-5K / WALV-10K

Light up every corner of the world with renewable energy.

Contents

1 General Information	3
1.1 Validity	3
1.2 Intended Use	3
1.3 Product Identification	4
2 Safety Measures	5
3 Technical Parameters	6
4 Technical Items	7
5 Product Overview	7
5.1 Brief Introduction	7
5.2 Hardware and Instructions	8
5.2.1 Start Button	8
5.2.2 Dip Switch Definition	8
5.2.3 RS485-1/CAN Inverter Communication Port	9
5.2.4 RS232 Upper Computer Read Port	9
5.2.5 RS485-2 Battery Parallel Communication Port	10
5.3 LED Display Description	10
5.3.1 Enter Setting Page	10
5.3.2 Check Voltage Information of Each Cell	11
5.3.3 Communication Protocol Setting and Adjusting	11
5.3.4 Alarm Warning Information	12
6 Installation Guide	13
6.1 Inspection Before Installation	14
6.1.1 Check the Outer Packaging	14
6.1.2 Check Whether the Accessories are Complete	14
6.2 Tools	16
6.3 Installation Requirements	17
6.3.1 Installation Environment Requirements	17
6.3.2 Installation Carrier Requirements	18
6.4 Installation Instructions	18
6.4.1 Overall Dimensions	18
6.4.2 Minimum Installation Distance Between the Battery Pack and Equipment	19
6.4.3 Fix the Battery	19
6.4.4 Connect the Power Cable	20
6.4.5 Connect the Internal Communication Line	20



6.4.6 Set BMS Communication Address	21
6.4.7 Connect the Built-in Wifi Module (Optional)	21
7 Cleaning and Maintenance	22
7.1 Cleaning Work	22
7.2 Maintenance	22
7.2.1 Recharging Requirements During Normal Storage	22
7.2.2 Recharging Requirements for Excessive Discharge	23
8 Common Issues and Solutions	24
8.1 Common Issues and Solutions	24
8.2 Emergency	25
8.3 Handling of the Battery System	25

1 General Information

This manual introduces the **ELECUBE-5K / WALV-10K** battery products. Please read this manual carefully before using the battery. For any questions, please contact EITAI immediately for advice and clarification.

1.1 Validity

This user manual is applicable to **ELECUBE-5K / WALV-10K**.

This manual contains **ELECUBE-5K / WALV-10K** information, usage, guidance, safety information, installation guide and details on common operation issues and subsequent maintenance measures.

1.2 Intended Use

ELECUBE-5K / WALV-10K is an energy storage unit, that is designed for residential application scenarios with the capability of short-term backup.

Notes:

ELECUBE-5K / WALV-10K is not suitable for supporting life-sustaining medical devices. This product is intended for use only in accordance with the information provided in the enclosed documents and applicable local standards and regulations. Any other use may result in personal injury or property damage. The illustrations in this manual are only intended to help explain the concept of the system configuration, including use guidelines, safety precautions, common operating problems, and subsequent battery maintenance.

Alterations to the product, e.g. changes or modifications, are only permitted with the express written permission of EITAI. Unauthorized changes will not be allowed by warranty claims. EITAI shall not be liable for any damage resulting from such changes. Any use of the product other than described in the intended use section does not qualify as appropriate. The enclosed documentation is an integral part of this product. Please keep the documentation in a safe and convenient place for future reference.

Product model labels (see Section 1.3) must be attached to the product.

1.3 Product Identification

The type labels were attached on the product, which contain the product identification information. For safe usage, the user must be well-informed of the contents in the type labels.

The Labels include:

	Lithium-ion Battery Pack
Model:	ELECUBE-5K
Ratings:	5120Wh/51.2V/100Ah
Charge Voltage:	57.9V
Max.Output Power:	2.56KW
Maximum Discharge Current:	50A
Manufacturer:	EiTai
Eitai (Xiamen) New Energy Technology Co., Ltd.	
Unit 2101 NO.8, Chengyi North Street, Software Park Phase III, High-tech Zone, Xiamen City, China	
<p>CAUTION!</p> <ul style="list-style-type: none"> Do not disassemble Do not short-circuit Do not place in fire or near hot source Please read user manual carefully 	
CE, IEC62619, MSDS, ROHS, UN38.3	

	Secondary Li-ion Battery
Model:	WALV-10K
Ratings:	10240Wh/51.2V/200Ah
Charge Voltage:	57.9V
Max.Output Power:	6.14KW
Maximum Discharge Current:	120A
Manufacturer:	EiTai
Eitai (Xiamen) New Energy Technology Co., Ltd.	
Unit 2101 NO.8, Chengyi North Street, Software Park Phase III, High-tech Zone, Xiamen City, China	
<p>CAUTION!</p> <ul style="list-style-type: none"> Do not disassemble Do not short-circuit Do not place in fire or near hot source Please read user manual carefully 	
CE, IEC62619, CB, MSDS, ROHS, UN38.3, JIS C 8715	



DANGER !
CHEMICAL HAZARD & SHOCK HAZARD

- Do not disassemble or repair by yourself.
- Do not drop, deform, impact, cut or spearing with a sharp object.
- Do not place near open flame or incinerate.
- Do not put any objects onto the battery.
- Do not allow to contact with liquid.
- Keep out of reach of children, animals or insects.
- Contact the supplier within 24 hours if anything wrong.

WARNING !

Stop the battery operation immediately to secure the battery safety when environmental temperature is over working temperature (suitable operation temperature is 0~45°C).
If battery is at high temperature usually, it will impact battery performance.

2 Safety Measures

This section contains safety information that must always be observed when using or installing batteries. To prevent personal injury or property damage and ensure long-term operation of the batteries, please read this section carefully, always watch for warnings   from all safety messages.

Environmental requirements:

1. Do not expose the battery to temperature above 50 °C;
2. Do not place the battery near any heat source;
3. Do not expose the battery to moisture or liquid;
4. Do not expose the battery to a corrosive gas or liquid;
5. Do not expose the battery to a combustible gas or liquid;
6. Do not expose the battery to direct sunlight for extended periods of time;
7. Battery power terminals are not allowed to contact conductive objects, such as electric wires;
8. Place the battery in safe place that away from children and animals.

Operation Precautions:

1. Do not disassemble the battery;
2. Do not touch the battery pack with wet hands;
3. Do not smash, fall, or puncture the battery;
4. Do not reverse the polar series connection battery;
5. Do not short-circuit the terminal, and remove all metal jewelry items that may produce a short-circuit before installation and repair;
6. Always handle the products in accordance with the local safety regulations;
7. Store and use the battery in the user's manual;
8. Ensure reliable grounding;
9. Disconnecting all batteries to the wires before installation and repair;
10. Do not stack batteries outside the protective packaging during storage or handling;
11. The stacking of packaging batteries shall not exceed the quantity specified on the packaging;
12. Continued operation of a damaged battery may lead to dangerous situations, causing serious injuries such as electric shock or combustion.

3 Technical Parameters

Basic Parameters	Technical Specification	
Model	ELEUCUBE-5K	WALV-10K
Battery Type	LiFePO4	LiFePO4
Nominal Capacity (Ah)	100Ah	200Ah
Nominal Voltage (V)	51.2V	51.2V
Total Energy (W.h)	5120W.h	10240W.h
Depth of Discharge (90%DOD)	4608W.h	9216W.h
Maximum Charging Voltage (V)	57.9V	57.9V
End of Voltage (V)	46.4V	46.4V
Maximum Current (A)	50A	120A
Maximum Power (W)	2560W	6144W
Working Humidity	≤95%rh	
Store Humidity	≤95%rh	
Working Altitude	≤2000m	
Maximum Number of Parallel	15 pcs	
Protection Level	IP65	
Net Weight (Kg)	58Kg	90Kg
Dimensions (mm)	420*674*173mm	421.6*635*259mm
Product Certificate	CE, IEC62619, MSDS, ROHS, UN38.3	CE, IEC62619, CB, MSDS, ROHS, UN38.3, JIS C 8715
Circle Life	≥6000 times	
Communication Port	CAN, RS485, RS232	
Operating Temperature	0℃ ~ 60℃	
Storage Temperature	≤25℃, 12 months;	
	≤35℃, 6 months;	
	≤45℃, 3months	

Note: Operating current derating according to the cell voltage and temperature.

4 Technical Items

No.	Name	Comment
1	Discharge	Battery output power for load
2	Charge	Put the electricity into the battery through the charger
3	Full charge	The battery is fully charged with 100% SOC
4	Standby	Ready for charging or discharging
5	Turn-off	Turn-off battery output
6	SOC	State of charging (Useable capacity)
7	Battery voltage	Voltage between the battery B+ /B -
8	Single-string voltage	Single-cell voltage
9	Alarm	Indicates that the battery is in an abnormal state
10	Protection	Battery stops charging or discharging
11	Fault	Battery or BMS is damaged and need to be replaced
12	Over discharged	Battery is lack of electricity, and need to be charged in time

5 Product Overview

5.1 Brief Introduction.

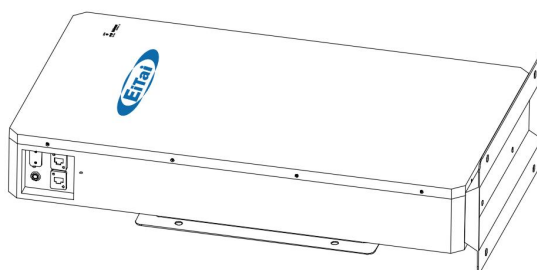

ELEUCUBE-5K / WALV-10K is a lithium battery energy storage system with an operating voltage range of between 46.4~57.9v, it is used for household energy storage applications, in cooperation with low voltage inverters to achieve home energy storage purpose.

ELEUCUBE-5K / WALV-10K has a built-in BMS (Battery Management System) which can manage and monitor cells information, including voltage, current and the temperature. In addition, the BMS can balances battery charging to extend lifespan.

BMS has the protections including over-discharge, overcharge, over-current, high / low temperature, etc.

The system can automatically manage the charging status, discharge state, balance state. Multiple batteries can be connected in parallel to expand storage capacity to meet larger capacity and continuous power support time, **ELECUBE-5K / WALV-10K** support up to 15 parallel operations.

5.2 Hardware and Instructions

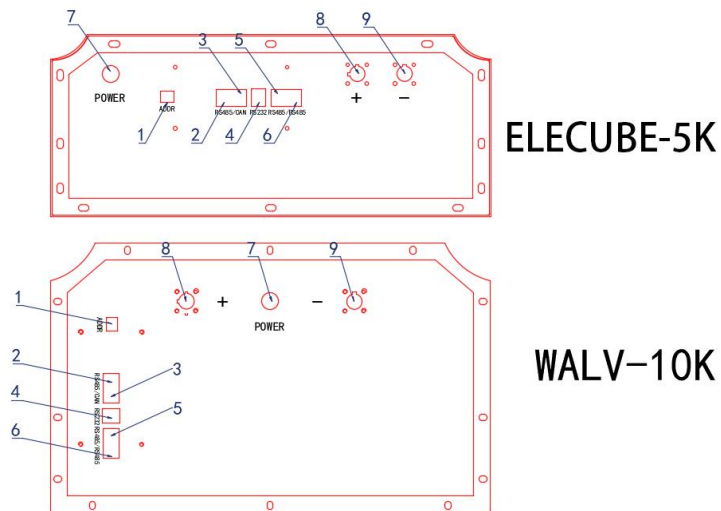

No.	Items	No.	Items
1	ADDR Dial address	2	RS485-1
3	CAN	4	RS232
5/6	RS485-2	7	Power switch
8	Battery positive pole	9	Battery negative pole

5.2.1 Start Button

Press the start button, release the button, and the button is locked.

5.2.2 Dip Switch Definition

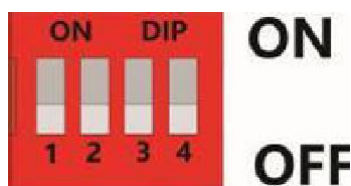

Schematic Diagram of the Dial-up Switch

The dial-dip switch is used to set the BMS address of each battery. The code value of the dial-ON position is 1, and the code value of the dial-1234 position is 0.

The host battery address is 1, and the slave battery address is 2 to 15. (The host is connected to the inverter, and the slave machines are arranged in numerical order according to the address)

The dial-up address table is as follows:

Dial-up code location					Add	Dial-up code location					Add	Dial-up code location					Add	Dial-up code location					Add	
#1	#2	#3	#4		#1	#2	#3	#4		#1	#2	#3	#4		#1	#2	#3	#4		#1	#2	#3	#4	
0	0	0	0	X	0	0	1	0	4	0	0	0	1	8	0	0	1	1	12					
1	0	0	0	1	1	0	1	0	5	1	0	0	1	9	1	0	1	1	13					
0	1	0	0	2	0	1	1	0	6	0	1	0	1	10	0	1	1	1	14					
1	1	0	0	3	1	1	1	0	7	1	1	0	1	11	1	1	1	1	15					

5.2.3 RS485-1/CAN Inverter Communication Port



	Definition Description		Definition Description		Definition Description		Definition Description
PIN1	RS485-B	PIN5	/	PIN1	/	PIN5	CAN-L
PIN2	RS485-A	PIN6	/	PIN2	/	PIN6	/
PIN3	/	PIN7	RS485-A	PIN3	/	PIN7	/
PIN4	/	PIN8	RS485-B	PIN4	CAN-H	PIN8	/

The communication terminal (RJ45 port) follows CAN / RS485 protocol, and is connected to the inverter BMS for communication.

The BMS controls the charging current/charging voltage or discharge current/discharge cut-off voltage of the inverter based on the battery voltage and battery temperature through CAN/RS485 communication.

5.2.4 RS232 Upper Computer Read Port

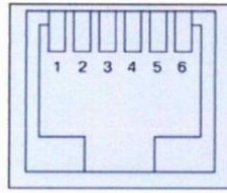

	Definition Description		Definition Description
PIN1	/	PIN4	RX
PIN2	/	PIN5	GND
PIN3	TX	PIN6	/

RS232 communication port follows RS232 protocol, allows upper computer read port to read, and modify the battery spec.

5.2.5 RS485-2 Battery Parallel Communication Port

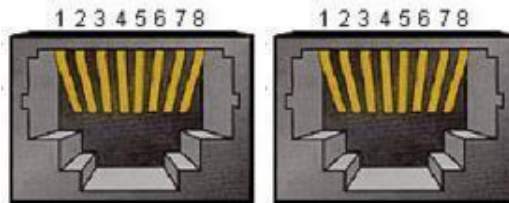

	Definition Description		Definition Description
PIN1	RS485-B	PIN5	/
PIN2	RS485-A	PIN6	/
PIN3	/	PIN7	RS485-A
PIN4	/	PIN8	RS485-B

5.3 LED Display Description

5.3.1 Enter Setting Page



The main screen displays the total battery voltage and real-time current. Click the gear in the upper right corner to enter the Settings and information interface.

5.3.2 Check Voltage Information of Each Cell

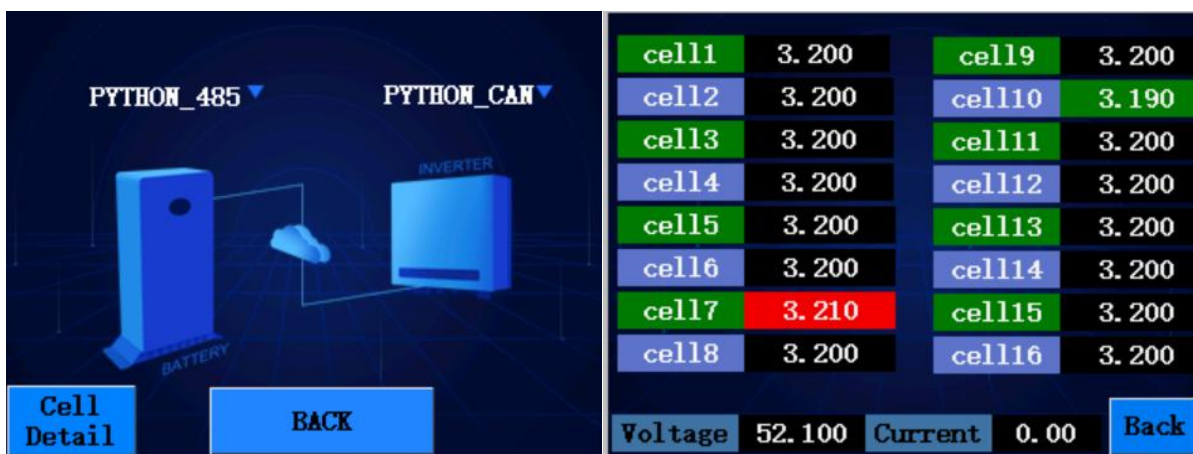

Click "Cell Detail" to enter the voltage information of each cell; click "Back" to return back to the main screen.

- 1) Respectively in the figure shows the single section of 16 series of batteries batteries voltage.
- 2) In green (3.190mv) shows the minimum voltage of cell, and is cell 10.
- 3) Figure in red (3.210mv) shows the highest voltage of cell, and is cell 7.
- 4) Voltage shows the values for the total voltage, Current shows the real time current.
- 5) Click "Back" to return to the interface of information.

5.3.3 Communication Protocol Setting and Adjusting



- 1) Click PYTHON - 485 can choose 485 communication protocol, and click SAVE to SAVE selection after entering 485 communication protocol, click CANCEL to CANCEL the choice.
- 2) PYTHON - CAN click CAN select the CAN communication protocol, click SAVE to SAVE selection after entering the CAN communication protocol, click CANCEL to CANCEL the choice.

5.3.4 Alarm Warning Information.

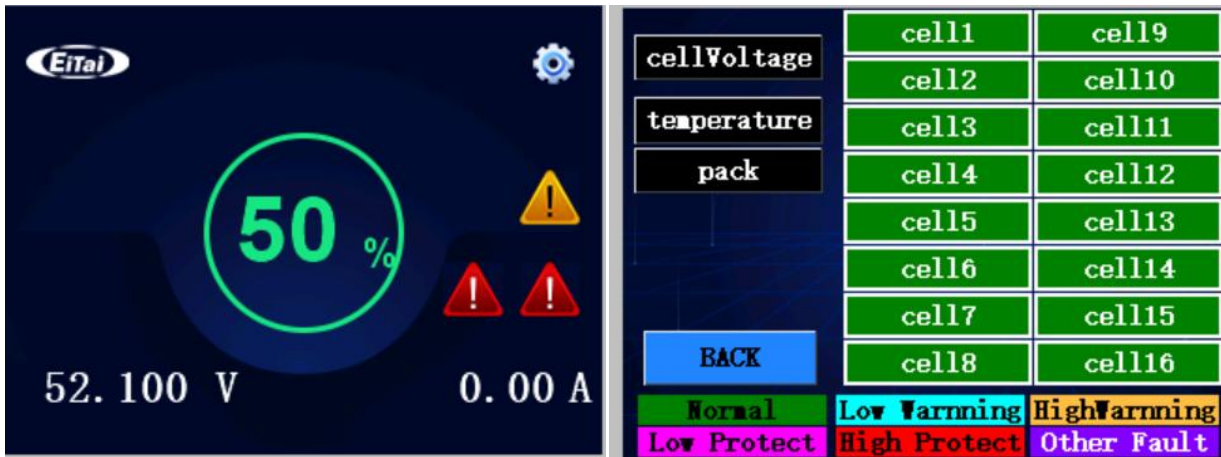

When an alarm is generated, an alarm icon is displayed on the home page. Click the icon to view alarm details.

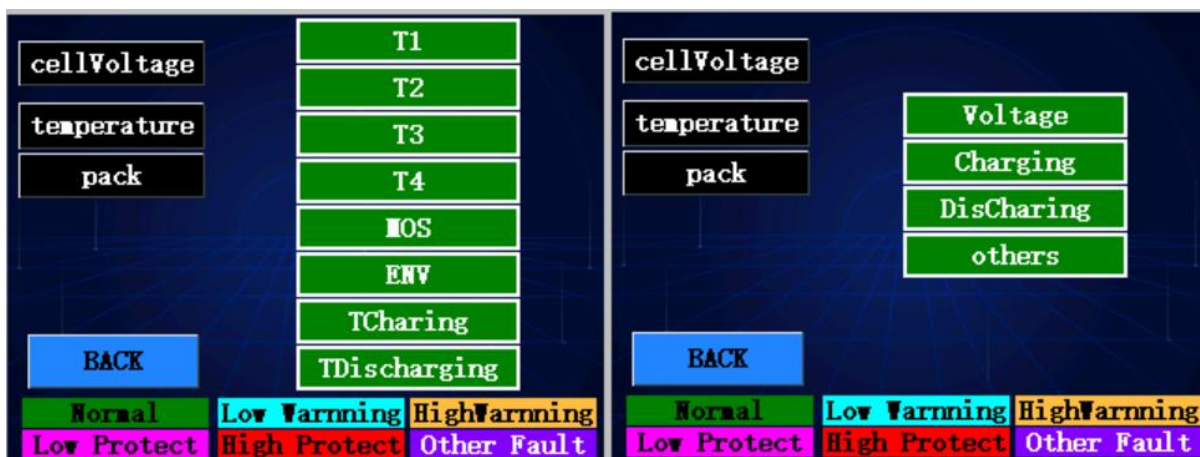

Name	Define
Cell Voltage	Cell voltage
Temperature	Cell temperature
Pack	Battery pack status
Normal	Normal
Low Warning	Low voltage warning
High Warning	Over voltage warning
Low Protect	Low voltage protection
High Protect	Over voltage protection
Other Fault	Others

6 Installation Guide

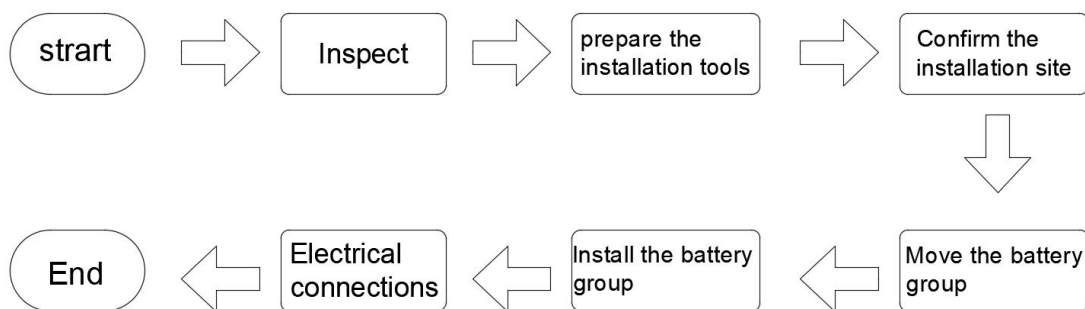

Installation flow chart

6.1 Inspection Before Installation

6.1.1 Check the Outer Packaging

Packaging materials and components may be damaged during transportation. Therefore, please check the packaging material before installing the battery. Check the surface of packaging materials for damage, such as holes and cracks. If any damage is found, do not unpack the battery and contact the dealer as soon as possible. It is recommended that you remove the packaging material within 24 hours before installing the battery.

6.1.2 Check Whether the Accessories are Complete

After opening the packing box, check whether the attached accessories are complete. If any damage or missing parts are found, contact your dealer.

Accessories list in the package

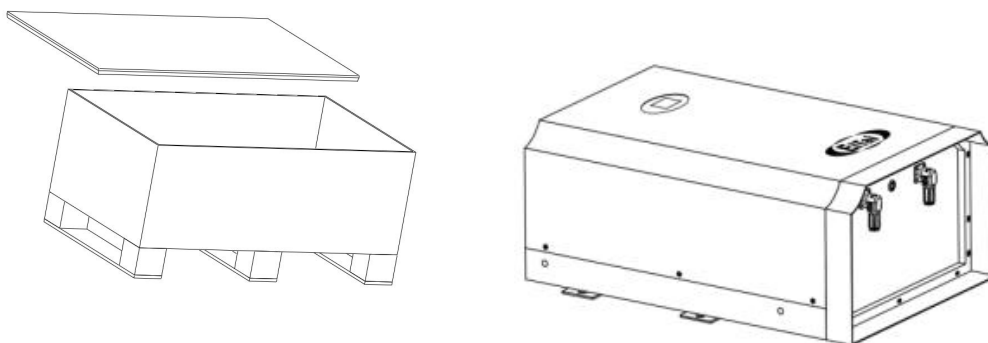

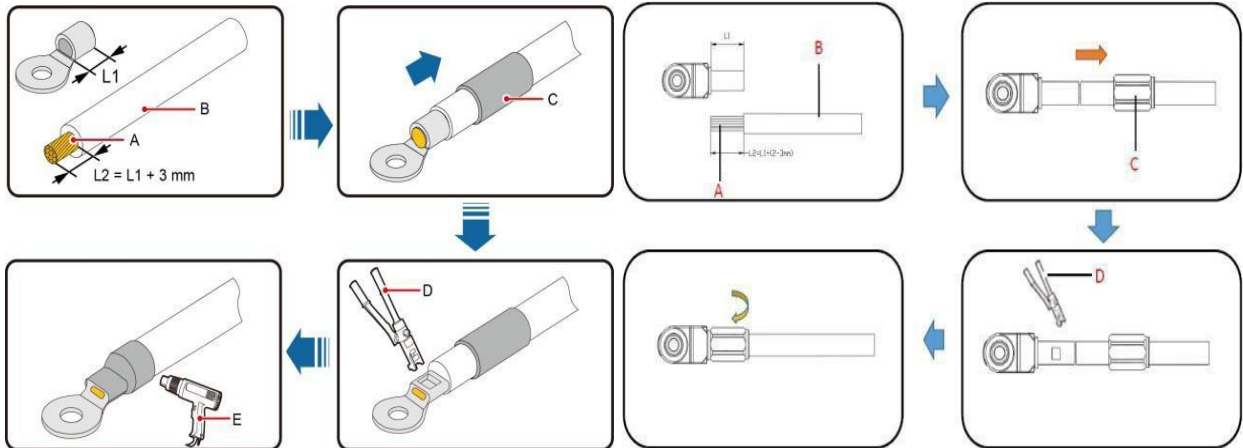

ELECUBE-5K / WALV-10K					
No.	Name	Model	Unit	Qty	Mark
1	Battery	ELECUBE-5K	PCS	1	Based on order model
1	Battery	WALV-10K	PCS	1	
2	Wall-hanging	Steel	SETS	1	
3	Positioning paper case		PCS	1	
4	Internal expansion screw	M10*80	PCS	4	
5	Base	Steel	SETS	1	
6	Cross outer hexagon triple combination bolt	M8*16	PCS	4	Only for WALV-10K
7	RS232-USB cable	USB to 9PIN	SETS	1	For information reading
		9PIN to 6PIN			
8	Connector	125A Orange +, Black -	SETS	1	
9	Extra soft silicone wire	4AWG (black) 1.5M	PCS	1	For inverter connection
		4AWG (red) 1.5M	PCS	1	
10	OT cord end terminal	25-10	PCS	2	
11	Heat shrinkable tube	Ø12 (40mm)	PCS	2	
12	Communication cable	1+1 crystal head/1.5m	PCS	1	Communication
		Network cable 1m	PCS	1	Back-up
		1+1 crystal head /0.2m	PCS	1	For parallel communication
13	Crystal head	8P/ gilding 3U	PCS	2	Back-up
14	Built-in WIFI module		PCS	1	Optional
15	User manual	ELECUBE-5K/WALV-10K manual	PCS	1	
16	Marks	QC	PCS	1	
		PASS	PCS	1	
		S/N	PCS	1	
		Mark	PCS	1	

Manufacturing instructions for power cable terminals:

(A) Copper core line	(B) Insulation layer	(C) Heat-shrink tube		(A) Copper core line	(B) Insulation layer
(D) Hydraulic pliers	(E) Hot-air gun			(C) Protective cover	(D) Hydraulic pliers

6.2 Tools

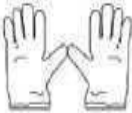
Type	Tools		
Installation tools	Knife 	Hammer drill 	Socket wrench
	Rubber mallet 	Cross screwdriver 	
	Inclinometer 	Measuring tape 	

Protective equipments	ESD gloves 	Safety goggles 	Anti-dust respirator
	Safety shoes 		

6.3 Installation Requirements

6.3.1 Installation Environment Requirements

1. Install the battery in an indoor environment.
2. Place the battery in a safe position away from children and animals.
3. Do not place the battery near any heat source, and avoid generating sparks.
4. Do not expose the battery to moist air or liquid.
5. Do not expose the battery to direct sunlight.
6. Do not expose the battery to a combustible gas or liquid.

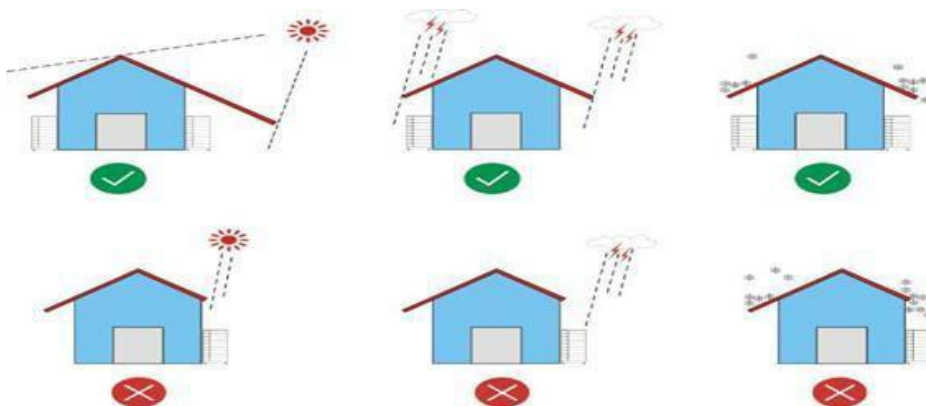

6.3.2 Installation Carrier Requirements

1. The mounting carrier shall be fire resistant. Do not install batteries on flammable buildings.
2. The mounting bracket surface shall meet the requirements of bearing requirements.



6.4 Installation Instructions

6.4.1 Overall Dimensions

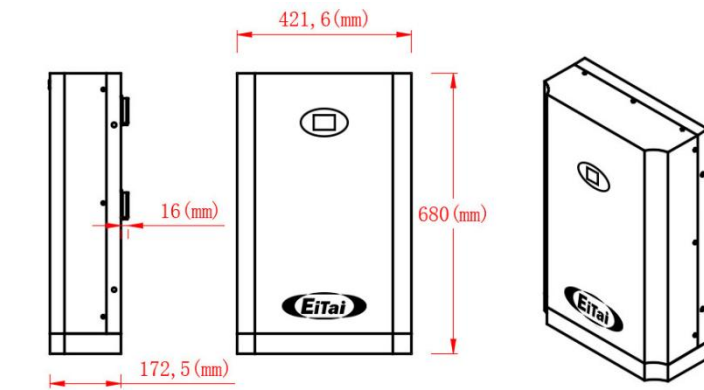

ELECUBE-5K

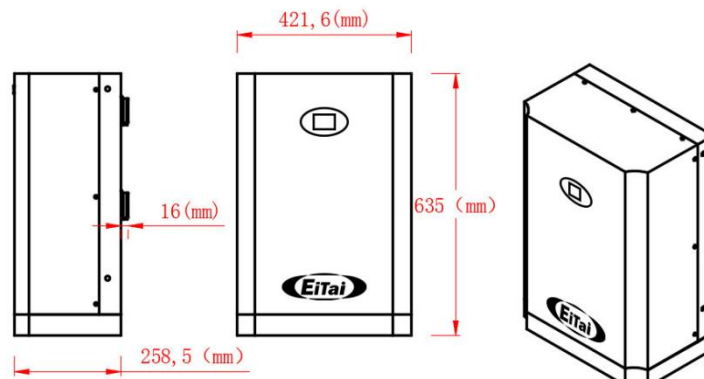

WALV-10K

6.4.2 Minimum Installation Distance Between the Battery Pack and Equipment

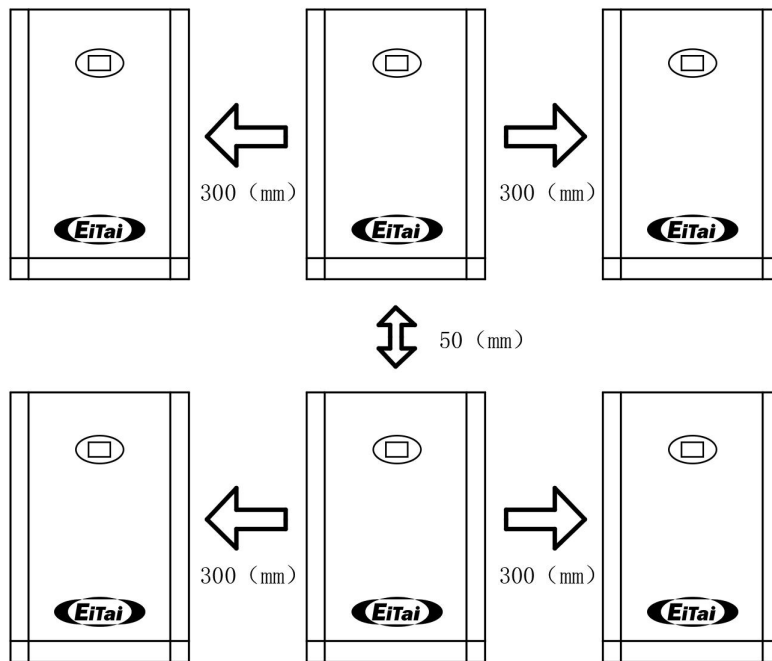

6.4.3 Fix the Battery

1. Wall Mounted Installation: Drill 16mm holes on the wall using a $\Phi 16$ drill bit according to the size, and fix the wall hanging.

There is a positioning board attached to the packing box. Mark it for drilling and lock the inner expansion screws to fix the wall hanging plate.

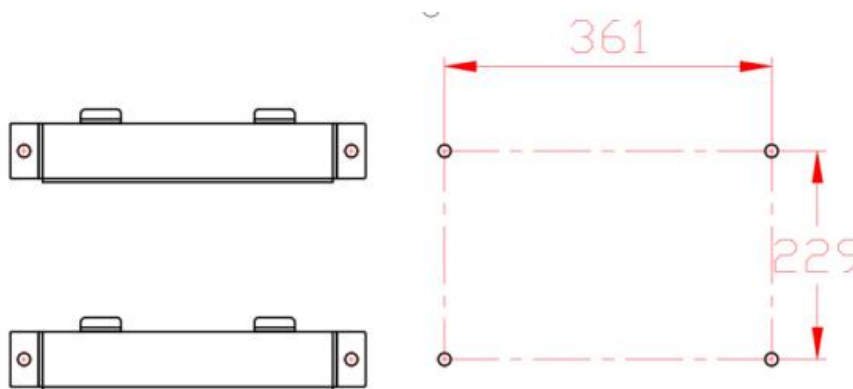

2. Ground Mounted Installation:

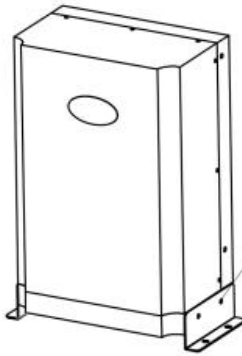

Use cross over hexagon bolts M8*16 to fix the base with the battery box;
Use internal expansion screw M10*80 to fix with ground.

Note: Ground installation only for model WALV-10K

6.4.4 Connect the Power Cable

(Ensure that the voltage difference between parallel batteries is within 1V)

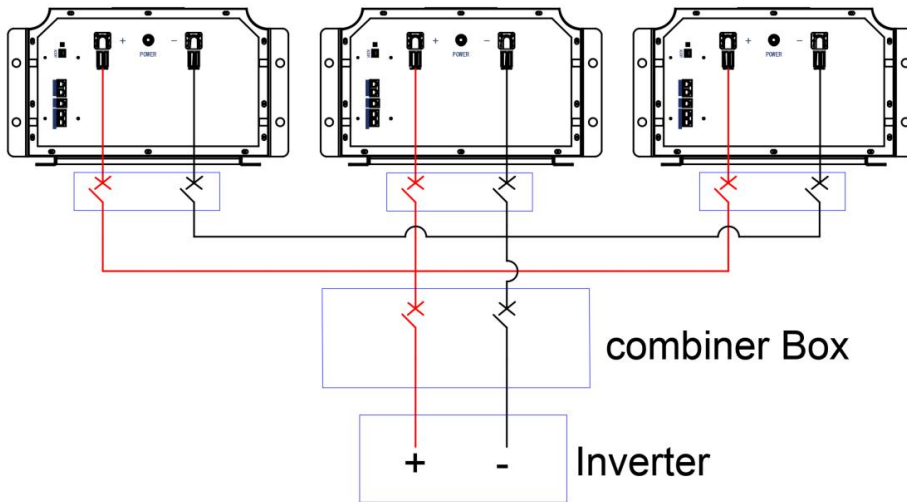

6.4.5 Connect the Internal Communication Line

(Choose RS485-1/ CAN according to the inverter.)

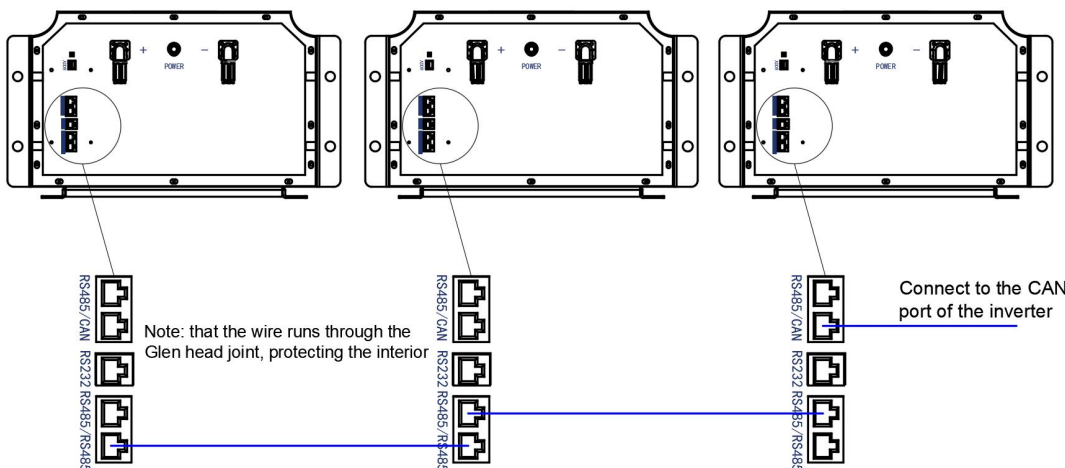

6.4.6 Set BMS Communication Address

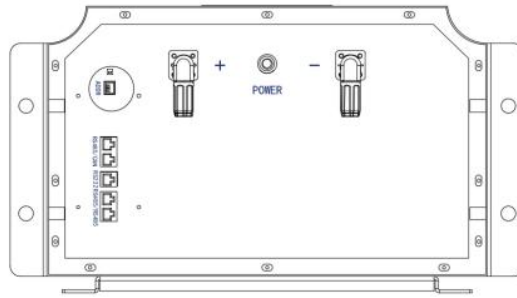

Please refer to 5.2.2: the dialing rule is to set the battery module address in sequence.

6.4.7 Connect the Built-in Wifi Module (Optional)

After downloading the monitoring software, you can choose between Bluetooth connection and wifi binding. After binding to wifi, you can remotely monitor, modify parameters, and upgrade programs.

If there is an optional wifi module, please refer to the attached wifi manual for specific connection settings.

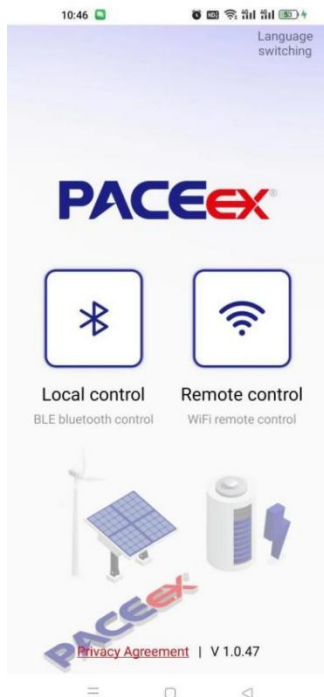

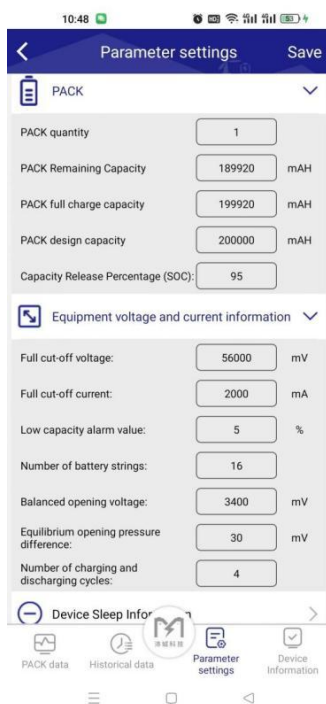

7 Cleaning and Maintenance

7.1 Cleaning Work

Please note: please turn off the power supply of the system before cleaning. It is recommended to clean battery regularly. If the shell is dirty, please use a soft and dry brush or dust collector to remove the dust. Do not use solvents, or corrosive liquids to clean the enclosure.

7.2 Maintenance

7.2.1 Recharging Requirements During Normal Storage

The battery shall be stored in an environment with a temperature range of -10°C~45°C and shall be maintained regularly according to the following table to 0.5C current is charged until 40%SOC after long storage.

Charging conditions during storage

Store the ambient temperature	Relative humidity of the storage environment	Storage time	SOC
Below-10℃		Prohibit	/
-10~25℃	5%~70%	≤ 12 months	30%≤soc≤60%
25~35℃	5%~70%	≤ 6 months	30%≤soc≤60%
35~45℃	5%~70%	≤ 3 months	30%≤soc≤60%
Above 45℃		Prohibit	

7.2.2 Recharging Requirements for Excessive Discharge

Charge the over-discharge (90%DOD) battery within the time of meeting the table below, otherwise the over-discharge battery module will be damaged. Charging requirements for excessive battery discharge

Storage environment temperature	Storage time	Note:
-10~25℃	≤ on Day 15	The battery pack disconnected to PCS, open battery with DC charger for charging.
25~45℃	≤ on Day 7	
-10~45℃	<for 12 hours	Battery pack connect to the Inverter, use PV or grid for charging.

8 Common Issues and Solutions

8.1 Common Issues and Solutions

The user can monitor the operating status, warning, and alarm information through the inverter LCD display.

1. The battery cannot be turned on, and the LED indicator lights all turn off the battery depth discharge and requires charging first. If the external charger supply voltage is 51V or above and the battery still cannot be opened, contact EITAI.

2. If the red light indicates system error, check the following values:

1) Temperature: Above 60°C or below 0°C, the battery protection turns on.

Solution: Move the battery to normal operating temperature range between 0°C to 60 °C.

2) Temperature: above 60°C or below -20°C, the battery cannot discharge.

Solution: Move the battery to normal operating temperature range between -20°C to 60 °C.

3) Current: if current is greater than 200A, the battery protection will turn on (ELECUBE -5K with 50A limitation).

Solution: Stop using electrical appliances that exceed the maximum battery power load.

4) High voltage: If the battery voltage is above 57.9v or above, battery charging protection turns on.

Solution: The inverter will stop charging the battery if it sets the intelligent LI mode or a reasonable charging voltage.

5) Low voltage: The battery discharge protection is turned on when the battery discharges to 46.4V or lower.

Solution: Charge the battery until the red light is off.

Excluding the above five points, if the fault cannot be found, turn off the battery and contact EITAI.

3. In multiple battery parallel systems, the SOC LED are different. Before installing batteries in parallel, measure the voltage of each battery to ensure that the voltage difference of each battery is within 1V.

1) When the first installation, please charge in full first to balance the capacity gap;

2) If the minimum SOC LED indicator is different less than 1 of the maximum SOC LED

indicator, the SOC LED indicator is restored within 10 minutes in normal operation;

3) Before expanding the battery capacity, charge the online battery to 45%-50% SOC. After expanding the capacity, charge the battery system to balance the capacity gap. Ensure that the capacity difference before the parallel does not exceed 10%. If the capacity gap is large, it will take about two cycles to balance the capacity gap. The actual balance time depends on the capacity difference and the charge and discharge current.

Excluding the above three points, if the SOC display still fails, contact EITAI.

8.2 Emergency

Please cut off the power supply and turn off the battery in an emergency.

1. If the battery pack is damp or immersed in water, do not get close to the battery, and then contact EITAI or an authorized dealer for technical support.
2. Do not use water to extinguish a fire! Only dry powder extinguishers; place the battery pack in a safe area if possible.
3. Battery leaking the electrolyte If the battery pack leaks the electrolyte, avoid contact with leaking liquid or gas.

If someone is exposed to the leaking material, do the following immediately.

Inhalation: evacuate the contaminated areas and seek medical treatment.

Contact eye: Rinse eyes with running water for 15 minutes and seek medical treatment.

Contact skin: Wash the infected site with soap and water and seek medical treatment.

Swallow in: urge vomiting, and seek medical treatment.

Battery damage: Damaged battery is dangerous and must be treated with very carefully. Battery cannot be used or may be dangerous to person or property. If the battery pack is damaged, contact EITAI for handling.

8.3 Handling of the Battery System

- 1) The system treatment must comply with the locally applicable disposal regulations of electronic waste and second-hand batteries.
- 2) Do not treat the battery system along with household waste.
- 3) Avoid exposing the battery to high heat or direct sunlight.
- 4) Avoid exposing the battery to high humidity or corrosive environments.
- 5) Do not expose the battery to a combustible gas or liquid.



Eitai (Xiamen) New Energy Technology Co.,Ltd.

**Add: Unit 2101 NO.8, Chengyi North Street, Software Park Phase III,
High-tech Zone, Xiamen City, China**