

REGULATING *Thermostat, Hygrostat*



JTO 011:

Thermostat (Normally Closed): Commonly used to connect heaters and disconnect the circuit when the temperature reaches the set value.

JTS 011:

Thermostat (Normally Open): Commonly used to monitor filter fans, heat exchangers, or close circuit output signals when the temperature exceeds the set value.

- Compact and space-saving design
- Long electrical service life
- Easy installation on 35mm DIN rail
- High switching performance
- Easy wiring and simple setup



JTO 011

JTS 011



SPECIFICATION

Model	JTO 011	JTS 011
Contact	NC	NO
Temperature	0°C~60°C	
Switching temperature difference	7k (± 4k tolerance)	
Sensing element	Bimetallic temperature sensing material	
Service life	>100000 cycles	
Maximum switching load	250VAC, 10A, 120VAC, 15A, DC15A	
Connection method	Screw Terminal	
Shell	UL94 V-0	
Install	Installation of 35mm DIN rail	
Size	64x33x44mm	
Weight	40g	



Connection Example

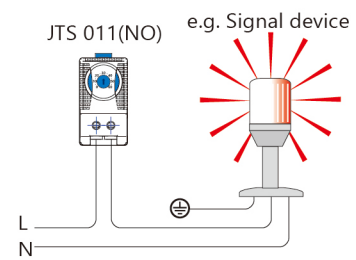
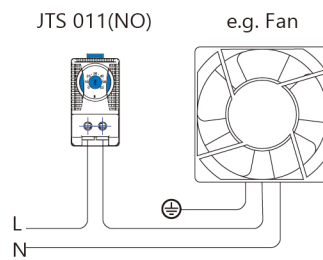
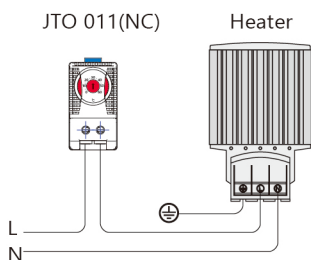

DIMENSION (mm)

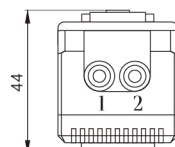
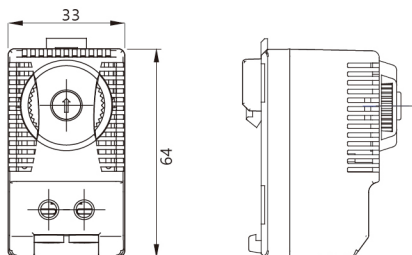

WIRING DIAGRAM

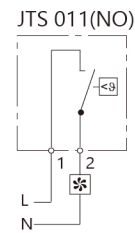
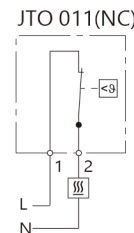

Heater Fan filter
Cooling equipment signal device

KTO 011/KTS 011 THERMOSTAT

KTO 011:

Thermostat (Normally Closed): Typically used to connect heaters and open the circuit when the temperature reaches the set value.

KTS 011:

Thermostat (Normally Open): Typically used to monitor filter fans or heat exchangers, and close the circuit when the temperature exceeds the set value.

- Compact and space-saving design
- Long electrical service life
- Easy installation on 35mm DIN rail
- High switching performance
- Easy wiring and simple setup



KTO 011

KTS 011



SPECIFICATION

Model	KTO 011	KTS 011
Contact	NC	NO
Temperature	0°C~60°C	
Switching temperature difference	7k (± 4k tolerance)	
Sensing element	Bimetallic temperature sensing material	
Service life	>100000 cycles	
Maximum switching load	250VAC, 10A, 120VAC, 15A, DC15A	
Connection method	Screw Terminal	
Shell	UL94 V-0	
Install	Installation of 35mm DIN rail	
Size	64x33x44mm	
Weight	40g	

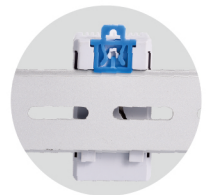

Connection Example

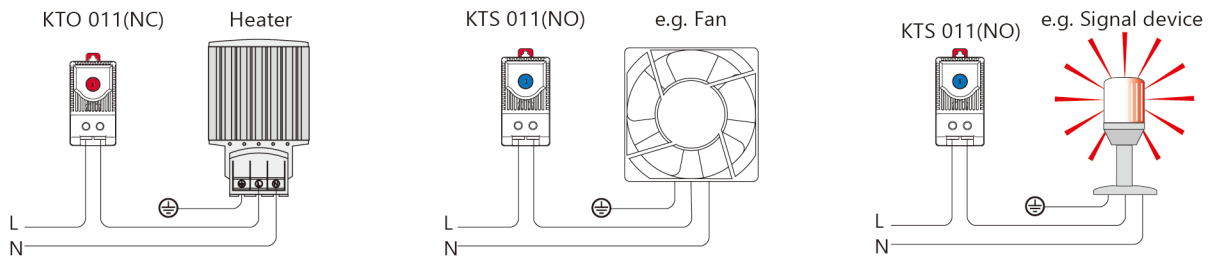

DIMENSION (mm)

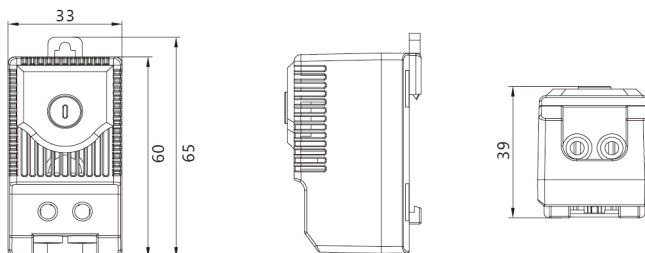

WIRING DIAGRAM

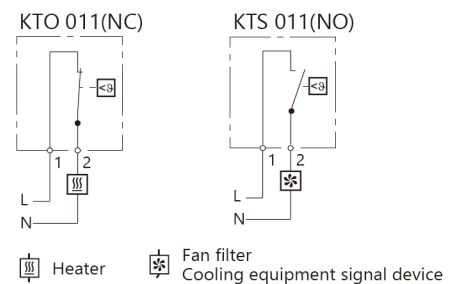

A Temperature Controller with Dual Temperature Settings

Normally Open (NO) Contact: Typically used to monitor filter fans or heat exchangers, and closes the circuit when the temperature exceeds the set value.

Normally Closed (NC) Contact: Typically used to connect heaters and opens the circuit when the temperature reaches the set value.

This design allows independent switching of heating and cooling equipment, preventing temperature deviations common with traditional switching methods.

- Wide temperature setting range
- Easy installation on 35mm DIN rail
- Integrated NO and NC contacts
- High switching performance
- Bimetallic temperature sensing element
- Independent temperature settings



SPECIFICATION

Model	ZR 011
Contact	NC+NO
Temperature	0°C~60°C
Switching temperature difference	7k (± 4k tolerance)
Sensing element	Bimetallic temperature sensing material
Service life	>100000 cycles
Maximum switching load	250VAC, 10A, 120VAC, 15A, DC15A
Connection method	Screw Terminal
Shell	UL94 V-0
Install	Installation of 35mm DIN rail
Size	67x50x46mm
Weight	88g



DIMENSION (mm)

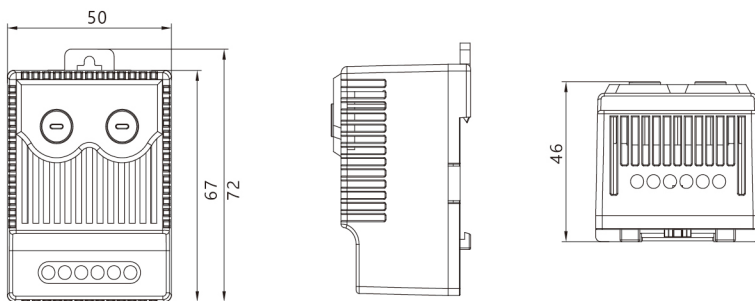

WIRING DIAGRAM

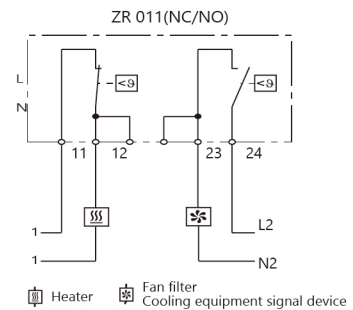

Heater
 Fan filter
 Cooling equipment signal device

KNE 110

HYGROTHERMOSTAT

Features:

- Four selectable operating modes with configurable ambient temperature and humidity thresholds
- Utilizes a capacitive humidity sensor for low power consumption and stable performance
- Passive relay output for driving cooling fans, TEC, heating wires, and other devices
- LED indicator displays the operational status of the relay
- Wide-range AC power supply: 85~240V
- Ultra-compact design with only 18mm width for easy 35mm DIN rail installation
- Designed for temperature and humidity control in power distribution cabinets



SPECIFICATION

Model	KNE 110
Dimensions	90x18x50mm
Voltage	AC 100-240V 50/60Hz
Power	1W
Weight	65g
Power terminal	A1-A2
Temperature range	10°C~60°C
Humidity range	50%~90%RH
Working temperature	-20°C~+80°C
Installation mode	35mm DIN rail
Connection	1*2.5mm ² / 2*1.5mm ² 0.4N·m

IP20

CE

-20 +80
°C

DIMENSION (mm)

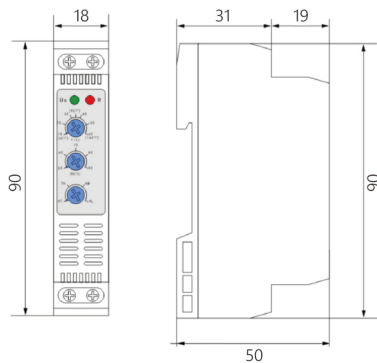

WIRING DIAGRAM

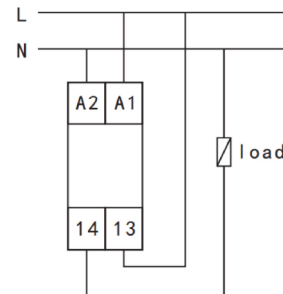

PANEL DIAGRAM

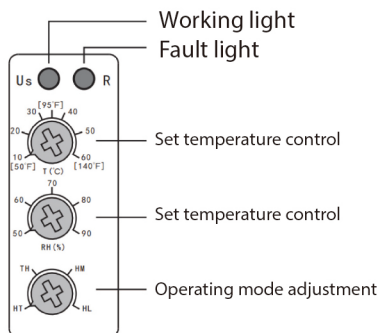

Control Heater:

When the internal cabinet temperature falls below the minimum set value, the circuit closes to begin heating. The circuit opens when the temperature exceeds the set value.

Control Fan Filter:

When the internal cabinet temperature rises above the maximum set value, the circuit closes to activate cooling. The circuit opens when the temperature drops below the set value.

- Compact and space-saving design
- Long electrical service life
- Easy installation on 35mm DIN rail
- Snap-action metal temperature sensing contact
- Convenient wiring and simple setup
- Wide temperature setting range

Technical Specifications

Alarm Output Contact: Passive contact, rated for AC 250V 5A

Alarm Logic (NC - Normally Closed): Contact closes upon dehumidification function failure

Dehumidification function failure is defined as:

Temperature or humidity sensor malfunction, OR

The relative humidity remains $\geq 80\%$ after the dehumidifier has operated continuously for 24 hours



KNC 011

KNO 011



IP20

CE

-30 +70
°C

SPECIFICATION

Model	KNC011	KNO 011
Contact	NC	NO
Temperature	0°C~60°C	
Switching temperature difference	7k (± 4k tolerance)	
Sensing element	Bimetallic temperature sensing material	
Service life	>100000 cycles	
Maximum switching load	250VAC, 10A, 120VAC, 15A, DC15A	
Connection method	Screw Terminal	
Shell	UL94 V-0	
Install	Installation of 35mm DIN rail	
Size	84x17.5x47.8mm	
Weight	40 g	



DIMENSION (mm)

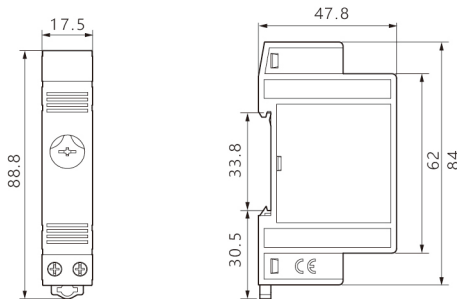

HEATING CONTROL

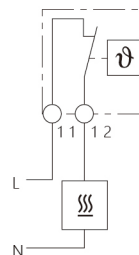

VENTILATION CONTROL

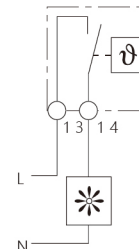

Panel Thermo-Hygrostat

- Compact design
- Electronic control system
- LED status indicator for contact operation
- Mounts on standard 35 mm DIN rail (EN 60715)



SPECIFICATION

Model	KNMF012
Contact	NO
Rated current/Maximum peak current	10/15A
Rated voltage/Maximum switching voltage	250/400V AC
Service life	>100000 cycles
Size	89x17.5x48mm
Temperature specifications	
Setting range (ventilation)	-20°C~ 80°C
Switch differential	4 ± 2K
Setting accuracy full range	-1...+3K
Humidity specifications	
Setting range (humidity)	50...90%
Hysteresis	4 ± 2%
Setting accuracy	5%

DIMENSION (mm)

WIRING DIAGRAM

Screw terminal

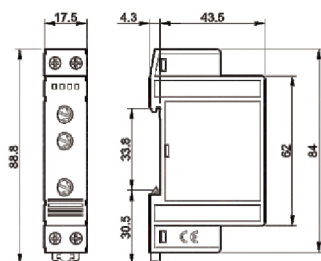

P7T.51

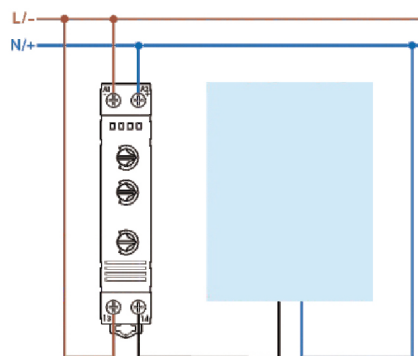

This temperature regulator is ideal for controlling filter fans, heaters, and heat exchangers. It can also serve as a signal generator for monitoring the internal temperature of control cabinets.

- Compact and space-saving design
- Convenient wiring via terminal blocks
- Dynamic heating with high-temperature limitation
- Easy installation on 35mm DIN rail
- Wide operating voltage range
- Long service life

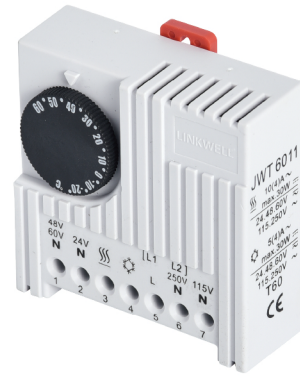

Performance & Specifications

Sensing Element: Bi-metal controller with thermal feedback
Contact Configuration: Single-pole change-over, quick-break contact
Voltage Range: Compatible with a wide range from 24V~230V AC/DC
Connection: Time-saving terminal blocks accessible from the front
Mounting: Can be mounted vertically or horizontally on a 35mm DIN rail per EN 60715; can also be clipped onto TS/35 cabinet profiles using an accessory adapter



SPECIFICATION

Temperature measurement range	-20°C~80°C	
Rated working voltage	230/115/60/48/24V (AC) 60/48/24V (DC)	
Temperature sensing element	Bimetallic temperature sensing material	
Size	71x71x33.5mm	
Weight	About 105g	
Switch difference	Approximately 1K ± 0.8K	
Permissible contact load	KI.5-3 (heating)	KI.5-4 (cooling)
(1)=inductive load	Communication 10 (4) 1 A	Communication 5 (4) 1 A
At cos φ= at 0.6 hours	DC=30W	DC=30W



TERMINAL NUMBER

		(1) L	(L2*)250V N
3	4	5	6

DIMENSION (mm)

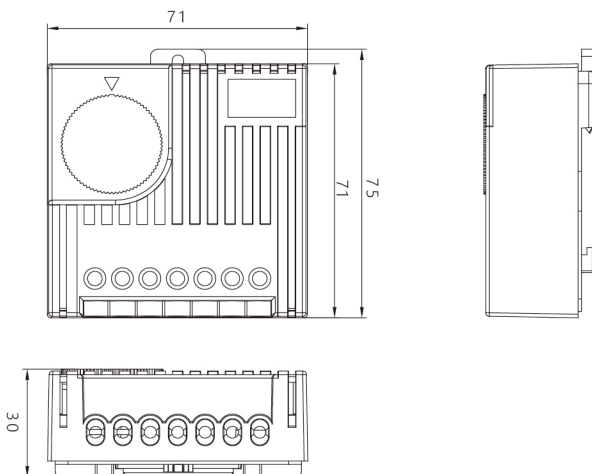

WIRING DIAGRAM

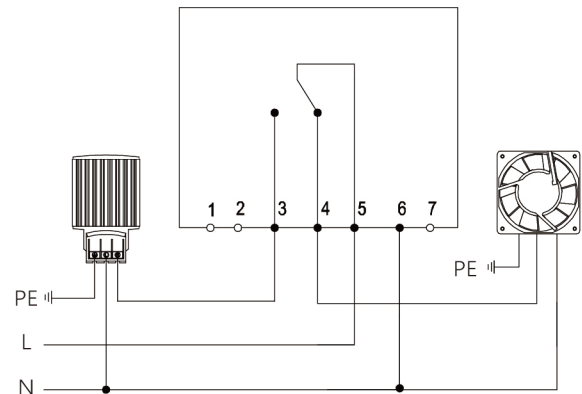

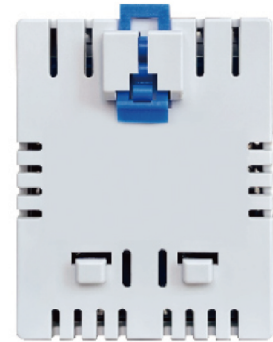

SPECIFICATION

Model	THR011
Contact	NC+NO
Voltage	230VAC
Temperature	-20°C~80°C
Switching temperature difference	7k (± 4k tolerance)
Sensing element	Electronic components
Service life	>100000 cycles
Maximum switching load	250VAC, 5A
Connection method	Screw Terminal
Shell	UL94 V-0
Install	Installation of 35mm DIN rail
Size	72X58X32mm
Weight	65g



DIMENSION (mm)

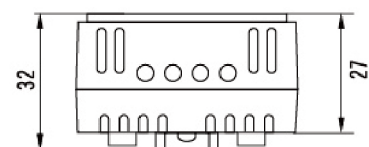
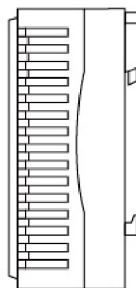
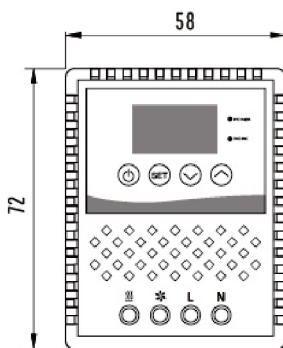

Operation & Control:

The operating range of the humidifier is set via the range knob. The humidity sensor continuously monitors the environment. When the actual humidity falls below the set value, output power is supplied to the load. When the actual humidity rises above the set value, the output power is cut off.

To prevent the load from frequently cycling on and off at the set point, this product incorporates a hysteresis of 5% ~ 10%. This means the device will only reactivate after the humidity has dropped 5~10% below the set point.

Load Selection: The product can be configured to drive loads of different sizes and types based on customer requirements.

- 35% ~ 95% adjustable relative humidity range
- Long service life
- Easy installation on a 35mm DIN rail
- Single-pole, double-throw (SPDT) contact
- High switching performance



SPECIFICATION

Switching error	4% relative humidity (± 3% tolerance)
Relative humidity range	35%~95%
Allowable wind speed	15m/sec
Contactor type	Conversion contact
Contactor resistance	< 10m Ω
Service life	> 50000 cycles
Minimum switching capacity	20V AC/DC 100mA
Maximum switching load	250V AC, 5 (1) A, DC 20W
Connection method	3-pole wiring terminal, maximum clamping torque 0.5Nm: 2.5mm ² for steel wire 1.5mm ² for multi-stranded glued wire (end)
Shell	UL94V-0 plastic, light gray
Install	Installation of 35mm DIN rail
Size	67x50x38mm
Weight	60g
Protection level	IP20

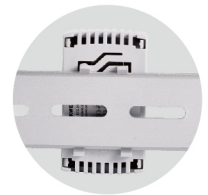

Model	Set Range
MFR012	35~95% RH

CONNECTION EXAMPLE

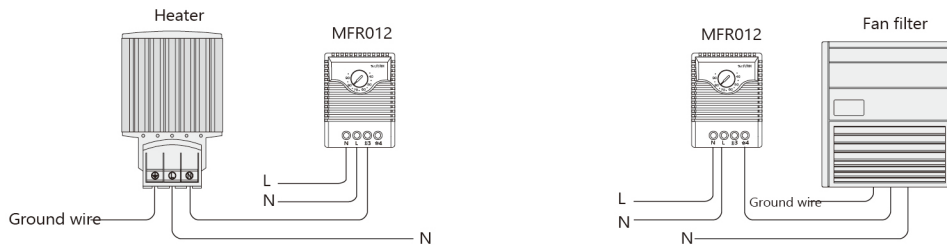

DIMENSION (mm)

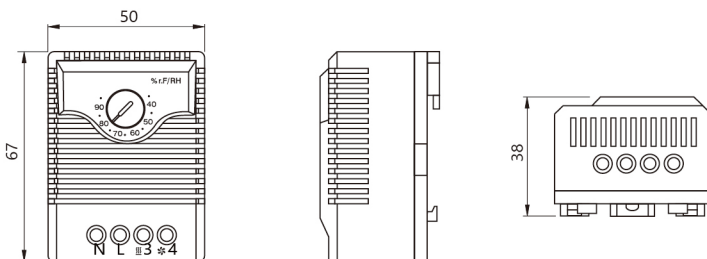

WIRING DIAGRAM

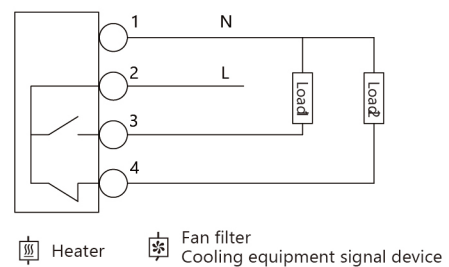

MFR012-2 (Mechanical)

HYGROSTAT

The MFR012-2 humidistat is designed to control a heater within a switch box. When humidity exceeds the set level, the heater activates to expel moist air. This method effectively prevents condensation and rust.

- Adjustable Humidity Control
- Changeover contact (SPDT)
- High switching capacity
- Easy access for setup and wiring
- DIN rail mounting clamp
- Long electrical service life



SPECIFICATION

Switching error	4% relative humidity ($\pm 3\%$ tolerance)
Relative humidity range	35%~95%
Allowable wind speed	15m/sec
Contact type	Conversion contact
Contact resistance	$< 10\text{m}\Omega$
Service life	> 50000 cycles
Minimum switching capacity	20V AC/DC 100mA
Maximum switching load	250V AC, 5 (1) A, DC 20W
Connection method	Screw terminal
Shell	UL94 V-0 plastic, light gray
Install	Installation of 35mm DIN rail
Size	67x50x38mm
Weight	60g
Operating/storage temperature	0°C~60°C (32°F~140°F) / -20°C~80°C (-4°F~176°F)
Protection level	IP20

Model	Set Range
MFR012-2	35~95% RH



CONNECTION EXAMPLE

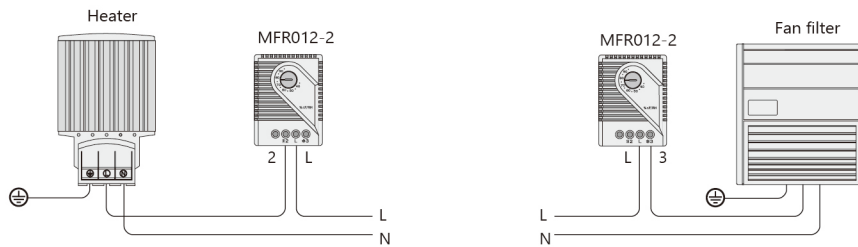

DIMENSION (mm)

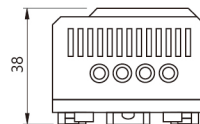
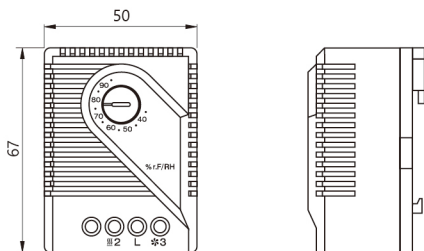

WIRING DIAGRAM

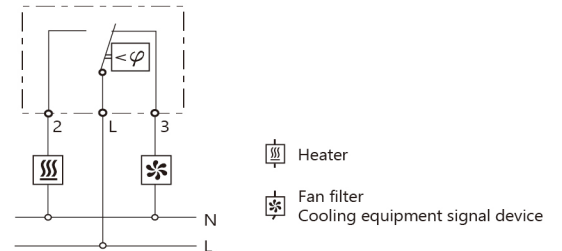

This electronic humidity controller monitors the relative humidity inside an electrical enclosure. It activates a heater once the humidity reaches the set point to prevent condensation. An LED indicator on the adjustment knob illuminates when the heater is operating.

- Adjustable and pre-set relative humidity
- Optional LED operational indicator
- High switching performance
- Easy installation on 35mm DIN rail
- Built-in temperature compensation
- Long service life



SPECIFICATION

Switch differences	5% relative humidity ($\pm 1\%$ tolerance) at 25°C / 77°F (50% relative humidity)
Reaction time	About 5 seconds
Contact method	Switching contact (relay)
Service life	>50000 cycles
Maximum switching capacity (relay output)	240VAC, 8 (1.6) A: 120V AC, 8 (1.6) A: 24V DC, 4A
Electromagnetic compatibility	Complies with EU standards EN 55014-1-2, EN 61000-3-2, EN 61000-3-3
Optical indicator	LED
Connection method	Screw terminal
Install	35mm DIN rail clamp (EN50022)
Shell	UL94 V-0 light gray plastic
Weight	About 70g
Fixed position	Vertical installation
Applicable temperature	0°C ~ 60°C (32°F ~ 140°F) / -20°C ~ 80°C (-4°F ~ 158°F)
Protection level	IP20

Model	Working voltage	Setting Range
01245.0-00	230v ac, 50/60hz	40 ~ 90% RH
01246.9-00	120v ac, 50/60hz	40 ~ 90% RH



CONNECTION EXAMPLE

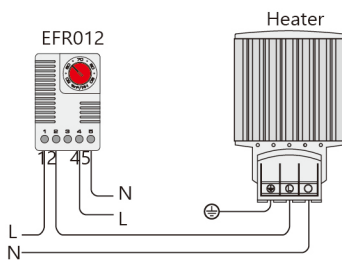

WIRING DIAGRAM

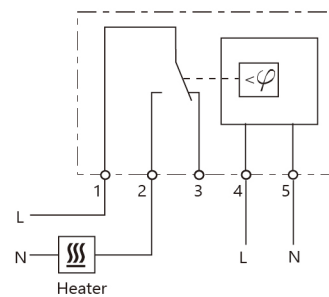

DIMENSION (mm)

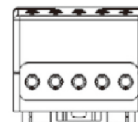
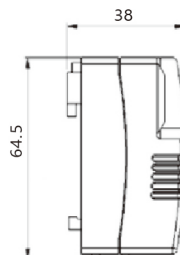
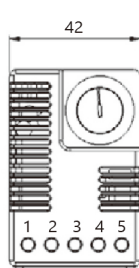

This controller is used to manage heating and cooling equipment, filter fans, or signal devices. During operation, the LED indicator will illuminate (e.g., heater on).

- Adjustable and pre-set relative humidity
- Optional LED operational indicator
- High switching performance
- 35mm DIN rail mounting
- Built-in temperature compensation
- Long service life



SPECIFICATION

Switch differences	5% relative humidity ($\pm 1\%$ tolerance) at 25°C / 77°F (50% relative humidity)
Sensor element	NTC
Reaction time	5 seconds
Contact method	Conversion contact (relay)
Service life	>50000 cycles
Maximum switching capacity (relay output)	240V AC, 8 (1.6) A 120V AC, 8 (1.6) A 100W DC at 24V DC
Maximum inrush current	16A AC in 10 seconds
Optical indicator	LED
Connection method	Screw terminal
Install	35mm DIN rail clamp, compliant with EU EN60715 standard
Shell	Light gray plastic, symbol UL94 V-0 standard
Size	64.5x42x38mm
Weight	About 70g
Installation position	Vertical
Operating/Storage Temperature	-20°C~80°C (-40°F~185°F)
Operating/Storage Humidity	Maximum humidity 90% (non condensing)

IP20

CE

-20 +80 °C



Model	Working voltage	Setting Range
01131.0-00	230V AC, 50/60Hz	-20°C~60°C

CONNECTION EXAMPLE

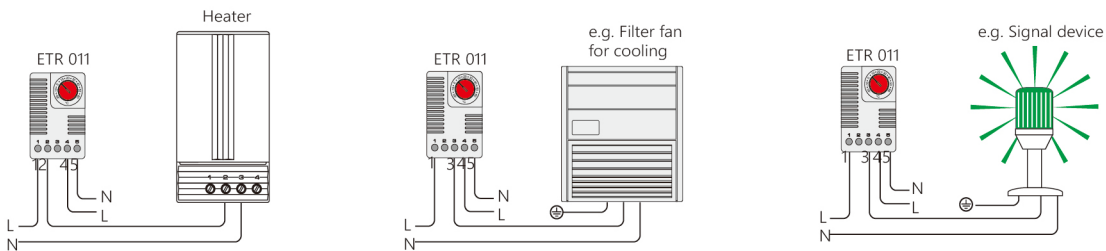

DIMENSION (mm)

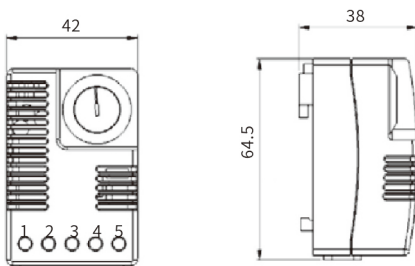

WIRING DIAGRAM

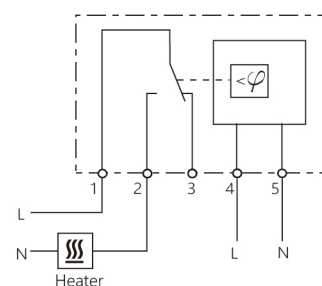

KTOMF012 Humidity & Temperature Controller (for Heating)

KTSMF012 Humidity & Temperature Controller (for Refrigeration)

Overview

An integrated controller for precise management of both temperature and humidity. Designed for long-term, stable operation in a wide range of applications.

Features

- Integrated temperature and humidity control in a single unit
- Stable and reliable long-term operation
- Visual work indicator light
- Easy installation on 35mm DIN rail
- Compact size for versatile applications
- Compliant with RoHS standards

Performance & Specifications

- Temperature Control: Automatically cuts power upon reaching the set point. Hysteresis: $\pm 1 \sim 3^{\circ}\text{C}$
- Humidity Control: Automatically cuts power upon reaching the set point. Hysteresis: 5~10% RH
- Power Supply: AC 220V (other voltages available upon request)
- Power Consumption: Approx. 46 mA (Max.)
- Operating Range: Temperature: -10 to 50°C ; Humidity: 40~90% RH
- Storage Conditions: Temperature: -20 to 60°C ; Humidity: 20~95% RH
- Sensing Element: Bimetal thermostat



KTOMF012

KTSMF012



SPECIFICATION

Switching temperature error	7k(±4k)
Switching humidity error	4% relative humidity, ±3% error
Temperature control sensor	Bimetallic temperature sensitive material
Relative humidity range	35% ~ 95%.
Temperature controlled contact form	Jump contact point
Humidity contact form	Transfer contact
Service life	750,000 cycles
Minimum switching capacity	110VAC/DC 100m A
Maximum switching capacity	240VAC 5(1)A DC 30W
Electrical connection	Screw terminal
Install	35mm DN guide rail installation
Shell	Flame retardant UL94 V-0 plastic, light gray RAL7035
Dimension	70 x 63 x 40mm
Weight	90g
Fixed position	Above cabinet
Operating temperature	0°C~60°C(32°F~140°F)
Storage temperature	-20°C~80°C(-4°F~176°F)
Class of protection	IP20



DIMENSION (mm)

WIRING DIAGRAM

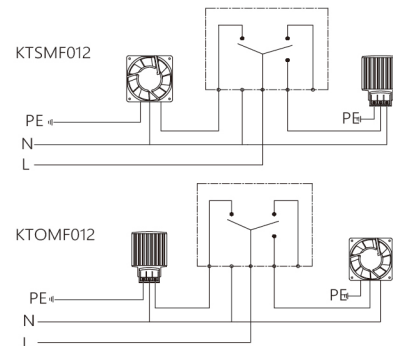
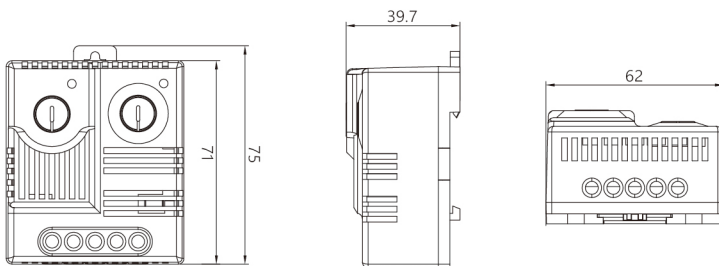

Performance:

This electronic humidity controller monitors the temperature and relative humidity inside electrical enclosures. It activates a heater (or fan) at the set point to prevent condensation. An LED indicator on the knob illuminates when the connected device is operating.

- Adjustable temperature and humidity settings
- Easy installation on 35mm DIN rail
- Visual operating status indicator (LED)
- High switching capacity
- Long service life



SPECIFICATION

Switching differences (temperature)	2K (±1% tolerance) at 25°C / 77°F (50% relative humidity)
Switching differences (humidity)	4% relative humidity (±1% tolerance) at 25°C / 77°F (50% relative humidity)
Reaction time (humidity)	About 5 seconds
Contact method	Switching contact (relay)
Contact impedance	<10m Ω
Service life	NC:>50000 cycles NO:>100000 cycles
Maximum switching capacity (relay output)	NC: 240V AC, 6 (1) A NO: 240V AC, 8 (1.6) A, NC: 120V AC, 6 (1) A NO: 120V AC, 8 (1.6) A 24V DC, 4A
Electromagnetic compatibility	Acc.to EN 55014-1-2, EN 61000-3-2, EN 61000-3-3
Optical indicator	LED
Connection method	5-pole terminal
Install	35mm DIN rail clamp (EN50022)
Shell	UL94 V-0 light gray plastic
Size	77x60x43mm
Weight	About 0.20kg
Applicable temperature	0°C~60°C(+32~140°F)/-20°C~80°C(-4°F~176°F)
Protection level	IP20



Model	Working voltage	Setting temperature	Setting Range
01230.0-00	230V AC, 50/60Hz	0°C~60°C	50 ~ 90% RH
01230.9-01	120V AC, 50/60Hz	0°C~60°C	50 ~ 90% RH

CONNECTION EXAMPLE

WIRING DIAGRAM

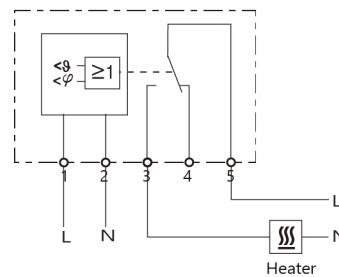
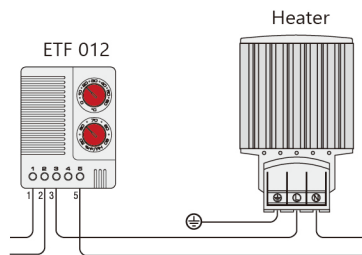

DIMENSION (mm)

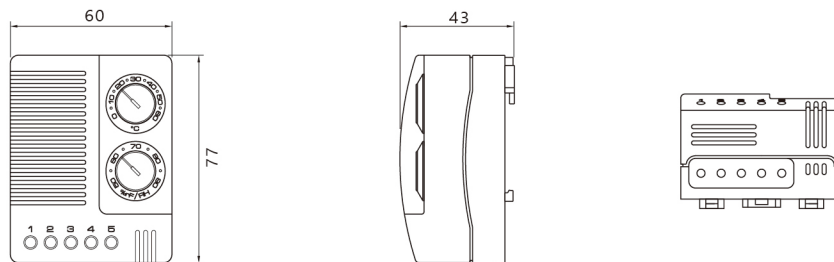



External sensor



Overview

This product utilizes an MCU (Microcontroller Unit) control system to perform real-time temperature and humidity monitoring and control, ensuring that environmental conditions remain within the appropriate range.

It features an intelligent communication function, transmitting measured temperature and humidity data via an RS-485 interface to a host computer. This allows users to remotely monitor the environmental conditions of the control cabinet in real-time.

Function Description

Temperature and humidity values are displayed on a high-definition LCD screen. The display layout is as follows (refer to Figure A):

- Measured Humidity: Displayed as a 2-digit value (e.g., 60%RH).
- Humidity Setpoint: In setting mode, the set value blinks at 500ms intervals (e.g., 40%RH).
- Measured Temperature: Displayed as a 2-digit value (e.g., 25°C).
- Temperature Setpoint: In setting mode, the set value blinks at 500ms intervals (e.g., 25°C).
- Dehumidification Mode Indicator (Figure B): A dynamic fan icon shows when the dehumidification function is active.
- Heating Mode Indicator (Figure C): A heating signal icon shows when the heating function is active.



(Figure A)



(Figure B)



(Figure C)



(Figure D)

SPECIFICATION

Supply voltage	AC220V ± 10%, other voltages can be customized
Humidity measurement range	20-90% RH (without condensation)
Humidity measurement accuracy	± 5% RH (tested at 25°C)
Temperature measurement range	5°C~60°C
Temperature measurement accuracy	± 1°C (tested at 25°C)
Humidity setting range	10-80% RH
Product Work Environment	Temperature 5°C~60°C, humidity 10~95% RH (no condensation)
Product storage environment	Temperature -10°C~40°C, humidity 10~90% RH (no condensation)
Humidification load size	Pure resistance load AC250V/10A, DC30V/5A
Power down memory	In the event of a power outage, the product's set parameters are automatically memorized.

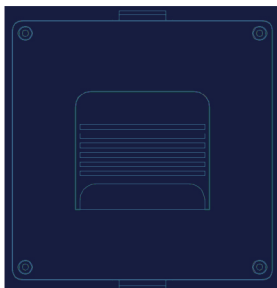

(Figure 1)

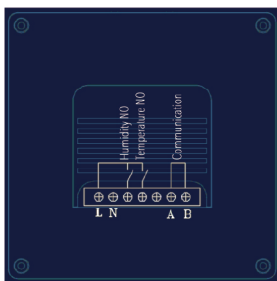

(Figure 2)

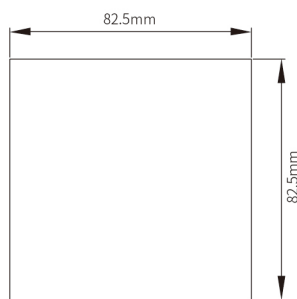

(Opening size)

1.Keys, as shown in Figure D

- "POWER" key: Press this key to switch the machine cycle.
- "SET" key: under the boot state, press the key, the product is in the humidity or temperature parameter setting State, when the humidity (or temperature) display digital tube flashes. No key pressed, 10 seconds later since move out of setting state, display the current humidity measurement value.
- "Plus" key: in the setting state, press the key, according to each press, set value plus one, wetThe maximum set value of degree is 80%, and the maximum set value of temperature is 60
- No key pressed, 10 seconds later since move to exit the setting state.
- "Minus" key: in the setting state, press the key, according to each press, set value minus one, wet the minimum set value of degree is 10%, and the minimum set value of temperature is 5
- No key pressed, 10 seconds later since move to exit the setting state.

2. Control the output

2.1 Humidity control output when the humidity measurement value is greater than the humidity set value, the output relay is closed and the dehumidification work begins when, the running indicator - fan rotation; when The humidity measurement value is less than (set value -5), stop dehumidify, and the running indicator is off. Humidity return difference is 5%rh to prevent load from opening frequently at zero cut-off point. Affect the service Life. During the initial power-on, the output delay is 3 seconds, that is, after 3 seconds, the output is wet after the Degree condition, the control dehumidification relay starts to operate and the display starts to run.

2.2 Temperature control output when the temperature measurement value is less than the humidity set value, the output relay closes and starts heating (dehumidification).work, at this time, the running indicator -- heating wire display; when the temperature measurement is greater than (set value+2), stop heating, and the running Indicator is off. The temperature return difference is 2 to prevent the load at zero boundary points open frequently, Affecting the service life. During the initial power-on, the output delay is 3 seconds, that is, 3 seconds later, When the humidity condition is satisfied, the control heating relay starts to operate and the display starts to run.

2.3 Power failure memory to ensure that user parameter settings remain unchanged after power failure, memory protection power is added. 2.4 communication part this product adopts 485 communication mode, temperature, humidity and running status parameters are uploaded to the remote calculation on board.

3. Overall dimensions and wiring drawings, as shown in Figure 1.

KTH082 remote intelligent monitor for temperature and humidity www.cnlinkwell.com

3.1 The installation mode of this product is embedded, and the opening size is 82.5*82.5 (unit: mm).

3.2 Schematic diagram of wiring terminals on the back of controller, as shown in Figure 2

- (1) AC220V/50Hz: Connect terminals L and N;
- (2) Load terminal: normally open point heater, normally closed point fan;
- (3) 485 communication terminal: Connect A and B.