



LINKWELL
ELECTRIC



TERMINAL BLOCKS SERIES



LINKWELL
ELECTRIC

LK SERIES DISTRIBUTION TERMINAL BLOCK

- Visual inspection of wire: confirmation of connection
- Space saving: compact
- Tinned copper block: high conductivity
- IP 20 protection/UL finger-safe: improved safety
- Cable fixing screw diameters >95% fill ratio: excellent electrical contact, safe connections
- Hinged or removable cover: easy wiring
- Clip-on DIN rail or mount to panel with screws: easy fixing



LK-80A

80A IEC 60947-7-1
85 Amp



IP20

UL US

CE

RoHS COMPLIANT

UL94-V0

Modular:

Keeping only one input, the blocks can be connected in parallel using a jumper wire. Easily double or triple the neutral.

■ Dimensions

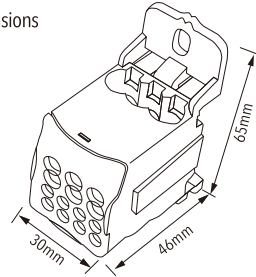

I=80A IEC
I=85A UL/CSA
□ Icw KA rms Is:3
□ IPK KA:22
□ Ui:1000V IEC
600V UL

■ Metric **or common jumper

Unit	mm ²			Γ(N.m)
	6...16	X1		3.5
	2.5...6	X4		1.2
	2.5...16	X2		3.5

■ Imperial

Unit	AWG			Torque Inch/Lbs.
	16...4	X1		19.5
	16...8	X4		10.6
	16...4	X2		19.5

Modular:

Keeping only one input, the blocks can be connected in parallel using a jumper wire. Easily double or triple the neutral.

■ Dimensions

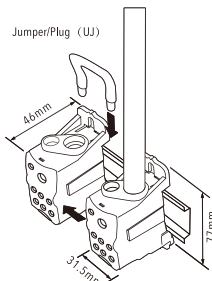

I=125A IEC
I=150A UL/CSA
□ Icw KA rms Is:4.2
□ IPK KA:30
□ Ui: 1000V IEC
600V UL

■ Metric **or common jumper

Unit	mm ²			Γ(N.m)
	10...35	X1		8.5
	6...16**	X1		3.5
	2.5...16	X6		3.5

■ Imperial

Unit	AWG			Torque Inch/Lbs.
	8...1/0	X1		57
	14...2	X1		31
	14...4	X6		31

■ Accessories UJ



LK-125A

125A IEC 60947-7-1
150 Amp



IP20

UL US

CE

RoHS COMPLIANT

UL94-V0

LK-160A

160A IEC 60947-7-1
200 Amp



Modular:

Keeping only one input, the blocks can be connected in parallel using a jumper wire. Easily double or triple the neutral.

■ Dimensions

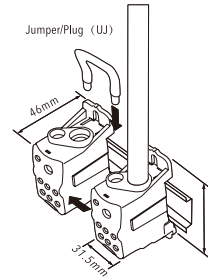

I=160A IEC
I=200A UL/CSA
□ Icw KA rms Is:11.8
□ IPK KA:30
□ Ui:1000V IEC
600V UL

■ Metric ** or common jumper

Unit	mm ²			I(N.m)
	10...70	X1		8.5
	6...16**	X1		3.5
	2,5...16	X6		3.5

■ Imperial

Unit	AWG			Torque Inch/Lbs.
	8...3/0	X1		75
	14...2	X1		31
	14...4	X6		31

■ Accessories UJ



Modular:

Allows versatile building of power blocks single pole, two pole, three pole or four pole.

■ Dimensions

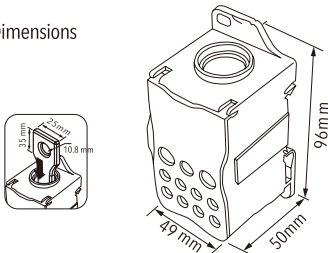

I=250A IEC
I=255A UL/CSA
□ Icw KA rms Is:24.5
□ IPK KA:51
□ Ui:1000V IEC
600V UL

■ Metric ** or common jumper

Unit	mm ²	mm ²			I(N.m)
	35...120		X1		19
	6...35	6...25	X2		4.4
	2.5...16	2.5...16	X5		2.7
	2.5...10	2.5...10	X4		2.7

■ Imperial

Unit	AWG			Torque Inch/Lbs.
	6...250 Kcmil	X1		221
	14...1	X2		39
	14...4	X5		24
	14...6	X4		24

■ Accessories TF 250A



LK-250A

250A IEC 60947-7-1
255 Amp



LK-400A

400A IEC 60947-7-1
355 Amp



IP20

CE

UL

RoHS COMPLIANT

UL94-V0

Modular:

Allows versatile building of power blocks single pole, two pole, three pole or four pole.

■ Dimensions

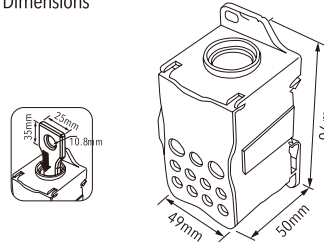

I=400 A IEC
I=355 A UL/CSA
□ Icw KA rms Is:24.5
□ IPK KA:51
□ Ui:1000V IEC
600V UL

■ Metric **or common jumper

Unit	mm ²	mm ²			Γ(N.m)
	95...185		X1		25
	6...35	6...25	X2		4.4
	2.5...16	2.5...16	X5		2.7
	2.5...10	2.5...10	X4		2.7

■ Imperial

Unit	AWG				Torque Inch/Lbs.
	3/0...400 Kcmil	X1			221
	14...1	X2			39
	14...4	X5			24
	14...6	X4			24

■ Accessories TF 400A



Modular:

Allows versatile building of power blocks single pole, two pole, three pole or four pole.

■ Dimensions

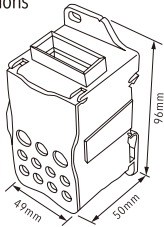

I=500 A IEC
I=520 A UL/CSA
□ Icw KA rms Is:24.5
□ IPK KA:51
□ Ui:1000V IEC
600 V UL

TH flexible busbar

	4 x 15.5 x 0.8
	6 x 15.5 x 0.8
	2 x 20 x 1
	3 x 20 x 1
	4 x 20 x 1
	5 x 20 x 1
	6 x 20 x 1
	2 x 24 x 1
	3 x 24 x 1
	4 x 24 x 1
	5 x 24 x 1
	6 x 24 x 1
	8 x 24 x 1

■ Metric **or common jumper

Unit	mm ²	mm ²			Γ(N.m)
	4x15,5x0.8,6x24x1	4x15,5x0.8,6x24x1			10
	6...35	6...25	X2		4.4
	2.5...16	2.5...16	X5		2.7
	2.5...10	2.5...10	X4		2.7

■ Imperial

Unit	AWG				Torque Inch/Lbs.
	4x15,5x0.8,6x24x1				88.5
	14...1	X2			39
	14...4	X5			24
	14...6	X4			24

LK-500A

500A IEC 60947-7-1
520 Amp

Connected with Flexible busbar



IP20

CE

UL

RoHS COMPLIANT

UL94-V0

LKH-125A

125A IEC 60947-7-1



Modular:

Keeping only one input, the blocks can be connected in parallel using a jumper wire. Easily double or triple the neutral.

■ Dimensions

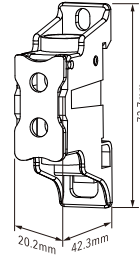

I= 125A IEC
□ Icw KA rms Is: 4.2
□ IPK KA: 25
□ Ui: 1000V IEC

■ Metric ** or common jumper

Unit	mm ²			Γ(N.m)
	10...35	X1		8.5
	10...35	X1		8.5

■ Imperial

Unit	AWG			Torque Inch/Lbs.
	8...1/0	X1		57
	8...1/0	X1		57

Modular:

Keeping only one input, the blocks can be connected in parallel using a jumper wire. Easily double or triple the neutral.

■ Dimensions

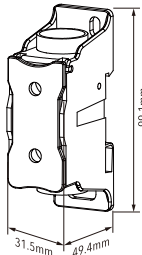

I= 255A IEC
□ Icw KA rms Is: 14.4
□ IPK KA: 42
□ Ui: 1000V IEC

■ Metric ** or common jumper

Unit	mm ²			Γ(N.m)
	35...120	X1		19
	35...120	X1		19

■ Imperial

Unit	AWG			Torque Inch/Lbs.
	6...250Kcmil	X1		168
	6...250Kcmil	X1		168

LKH-250A

255A IEC 60947-7-1



LDB-80

80A IEC 60947-7-1

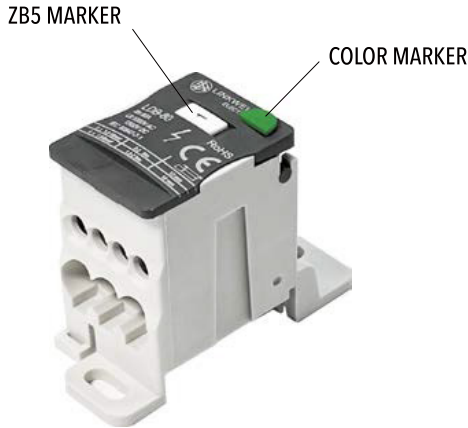

Modular:

Keeping only one input, the blocks can be connected in parallel using a jumper wire. Easily double or triple the neutral.

■ Dimensions

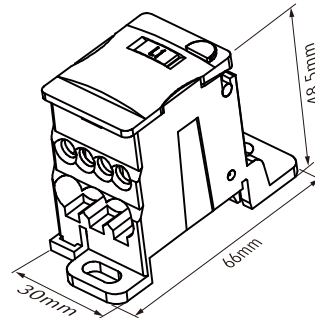

I=80A IEC
□ Icw KA rms Is:3
□ IPK KA:22
□ Ui: 1000V IEC



■ Metric **or common jumper

Unit	mm ²			I'(N.m)
	1.5...16	X1		2-3
	1.5...6	X4		1.5-2
	1.5...16	X2		2-3

Modular:

Keeping only one input, the blocks can be connected in parallel using a jumper wire. Easily double or triple the neutral.

■ Dimensions

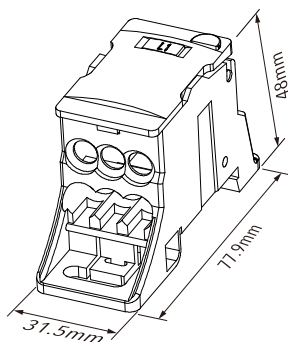

I=125A IEC
□ Icw KA rms Is:4.2
□ IPK KA:30
□ Ui: 1000V IEC

LDB-125

125A IEC 60947-7-1

■ Metric **or common jumper

Unit	mm ²			I'(N.m)
	10...35	X1		5-8
	6...16**	X1		2-3
	2.5...16	X6		2-3

■ Accessories UJ



LDB-160

160A IEC 60947-7-1



Modular:

Keeping only one input, the blocks can be connected in parallel using a jumper wire. Easily double or triple the neutral.

■ Dimensions

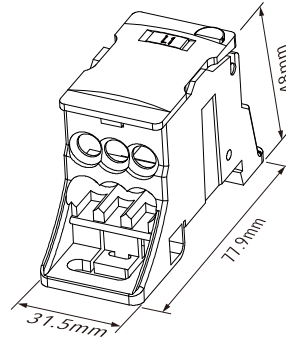

I= 160A IEC
□ I _{cw} KA rms Is: 11.8
□ IPK KA: 30
□ Ui: 1000V IEC

■ Metric ** or common jumper

Unit	mm ²			I'(N.m)
	10...70	X1		8-10
	6...16**	X1		2-3
	2,5...16	X6		2-3

■ Accessories UJ

Modular:

Keeping only one input, the blocks can be connected in parallel using a jumper wire. Easily double or triple the neutral.

■ Dimensions

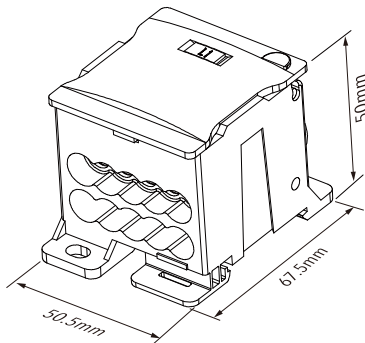

I= 200A IEC
□ I _{cw} KA rms Is: 15
□ IPK KA: 35
□ Ui: 1000V IEC

LDB-200

200A IEC 60947-7-1



■ Metric ** or common jumper

Unit	mm ²			I'(N.m)
	10...95	x2		8-10
	2.5...16	x8		2-3

LDB-250

250A IEC 60947-7-1



Modular:

Keeping only one input, the blocks can be connected in parallel using a jumper wire. Easily double or triple the neutral.

■ Dimensions

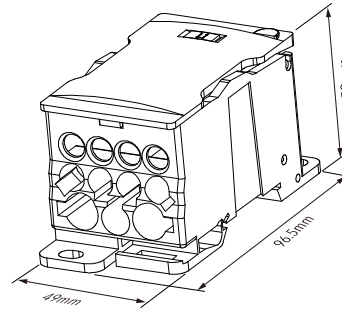

I=250A IEC
□ I _{cw} KA rms Is:24.5
□ IPK KA:51
□ Ui: 1000V IEC

■ Metric ** or common jumper

Unit	mm ²	mm ²			I(N.m)
	35...120		X1		19-21
	6...35	6...25	X2		3.5-5
	2.5...16	2.5...16	X5		2-3
	2.5...10	2.5...10	X4		2-3

■ Accessories TF 250A



Modular:

Keeping only one input, the blocks can be connected in parallel using a jumper wire. Easily double or triple the neutral.

■ Dimensions

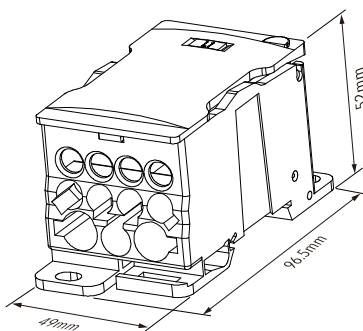

I=400 A IEC
□ I _{cw} KA rms Is:24.5
□ IPK KA:51
□ Ui: 1000V IEC

LDB-400

400A IEC 60947-7-1



■ Metric ** or common jumper

Unit	mm ²	mm ²			I(N.m)
	95...185		X1		22-25
	6...35	6...25	X2		3.5-5
	2.5...16	2.5...16	X5		2-3
	2.5...10	2.5...10	X4		2-3

■ Accessories TF 400A



LDB-500

500A IEC 60947-7-1

Connected with Flexible busbar



Modular:

Keeping only one input, the blocks can be connected in parallel using a jumper wire. Easily double or triple the neutral.

■ Dimensions

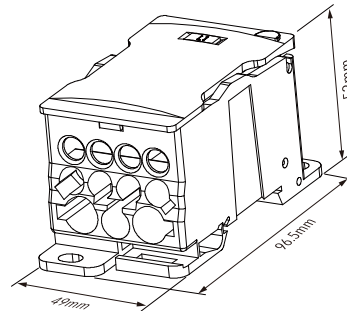

I=500 A IEC
□ Icw KA rms Is:24.5
□ IPK KA:51
□ Ui: 1000V IEC

TH flexible busbar

☞	4 x 15.5 x 0.8
☞	6 x 15.5 x 0.8
☞	2 x 20 x 1
☞	3 x 20 x 1
☞	4 x 20 x 1
☞	5 x 20 x 1
☞	6 x 20 x 1
☞	2 x 24 x 1
☞	3 x 24 x 1
☞	4 x 24 x 1
☞	5 x 24 x 1
☞	6 x 24 x 1
☞	8 x 24 x 1

■ Metric ** or common jumper

Unit	mm ²	mm ²		Γ(N.m)
☞	4x15,5x0.8,6x24x1	4x15,5x0.8,6x24x1		8-10
☞	6...35	6...25	X2	3.5-5
☞	2.5...16	2.5...16	X5	2-3
☞	2.5...10	2.5...10	X4	2-3



LINKWELL
ELECTRIC

DB SERIES COMPACT DISTRIBUTION BLOCKS

TECHNICAL FEATURES

Insulating body: PA66 UL94-V0
Cover: PC UL94-V0, transparent yellow
Conduction block: Tinned copper
Screws: Galvanized steel
Index Protection IP20
Compliant with standard EN 60947-7-1

■ RANGE

1 pole: 80 - 125 - 160 - 250 - 400 A
3 pole: 125 - 160 A

Opening and removing
front protection cover

Milled clamp for input connections by indirect
tightening:
- highly reliable connection
- flat conductors i.e. flexible and rigid bars are
allowed

Body structure
with high dielectric features

Effective tightening by means
of hexagonal screws

Direct mounting on DIN rail

Pluggable or parallel connection

Mounting on plate by screws

Guided access of cables

DB 16/6 3/4

1 Pole 80 A

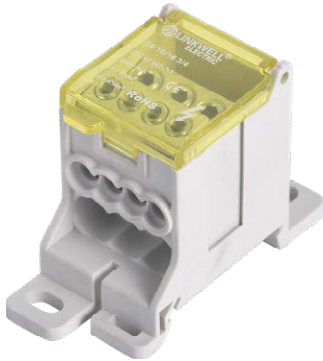

Copper or aluminum cable input

■ Dimensions

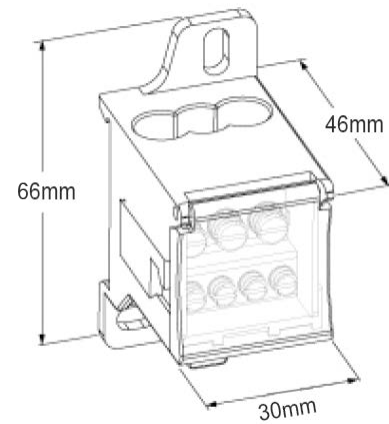

Unit	mm ²		∅		I(N.m)
	2.5...16	X1	6.2		3.0
	2.5...6	X4	4.5		1.5
	2.5...16	X2	6.2		3.0

Copper or aluminum cable input

■ Dimensions

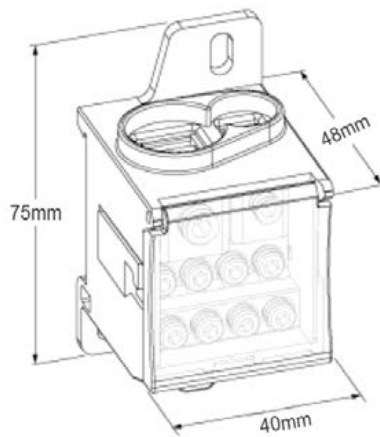

DB 35-16/16 1-1/8

1 Pole 125 A



Unit	mm ²		∅		I(N.m)
	10...35	X1			5.0
	6...16	X1	6.2		3.0
	2.5...16	X8	6.2		3.0



DB 70-16/16 1-1/8







1 Pole 160 A

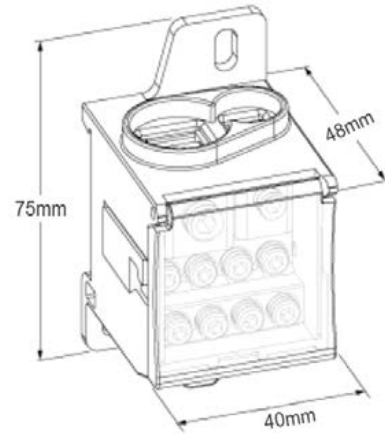

Copper or aluminum cable input

■ Dimensions



Unit	 mm ²		∅		Γ(N.m)
	16...70	X1			5.0
	6...16	X1	6.2		3.0
	2.5...16	X8	6.2		3.0

Copper or aluminum cable input



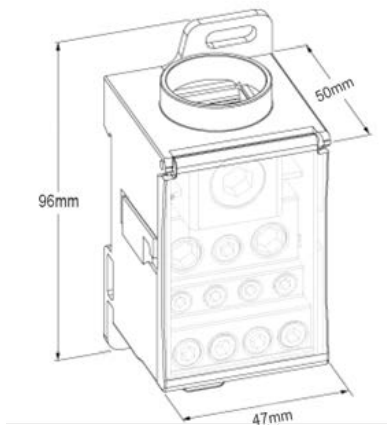





■ Dimensions



DB 120/35/16-10 1/2-5-4

1 Pole 250 A



Unit	 mm ²		∅		Γ(N.m)
	35...120	X1			19.0
	2.5...35	X2	9.5		3.5
	2.5...16	X5	6.8		6.0
	2.5...10	X4	6.2		3.0

DB 185/35-16-10 1/2-5-4

1 Pole 400 A



Copper or aluminum cable input

■ Dimensions

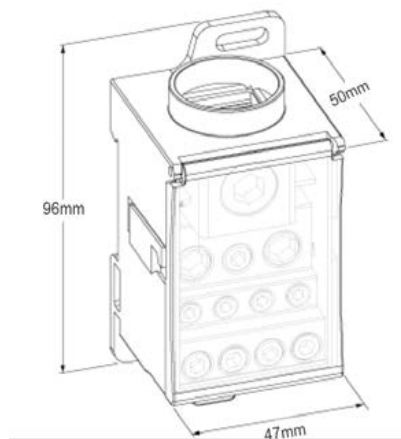

Unit	mm ²		∅		I(N.m)
	95...185	X1			25.0
	2.5...35	X2	9.5		3.5
	2.5...16	X5	6.8		2.0
	2.5...10	X4	6.2		2.0

Copper or aluminum cable input

■ Dimensions

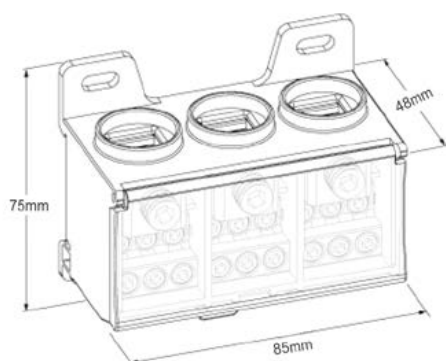

DB 3P-35/16 1/6

3 Pole 125 A

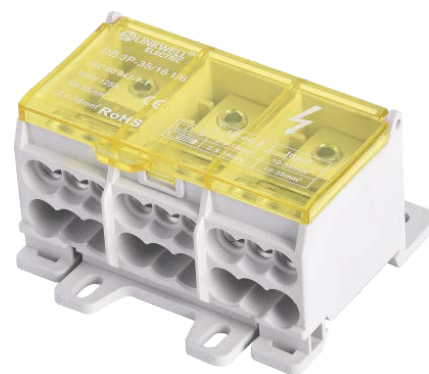

Unit	mm ²		∅		I(N.m)
	10...35	X3			5.0
	2.5...16	X18	6.2		3.0







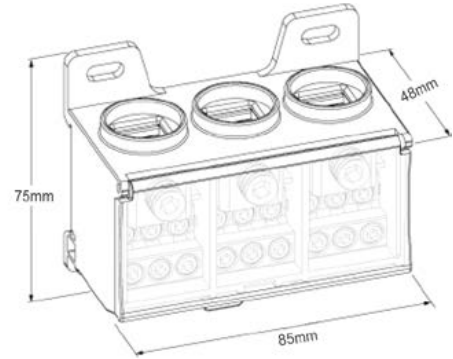

DB 3P-70/16 1/6

3 Pole 160 A

Copper or aluminum cable input

■ Dimensions



Unit	 mm ²		∅		Γ(N.m)
	16...70	X3	12		5.0
	2.5...16	X18	6.2		3.0

DB SERIES

MULTIPOLE DISTRIBUTION TERMINAL BLOCKS 125A/160A

- Minimum space for maximum power
- Easy connections : Input separated from Outputs
- Protection: Transparent cover
- Self extinguishing material : V0
- New Design: Solid brass provide more reliability
- Din rail Mounting
- Wiring with or without ferrule terminal Insulation between phases

End large terminal=
true capacity

Cover=
safe connections

One-piece forged
brass bar

Insulating screen
between each row





Easy clip-in fixing

Reinforced plastic parts

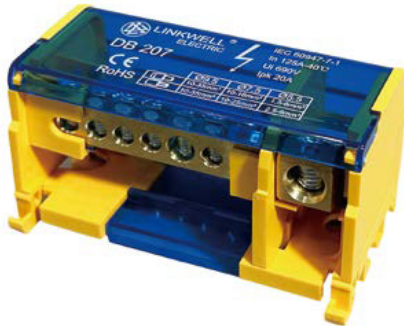
DB-207









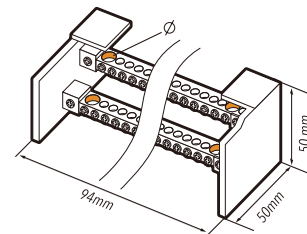

Amp = 125A Ui: 690V IEC



- For  type
- Flame retardant : UL94-V0
- Pole: 2 pole
-  Rigid cable
-  Flexible stranded cable

■ Dimensions



Unit	 mm ²	 mm ²		Ø		Γ(N.m)
	10...35	10...35	X1	9.5		3-5
	2.5...6	1.5...6	X5	5.5		2-3
	10...25	6...16	X1	7.5		2-3

Amp = 125A Ui: 690V IEC





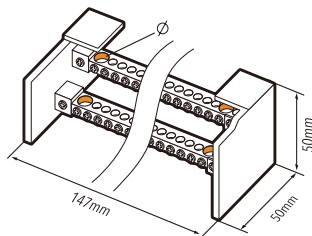

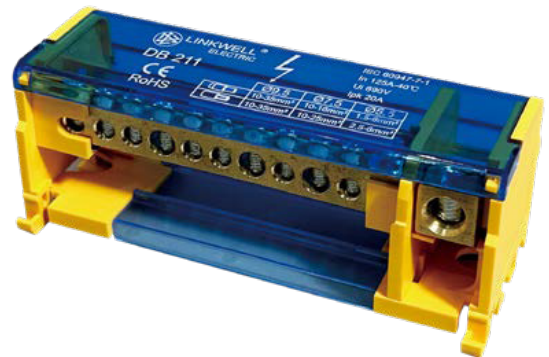

- For  type
- Flame retardant : UL94-V0
- Pole: 2 pole
-  Rigid cable
-  Flexible stranded cable

■ Dimensions



DB-211



Unit	 mm ²	 mm ²		Ø		Γ(N.m)
	10...35	10...35	X1	9.5		3-5
	2.5...6	1.5...6	X7	5.5		2-3
	10...25	6...16	X3	7.5		2-3



DB-215

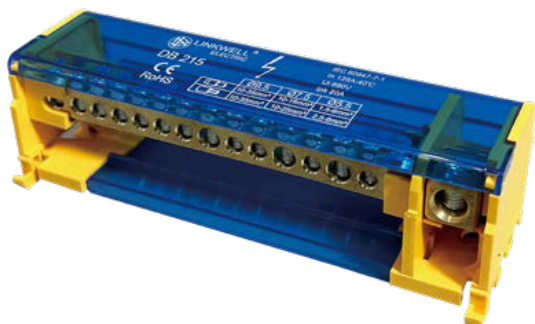

Amp = 125A Ui: 690V IEC

- For type
- Flame retardant : UL94-V0
- Pole: 2 pole
- Rigid cable
- Flexible stranded cable

■ Dimensions

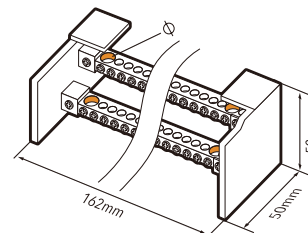

Unit	mm ²	mm ²		Ø		I(N.m)
	10...35	10...25	X1	8.5		3-5
	1.5...4	0.75...4	X11	4.5		1.2-1.5
	2.5...6	1.5...6	X3	5.5		2-3

Amp = 125A Ui: 690V IEC

- For type
- Flame retardant : UL94-V0
- Pole: 4 pole
- Rigid cable
- Flexible stranded cable

■ Dimensions

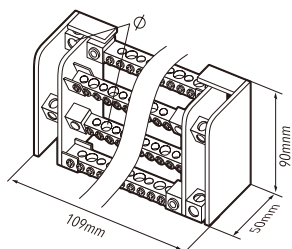

DB-407

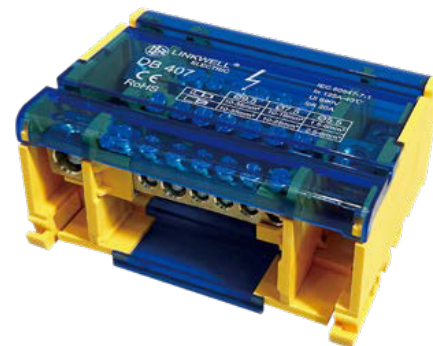



Unit	mm ²	mm ²		Ø		I(N.m)
	10...35	10...35	X1	9.5		3-5
	2.5...6	1.5...6	X5	5.5		2-3
	10...25	6...16	X1	7.5		2-3

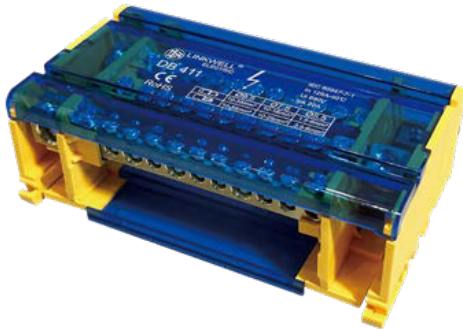

DB-411









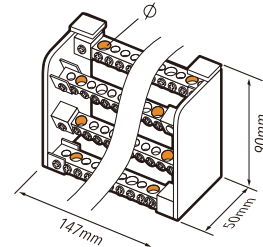

Amp = 125A Ui: 690V IEC

- For  type
- Flame retardant : UL94-V0
- Pole: 4 pole
-  Rigid cable
-  Flexible stranded cable

■ Dimensions



Unit	 mm ²	 mm ²		Ø		Γ(N.m)
	10...35	10...35	X1	9.5		6-7
	2.5...6	1.5...6	X7	5.5		2-3
	10...25	6...16	X3	7.5		2-3



IP20

CE

RoHS
COMPLIANT

UL94-V0

Amp = 160A Ui: 690V IEC





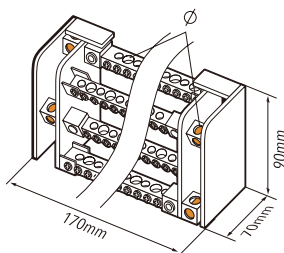

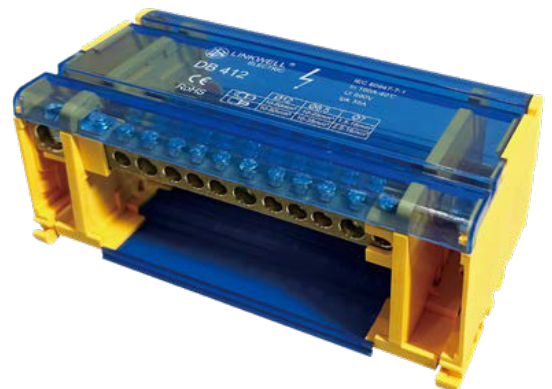

- For  type
- Flame retardant : UL94-V0
- Pole: 4 pole
-  Rigid cable
-  Flexible stranded cable

■ Dimensions



DB-412



Unit	 mm ²	 mm ²		Ø		Γ(N.m)
	10...50	10...25	X1	12		8-10
	10...35	10...25	X3	8.5		2-3
	2.5...16	1.5...16	X8	7		2-3

IP20

CE

RoHS
COMPLIANT

UL94-V0

DB-415

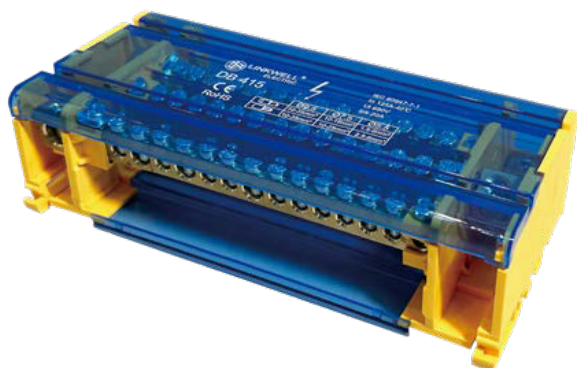

Amp = 125A Ui: 690V IEC

- For type
- Flame retardant : UL94-V0
- Pole: 4 pole
- Rigid cable
- Flexible stranded cable

■ Dimensions

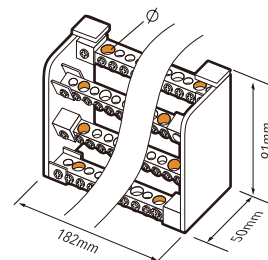



Unit	mm ²	mm ²		∅		Γ(N.m)
	10...35	10...35	X1	9.5		6-7
	2.5...6	1.5...6	X11	5.5		2-3
	10...25	6...16	X1	7.5		2-3
	10...35	10...25	X2	8.5		2-3

UK-207









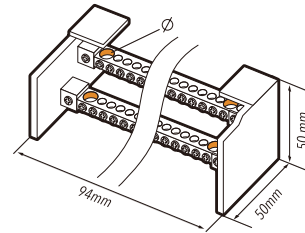

Amp = 125A Ui: 500V

- For  type
- Flame retardant : UL94-V0
- Pole: 2 pole
-  Rigid cable
-  Flexible stranded cable

■ Dimensions



Unit	 mm ²	 mm ²		Ø		Γ(N.m)
	10...35	10...35	X1	9.5		6-7
	2.5...6	1.5...6	X5	5.5		2-3
	10...25	6...16	X1	7.5		2-3



IP20

CE

RoHS
COMPLIANT

UL94-V0

Amp = 125A Ui: 500V





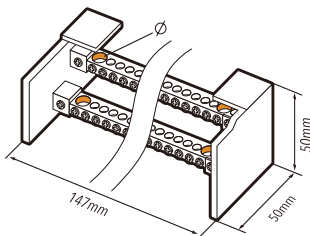

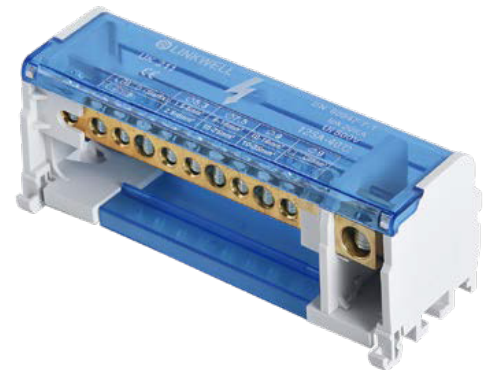

- For  type
- Flame retardant : UL94-V0
- Pole: 2 pole
-  Rigid cable
-  Flexible stranded cable

■ Dimensions



UK-211



Unit	 mm ²	 mm ²		Ø		Γ(N.m)
	10...35	10...35	X1	9.5		6-7
	2.5...6	1.5...6	X7	5.5		2-3
	10...25	6...16	X3	7.5		2-3

IP20

CE

RoHS
COMPLIANT

UL94-V0

UK-215

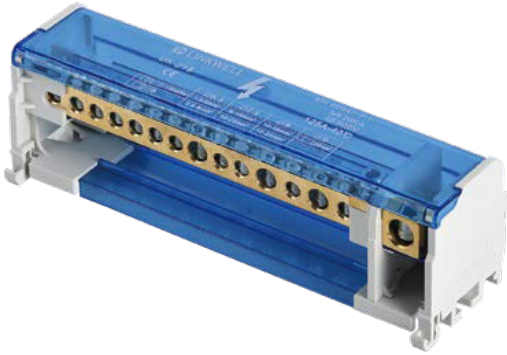

Amp = 125A Ui: 500V

- For type
- Flame retardant : UL94-V0
- Pole: 2 pole
- Rigid cable
- Flexible stranded cable

■ Dimensions

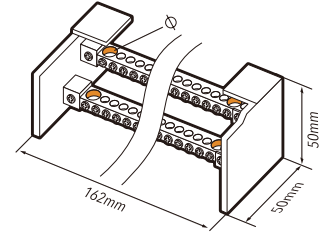

Unit	mm ²	mm ²		Ø		I(N.m)
	10...35	10...35	X1	9.5		6-7
	2.5...6	1.5...6	X11	5.5		2-3
	10...25	6...16	X3	7.5		2-3

Amp = 125A Ui: 500V

- For type
- Flame retardant : UL94-V0
- Pole: 4 pole
- Rigid cable
- Flexible stranded cable

■ Dimensions

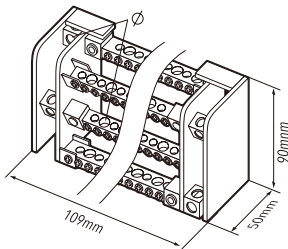

UK-407

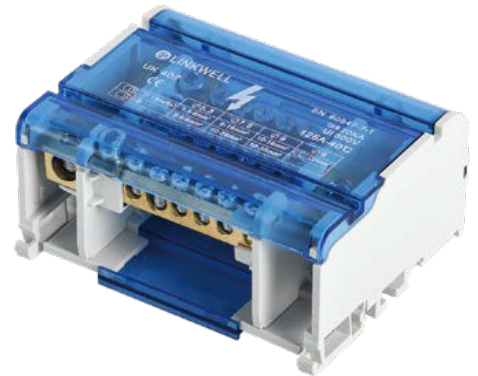



Unit	mm ²	mm ²		Ø		I(N.m)
	10...35	10...35	X1	9.5		6-7
	2.5...6	1.5...6	X5	5.5		2-3
	10...25	6...16	X1	7.5		2-3









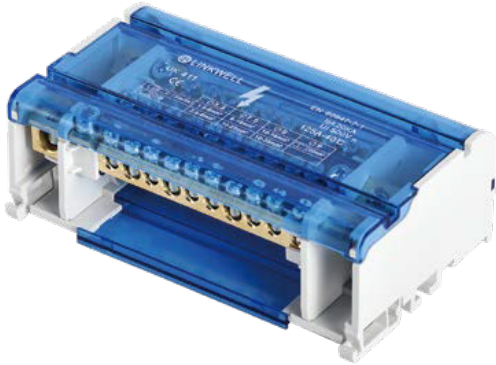
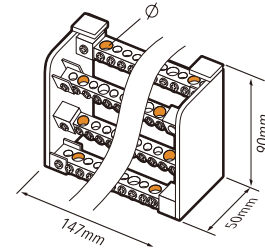

UK-411

Amp = 125A Ui: 500V



- For  type
- Flame retardant : UL94-V0
- Pole: 4 pole
-  Rigid cable
-  Flexible stranded cable

■ Dimensions



Unit	 mm ²	 mm ²		Ø		Γ(N.m)
	10...35	10...35	X1	9.5		6-7
	2.5...6	1.5...6	X7	5.5		2-3
	10...25	6...16	X3	7.5		2-3

Amp = 160A Ui: 600V





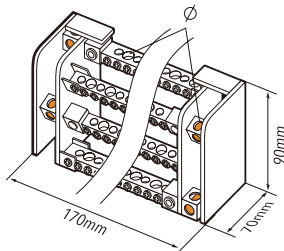

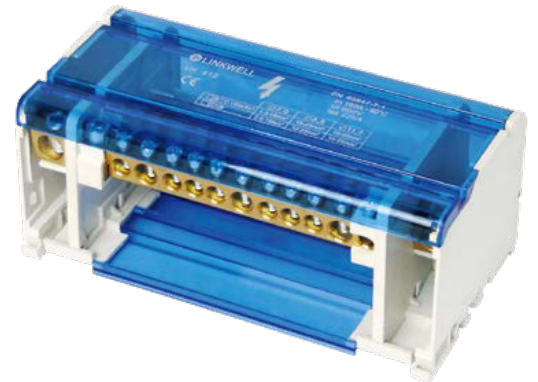

- For  type
- Flame retardant : UL94-V0
- Pole: 4 pole
-  Rigid cable
-  Flexible stranded cable

■ Dimensions



UK-412



Unit	 mm ²	 mm ²		Ø		Γ(N.m)
	10...50	10...25	X1	12		8-10
	10...35	10...25	X3	8.5		2-3
	2.5...16	1.5...16	X8	7		2-3

UK-415

Amp = 125A Ui: 500V

- For type
- Flame retardant : UL94-V0
- Pole: 4 pole
- Rigid cable
- Flexible stranded cable

■ Dimensions

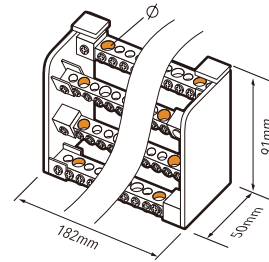
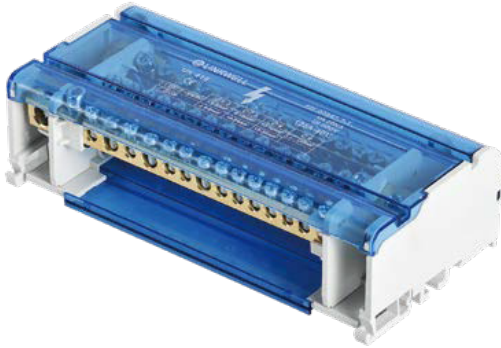

IP20

CE

RoHS COMPLIANT

UL94-V0

Unit	mm ²	mm ²		∅		Γ(N.m)
	10...35	10...35	X1	9.5		6-7
	2.5...6	1.5...6	X11	5.5		2-3
	10...25	6...16	X1	7.5		2-3
	10...35	10...25	X2	8.5		2-3

LK-207

500V

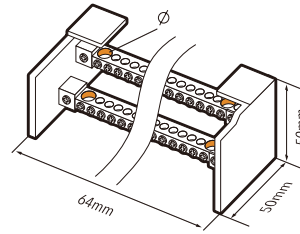
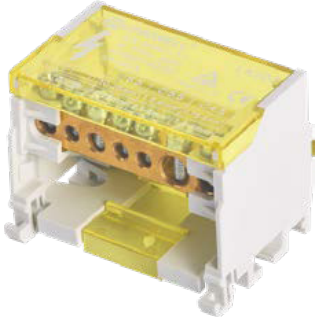

Model	LK-207	Amp=100A	LK-207B	Amp=125A
	UL94-V0		UL94-V0	
Flame retardant	2 poles	1x25mm ² /1x Ø8.5mm	2 pole	1x35mm ² /1x Ø9mm
Terminals per pole		3x6mm ² /3x Ø5.5mm		5x6mm ² /5x Ø5.5mm
		3x4mm ² /3x Ø4.5mm		1x25mm ² /1x Ø7.5mm

LK-211

500V

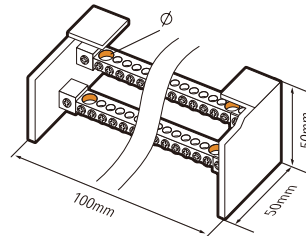
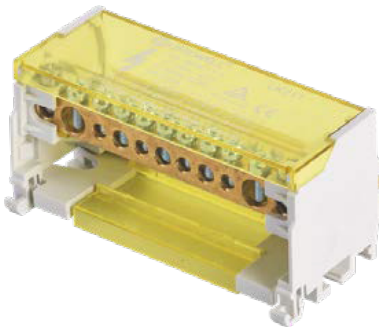

Model	LK-211	Amp=100A	LK-211B	Amp=125A
	UL94-V0		UL94-V0	
Flame retardant	2 poles	2x25mm ² /2x Ø8.5mm	2 pole	2x35mm ² /2x Ø9mm
Terminals per pole		5x6mm ² /5x Ø5.5mm		2x25mm ² /2x Ø7.5mm
		4x4mm ² /4x Ø4.5mm		7x6mm ² /7x Ø5.5mm

LK-215

500V

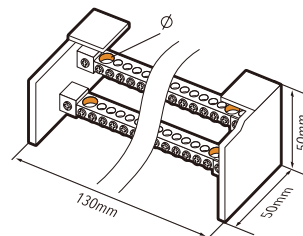
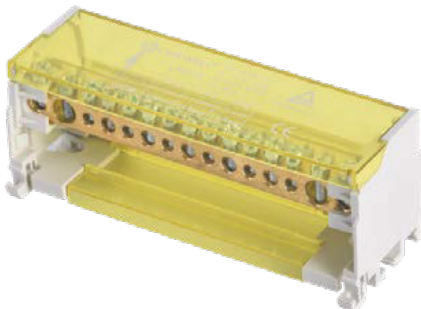

Model	LK-215	Amp=100A	LK-215B	Amp=125A
	UL94-V0		UL94-V0	
Flame retardant	2 poles	2x25mm ² /2x Ø8.5mm	2 pole	11x6mm ² /11x Ø5.5mm
Terminals per pole		7x6mm ² /7x Ø5.5mm		2x25mm ² /2x Ø7.5mm
		6x4mm ² /6x Ø4.5mm		2x35mm ² /2x Ø9mm

LK-407

500V

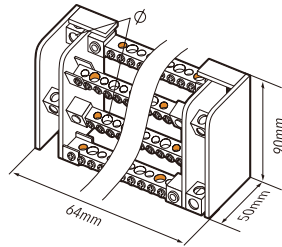

Model	LK-407	Amp=100A	LK-407B	Amp=125A
	UL94-V0		UL94-V0	
Flame retardant	4 poles	1x25mm ² /1xØ8.5mm	4 pole	1x35mm ² /1xØ9mm
Terminals per pole		3x6mm ² /3xØ5.5mm		5x6mm ² /5xØ5.5mm
		3x4mm ² /3xØ4.5mm		1x25mm ² /1xØ7.5mm



LK-411

500V

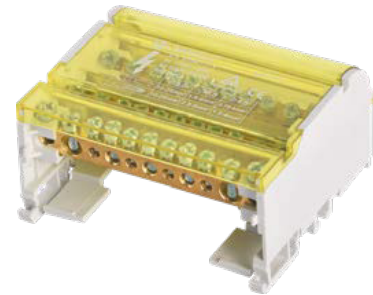
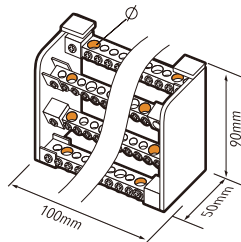

Model	LK-411	Amp=100A	LK-411B	Amp=125A
	UL94-V0		UL94-V0	
Flame retardant	4 poles	2x25mm ² /2xØ8.5mm	4 pole	2x35mm ² /2xØ9mm
Terminals per pole		5x6mm ² /5xØ5.5mm		2x25mm ² /2xØ7.5mm
		4x4mm ² /4xØ4.5mm		7x6mm ² /7xØ5.5mm



LK-415

500V

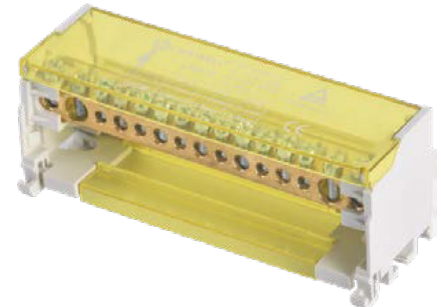
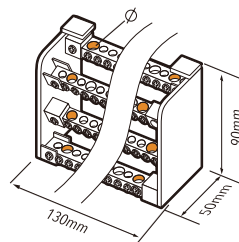

Model	LK-415	Amp=100A	LK-415B	Amp=125A
	UL94-V0		UL94-V0	
Flame retardant	4 poles	2x25mm ² /2xØ8.5mm	4 pole	11x6mm ² /11xØ5.5mm
Terminals per pole		7x6mm ² /7xØ5.5mm		2x25mm ² /2xØ7.5mm
		6x4mm ² /6xØ4.5mm		2x35mm ² /2xØ9mm



Performance:

- Compact space and highest capacity.
- Safe and easy electric connection.
- Protection: Transparent cover.
- Snap-on DIN Rail or mount to panel with screws.
- Halogen-free.
- Confirm to ROHS.
- Icc up to 35KA

Material:

- PA, Polyamide 66.UL94V-0 grade, inflaming ratarnding. good resist dissolve, good bounce impact force. Working Temperature: -40 °C~+110 °C;
- PC, Polycarbonate, good glossiness, inflaming retarding, good bounce impact force. and thermal stability is great. Working Temperature: -60 C~+135 °C;
- Brass (160A) , Copper (125A, 200A, 250A, 400A);
- Voltage: 690V;
- Color: clear/grey color.

SPECIFICATION

Model	Dimensions	Copper platoon size	Rated current	Nominal voltage	Phase	In/Out	IPK	Uimp
	mm	mm	A	V			KA	KV
LK34-160	180X138X74	17x8x147	160	690	4	1x120+4x80+8x65	20	5
LK34-1256	182X170X77	12x4x153	125	690	4	1xM8+5xM6	48	6
LK34-12511	280X170X77	12x4x248	125	690	4	1xM8+10xM6	30	6
LK34-12517	420X170X77	12x4x384	125	690	4	1xM8+16xM6	40	6
LK34-2006	182x170x77	15x4x153	200	690	4	1xM8+5xM6	48	6
LK34-20011	280x170x77	15x4x248	200	690	4	1xM8+10xM6	30	6
LK34-20017	420x170x77	15x4x384	200	690	4	1xM8+16xM6	40	6
LK34-2506	182x170x77	20x5x153	250	690	4	1xM8+5xM6	48	8
LK34-25011	280x170x77	20x5x248	250	690	4	1xM8+10xM6	30	8
LK34-25027	630x170x77	20x5x592	250	690	4	1xM8+26xM6	40	8
LK34-4006	182x150x116	25x6x153	400	690	4	1xM8+5xM6	48	8
LK34-40011	280x150x116	25x6x248	400	690	4	1xM8+10xM6	30	8
LK34-40017	420x150x116	25x6x384	400	690	4	1xM8+16xM6	40	8
LK34-40027	630x150x116	25x6x592	400	690	4	1xM8+26xM6	40	8

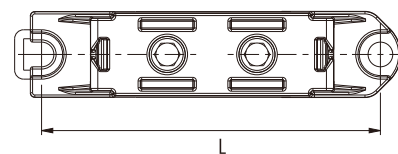
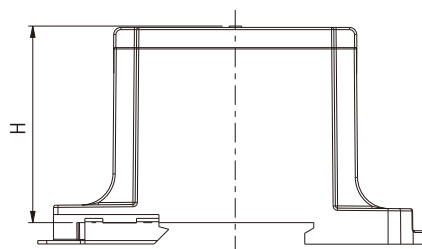
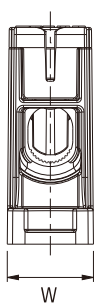
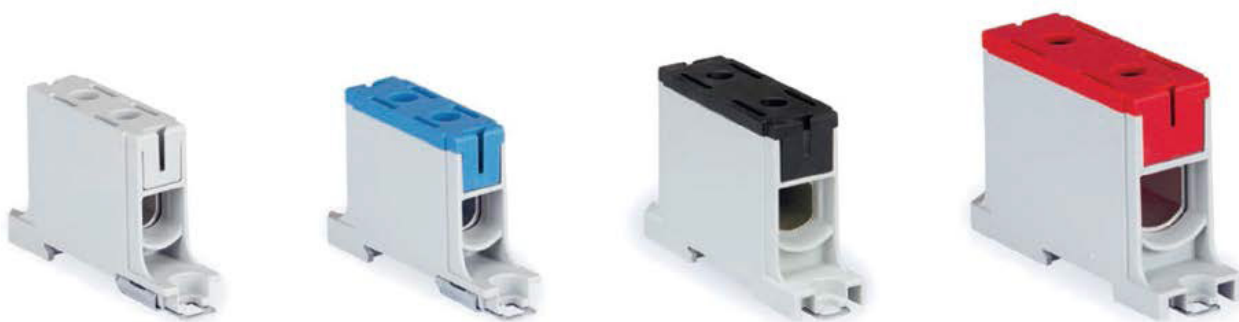

SPECIFICATION

Product Code	Color	Conductor	Nominal Voltage	Nominal Current	Tightening Torque	W×H×L	Weight	Package
		mm ²	V	A	Nm	(mm)	g	pcs
LK161	Grey ●	2.5-50	1000	Cu160 Al145	4Nm(2.5-4mm ²) 12Nm(6-50mm ²)	19.2x49x82.5	52	500
LK161.2	Blue ●							
LK161.4	Red ●							
LK161.6	Black ●							
LK162	Grey ●	16-95	1000	Cu245 Al220	10Nm(16-25mm ²) 20Nm(35-95mm ²)	25x56x93.6	112.5	240
LK162.2	Blue ●							
LK162.4	Red ●							
LK162.6	Black ●							
LK163	Grey ●	35-150	1000	Cu320 Al290	14Nm(35-95mm ²) 30Nm(120-150mm ²)	30.5x65x163	179	180
LK163.2	Blue ●							
LK163.4	Red ●							
LK163.6	Black ●							

DBK series MCB/MCCB terminal

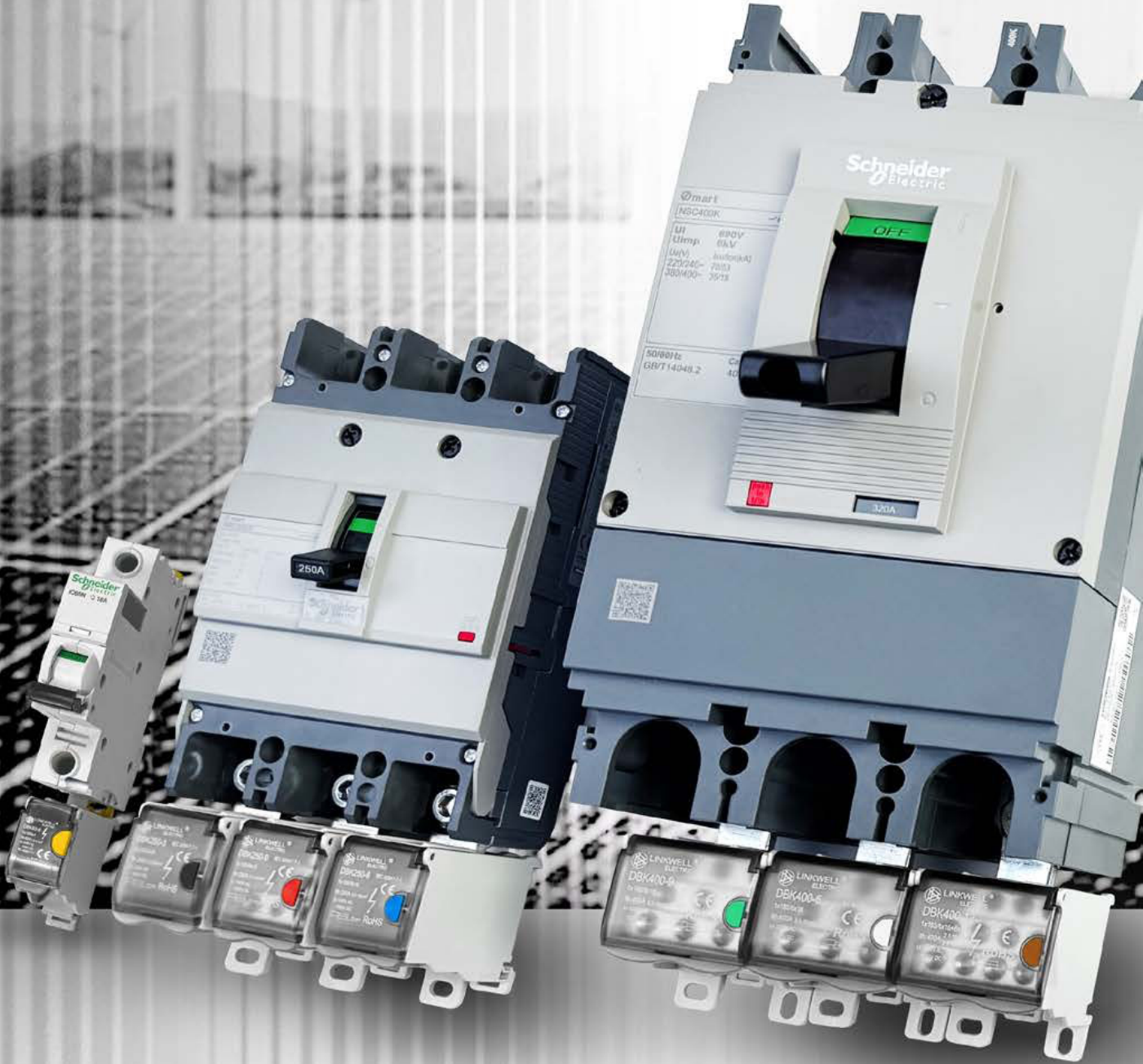

DBK63-3



■ DIMENSION (mm)

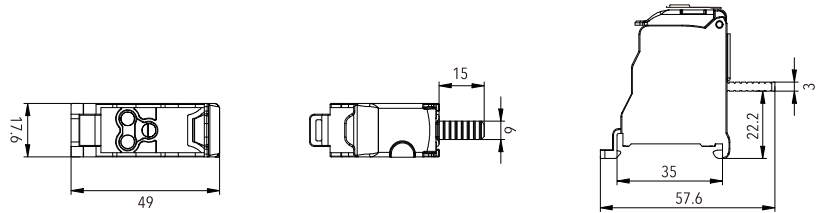

Model	Color marker kit	Output	Rated Current	Rated Voltage
DBK63-3 BU		3x6 mm ²	63A	1500V DC 1000V AC
DBK63-3 GN				
DBK63-3 BR				
DBK63-3 RD				
DBK63-3 BK				
DBK63-3 WH				
DBK63-3 YL				

DBK63-4



■ DIMENSION (mm)

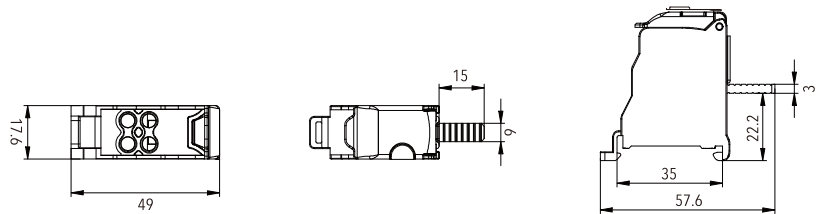

Model	Color marker kit	Output	Rated Current	Rated Voltage
DBK63-4 BU		4x6 mm ²	63A	1500V DC 1000V AC
DBK63-4 GN				
DBK63-4 BR				
DBK63-4 RD				
DBK63-4 BK				
DBK63-4 WH				
DBK63-4 YL				



DBK63-6

■ DIMENSION (mm)

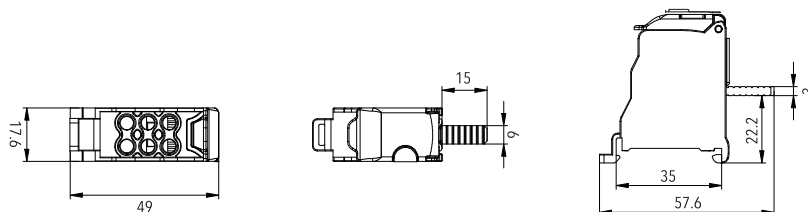

Model	Color marker kit	Output	Rated Current	Rated Voltage
DBK63-6 BU		6x4 mm ²	63A	1500V DC 1000V AC
DBK63-6 GN				
DBK63-6 BR				
DBK63-6 RD				
DBK63-6 BK				
DBK63-6 WH				
DBK63-6 YL				

DBK63-9

■ DIMENSION (mm)

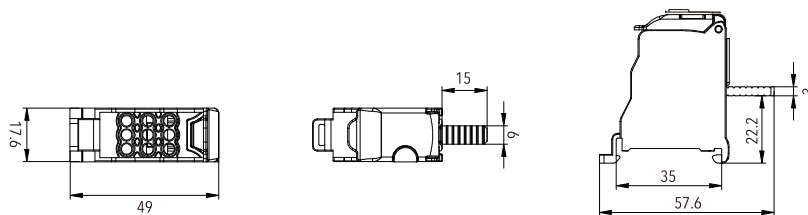

Model	Color marker kit	Output	Rated Current	Rated Voltage
DBK63-9 BU		9x2.5 mm ²	63A	1500V DC 1000V AC
DBK63-9 GN				
DBK63-9 BR				
DBK63-9 RD				
DBK63-9 BK				
DBK63-9 WH				
DBK63-9 YL				

DBK125-3



■ DIMENSION (mm)

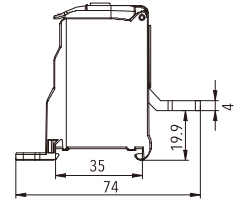
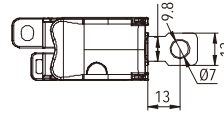
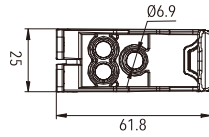

Model	Color marker kit	Output	Rated Current	Rated Voltage
DBK125-3 BU		3x16 mm ²	125A	1500V DC 1000V AC
DBK125-3 GN				
DBK125-3 BR				
DBK125-3 RD				
DBK125-3 BK				
DBK125-3 WH				
DBK125-3 YL				

DBK125-6



■ DIMENSION (mm)

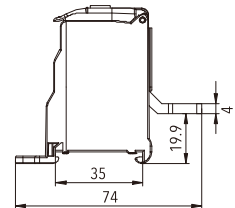
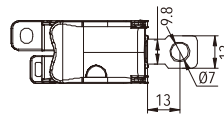
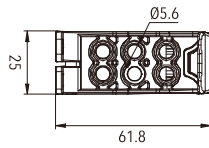

Model	Color marker kit	Output	Rated Current	Rated Voltage
DBK125-6 BU		6x10 mm ²	125A	1500V DC 1000V AC
DBK125-6 GN				
DBK125-6 BR				
DBK125-6 RD				
DBK125-6 BK				
DBK125-6 WH				
DBK125-6 YL				



DBK125-9

■ DIMENSION (mm)

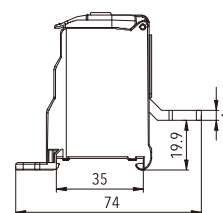
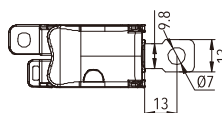
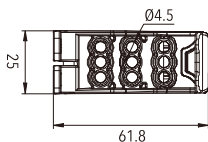

Model	Color marker kit	Output	Rated Current	Rated Voltage
DBK125-9 BU		9x6 mm ²	125A	1500V DC 1000V AC
DBK125-9 GN				
DBK125-9 BR				
DBK125-9 RD				
DBK125-9 BK				
DBK125-9 WH				
DBK125-9 YL				

DBK250-3

■ DIMENSION (mm)

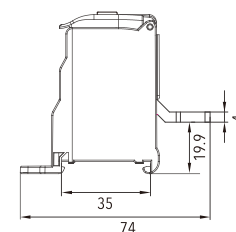
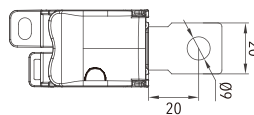
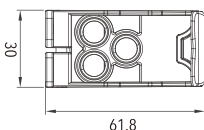

Model	Color marker kit	Output	Rated Current	Rated Voltage
DBK250-3 BU		3x25 mm ²	250A	1500V DC 1000V AC
DBK250-3 GN				
DBK250-3 BR				
DBK250-3 RD				
DBK250-3 BK				
DBK250-3 WH				
DBK250-3 YL				

DBK250-6



■ DIMENSION (mm)

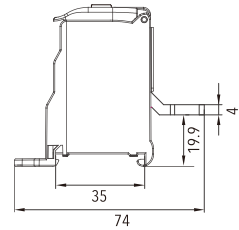
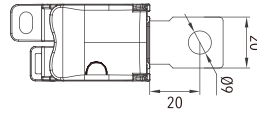
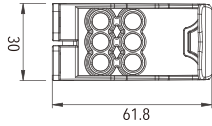

Model	Color marker kit	Output	Rated Current	Rated Voltage
DBK250-6 BU		6x16 mm ²	250A	1500V DC 1000V AC
DBK250-6 GN				
DBK250-6 BR				
DBK250-6 RD				
DBK250-6 BK				
DBK250-6 WH				
DBK250-6 YL				

DBK250-8



■ DIMENSION (mm)

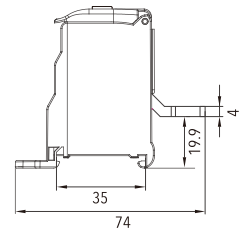
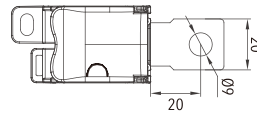
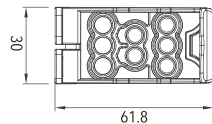

Model	Color marker kit	Output	Rated Current	Rated Voltage
DBK250-8 BU		8x16 mm ²	250A	1500V DC 1000V AC
DBK250-8 GN				
DBK250-8 BR				
DBK250-8 RD				
DBK250-8 BK				
DBK250-8 WH				
DBK250-8 YL				



DBK250-9

■ DIMENSION (mm)

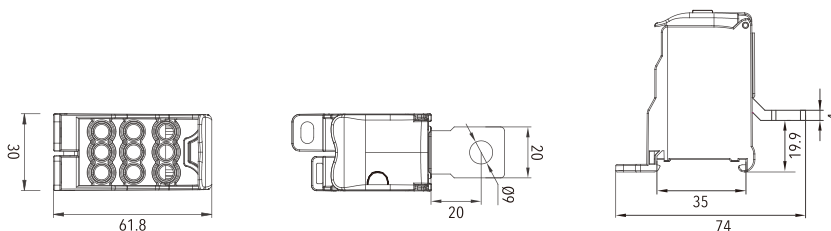

Model	Color marker kit	Output	Rated Current	Rated Voltage
DBK250-9 BU		9x10 mm ²	250A	1500V DC 1000V AC
DBK250-9 GN				
DBK250-9 BR				
DBK250-9 RD				
DBK250-9 BK				
DBK250-9 WH				
DBK250-9 YL				

DBK400-5

■ DIMENSION (mm)

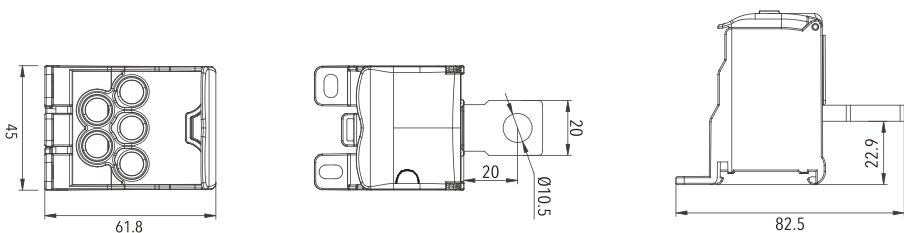

Model	Color marker kit	Output	Rated Current	Rated Voltage
DBK400-5 BU		5x25 mm ²	400A	1500V DC 1000V AC
DBK400-5 GN				
DBK400-5 BR				
DBK400-5 RD				
DBK400-5 BK				
DBK400-5 WH				
DBK400-5 YL				



DBK400-6

■ DIMENSION (mm)

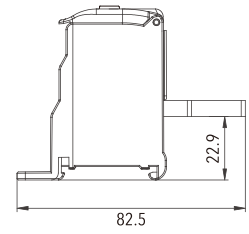
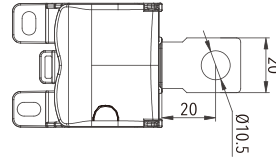
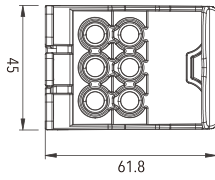

Model	Color marker kit	Output	Rated Current	Rated Voltage
DBK400-6 BU		6x16 mm ²	400A	1500V DC 1000VAC
DBK400-6 GN				
DBK400-6 BR				
DBK400-6 RD				
DBK400-6 BK				
DBK400-6 WH				
DBK400-6 YL				

DBK400-9

■ DIMENSION (mm)

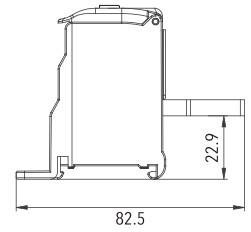
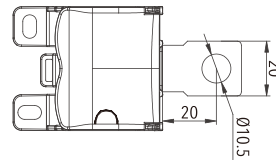
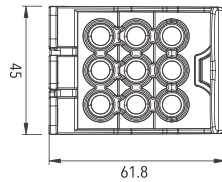

Model	Color marker kit	Output	Rated Current	Rated Voltage
DBK400-9 BU		9x16 mm ²	400A	1500V DC 1000VAC
DBK400-9 GN				
DBK400-9 BR				
DBK400-9 RD				
DBK400-9 BK				
DBK400-9 WH				
DBK400-9 YL				



DBK400-12

■ DIMENSION (mm)

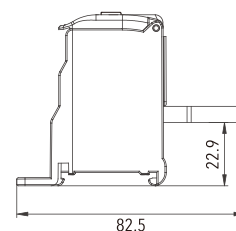
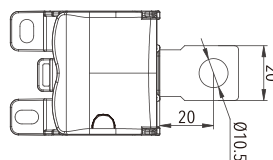
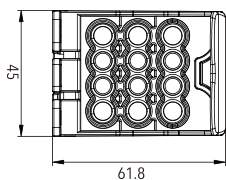

Model	Color marker kit	Output	Rated Current	Rated Voltage
DBK400-12 BU		6x16 mm ² 6x10 mm ²	400A	1500V DC 1000V AC
DBK400-12 GN				
DBK400-12 BR				
DBK400-12 RD				
DBK400-12 BK				
DBK400-12 WH				
DBK400-12 YL				



DBK400-18

■ DIMENSION (mm)

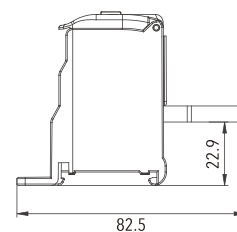
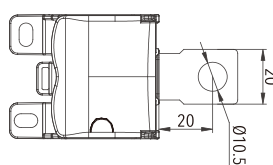
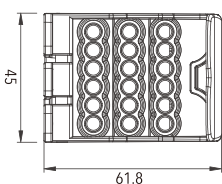

Model	Color marker kit	Output	Rated Current	Rated Voltage
DBK400-18 BU		18x6 mm ²	400A	1500V DC 1000V AC
DBK400-18 GN				
DBK400-18 BR				
DBK400-18 RD				
DBK400-18 BK				
DBK400-18 WH				
DBK400-18 YL				



DBK630-3

■ DIMENSION (mm)

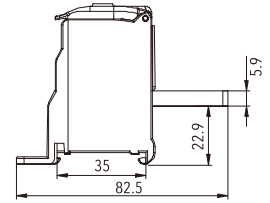
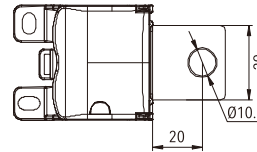
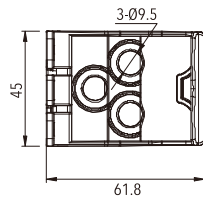

Model	Color marker kit	Output	Rated Current	Rated Voltage
DBK630-3 BU		3x50 mm ²	630A	1500V DC 1000V AC
DBK630-3 GN				
DBK630-3 BR				
DBK630-3 RD				
DBK630-3 BK				
DBK630-3 WH				
DBK630-3 YL				

DBK630-5

■ DIMENSION (mm)

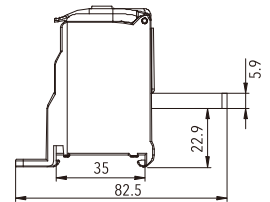
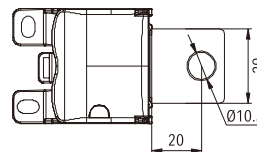
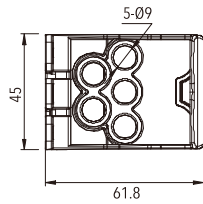

Model	Color marker kit	Output	Rated Current	Rated Voltage
DBK630-5 BU		5x35 mm ²	630A	1500V DC 1000V AC
DBK630-5 GN				
DBK630-5 BR				
DBK630-5 RD				
DBK630-5 BK				
DBK630-5 WH				
DBK630-5 YL				



DBK630-6

■ DIMENSION (mm)

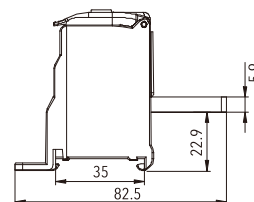
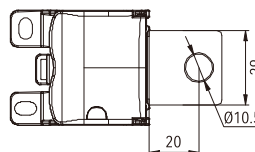
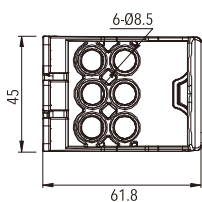

Model	Color marker kit	Output	Rated Current	Rated Voltage
DBK630-6 BU		6x25 mm ²	630A	1500V DC 1000V AC
DBK630-6 GN				
DBK630-6 BR				
DBK630-6 RD				
DBK630-6 BK				
DBK630-6 WH				
DBK630-6 YL				

DBK630-9

■ DIMENSION (mm)

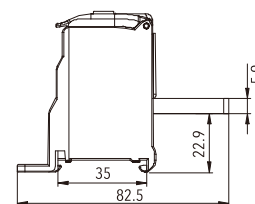
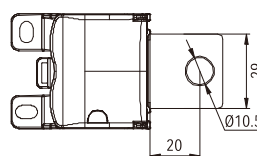
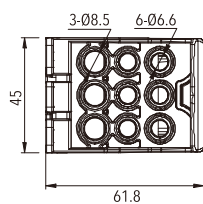







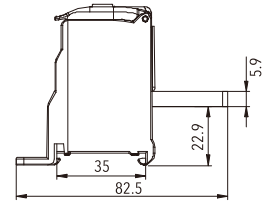
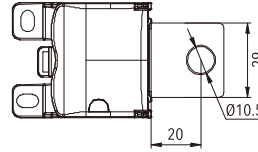
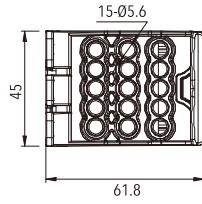

Model	Color marker kit	Output	Rated Current	Rated Voltage
DBK630-9 BU		6x16 mm ² 3x25 mm ²	630A	1500V DC 1000V AC
DBK630-9 GN				
DBK630-9 BR				
DBK630-9 RD				
DBK630-9 BK				
DBK630-9 WH				
DBK630-9 YL				



DBK630-15

■ DIMENSION (mm)



Model	Color marker kit	Output	Rated Current	Rated Voltage
DBK630-15 BU		15x10 mm ²	630A	1500V DC 1000V AC
DBK630-15 GN				
DBK630-15 BR				
DBK630-15 RD				
DBK630-15 BK				
DBK630-15 WH				
DBK630-15 YL				

KV225A



■ DIMENSION (mm)

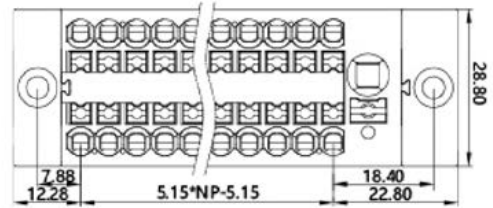
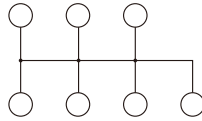

KV225B



■ DIMENSION (mm)

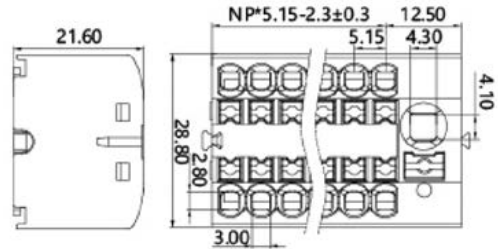
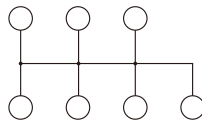

Model	Line diameters are divided into lines and main lines	Rated Voltage	Rated Current	Overvoltage Category / Pollution Degree			Rate Impulse Voltage	Poles	Pitch	Stripping length	Operating temperature	Number of poles
KV225A KV225B	0.2-4/0.5-6/10	690V	24/41A	III/3	III/2	II/2	4kV	N=02~12P	5.15mm	8-10mm	-40°C~105°C	1P/2P/3P/4P 5P/6P/7P/8P 9P/10P/11P/12P

KV225G



■ DIMENSION (mm)

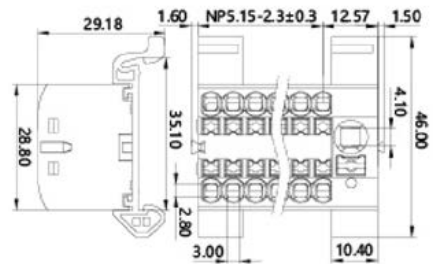
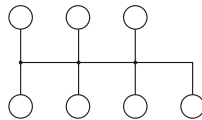

KV225H



■ DIMENSION (mm)

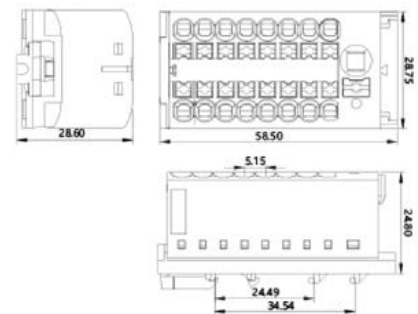
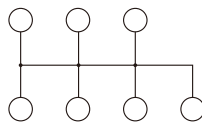

Model	Line diameters are divided into lines and main lines	Rated Voltage	Rated Current	Overvoltage Category / Pollution Degree			Rate Impulse Voltage	Poles	Pitch	Stripping length	Operating temperature	Number of poles
KV225G KV225H	0.2-4/0.5-6/10	690V	24/41A	III/3	III/2	II/2	4kV	N=02~12P	5.15mm	8-10mm	-40°C~105°C	1P/2P/3P/4P 5P/6P/7P/8P 9P/10P/11P/12P

KV225D-A



■ DIMENSION (mm)

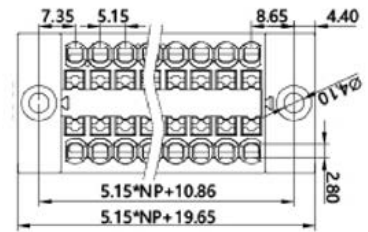
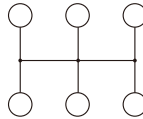

KV225D



■ DIMENSION (mm)

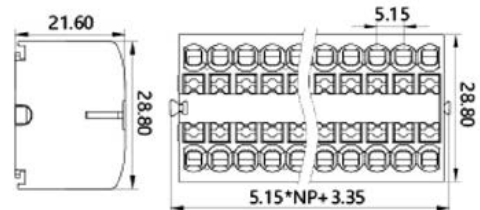
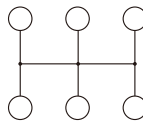

Model	Line diameters are divided into lines and main lines	Rated Voltage	Rated Current	Overvoltage Category Pollution Degree			Rate Impulse Voltage	Poles	Pitch	Stripping length	Operating temperature	Number of poles
KV225D-A KV225D	0.2-4/0.5-6/10	690V	24/41A	III/3	III/2	II/2	4kV	N=02~12P	5.15mm	8-10mm	-40°C~105°C	1P/2P/3P/4P 5P/6P/7P/8P 9P/10P/11P/12P

KV225D-G



■ DIMENSION (mm)

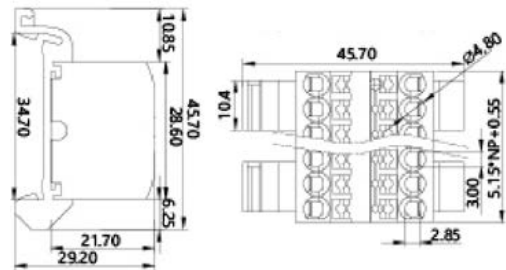
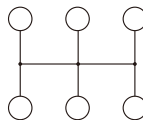

KV225D-H



■ DIMENSION (mm)

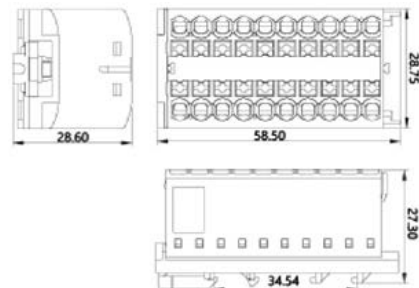
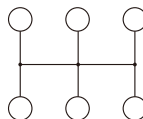

Model	Line diameters are divided into lines and main lines	Rated Voltage	Rated Current	Overvoltage Category Pollution Degree			Rate Impulse Voltage	Poles	Pitch	Stripping length	Operating temperature	Number of poles
KV225D-G KV225D-H	0.2-4/0.5-6/10	690V	24/41A	III/3	III/2	II/2	4kV	N=02~12P	5.15mm	8-10mm	-40°C~105°C	1P/2P/3P/4P 5P/6P/7P/8P 9P/10P/11P/12P

KV2251A



■ DIMENSION (mm)

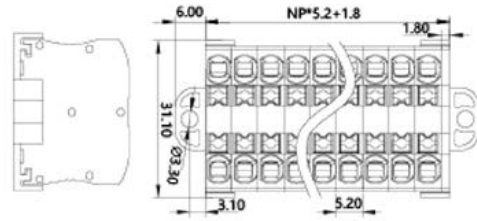
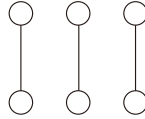

KV2251B



■ DIMENSION (mm)

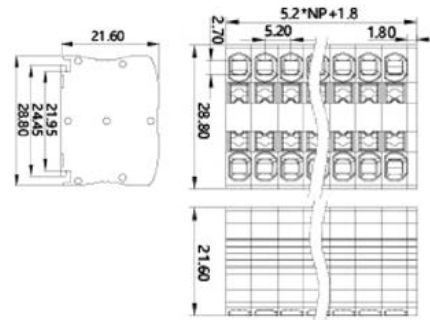
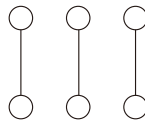

Model	Line diameters are divided into lines and main lines	Rated Voltage	Rated Current	Overvoltage Category Pollution Degree			Rate Impulse Voltage	Poles	Pitch	Stripping length	Operating temperature	Number of poles
KV2251A KV2251B	0.2-4	690V	32A	III/3	III/2	II/2	4kV	N=02~12P	5.15mm	8-10mm	-40°C~105°C	1P/2P/3P/4P 5P/6P/7P/8P 9P/10P/11P/12P

KV2251G



■ DIMENSION (mm)

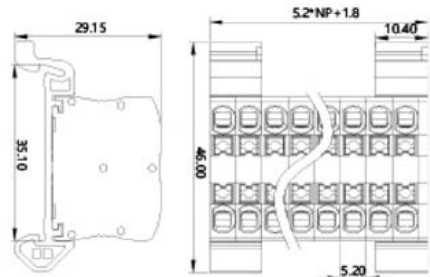
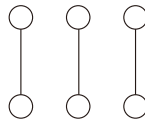

KV2251H



■ DIMENSION (mm)

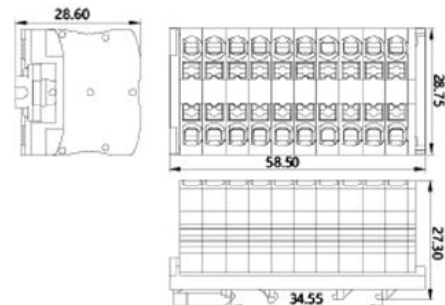
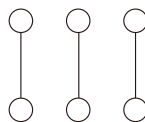

Model	Line diameters are divided into lines and main lines	Rated Voltage	Rated Current	Overvoltage Category Pollution Degree			Rate Impulse Voltage	Poles	Pitch	Stripping length	Operating temperature	Number of poles
KV2251G KV2251H	0.2-4	690V	32A	III/3	III/2	II/2	4kV	N=02~12P	5.15mm	8-10mm	-40°C~105°C	1P/2P/3P/4P 5P/6P/7P/8P 9P/10P/11P/12P



LINKWELL
ELECTRIC

KE UNIVERSAL TERMINAL FOR Al/CU CONDUCTORS

- Universal terminals are designed for copper and aluminium conductors. The terminals are suitable for all types of copper or aluminium conductors with cross-section up to 240mm².

Clip-in for markings (5 mm width)

Tightening torque labels on the connector cover

Class A short circuit tested

Higher 1000 V AC/DC voltage rating

Pre-greased contact area

Easier installation with conductor input collars

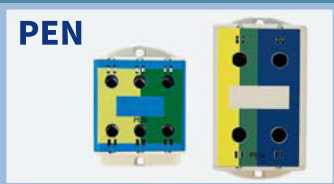

KE 60

16mm²-1 pole 2 holes

Dustproof cover can be added. Model KEPC016

■ DIMENSION (mm)

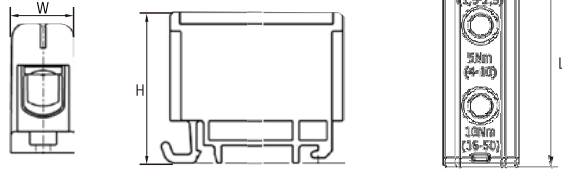

Product code	Color	Conductor mm ²	Nominal Voltage V	Nominal Current A	Tightenig Torque Nm	W×H×L (mm)	Weight g	Package pcs
KE60.1								
KE60.2		1.5-16	1000	Cu 85 Al 75	1.5Nm(1.5mm ²) 3.0Nm(2.5-16mm ²)	13.5×40×42	20	1000
KE60.3								



KE 70

16mm²-2 pole 4 holes

■ DIMENSION (mm)

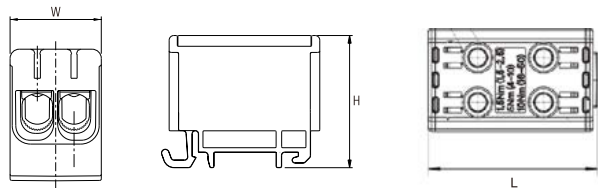

Product code	Color	Conductor mm ²	Nominal Voltage V	Nominal Current A	Tightenig Torque Nm	W×H×L (mm)	Weight g	Package pcs
KE70.1								
KE70.2		1.5-16	1000	Cu 85 Al 75	1.5Nm(1.5mm ²) 3.0Nm(2.5-16mm ²)	22×38.5×45	30.5	500
KE70.3								



KE 60.4

16mm²-3 pole 6 holes

■ DIMENSION (mm)

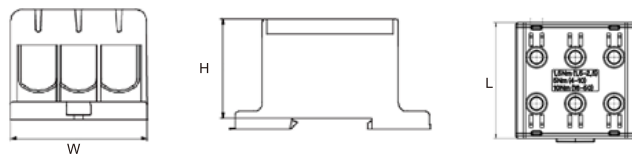

Product code	Color	Conductor mm ²	Nominal Voltage V	Nominal Current A	Tightenig Torque Nm	W×H×L (mm)	Weight g	Package pcs
KE60.4								
KE60.5		1.5-16	1000	Cu 85 Al 75	1.5Nm(1.5mm ²) 3.0Nm(2.5-16mm ²)	37.5×37.5×45.1	56	400
KE60.6								

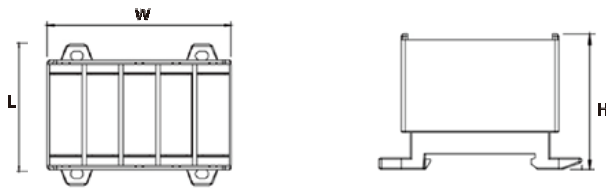

KE 60.7

16mm²-5 pole 10 holes
■ DIMENSION (mm)

Product code	Color	Conductor mm ²	Nominal Voltage V	Nominal Current A	Tightenig Torque Nm	W×H×L (mm)	Weight g	Package pcs
KE60.7		1.5-16	1000	Cu 85 Al 75	1.5Nm(1.5mm ²) 3.0Nm(2.5-16mm ²)	63×40×61.4	94	200



KE 50

35mm²-1 pole 2 holes

Dustproof cover can be added. Model KEPC035

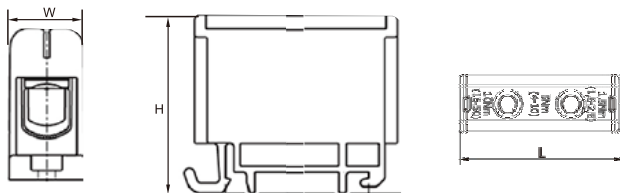
■ DIMENSION (mm)

Product code	Color	Conductor mm ²	Nominal Voltage V	Nominal Current A	Tightenig Torque Nm	W×H×L (mm)	Weight g	Package pcs
KE50.1								
KE50.2		2.5-35	1000	Cu 135 Al 120	3Nm(2.5-16mm ²) 6Nm(25-35mm ²)	16×40×46	24.5	500
KE50.3								

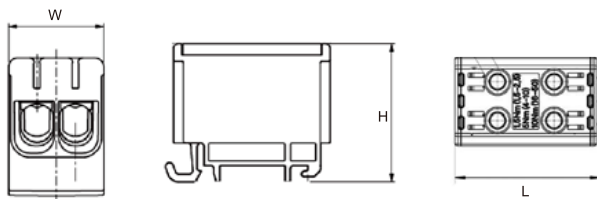

KE 65

35mm²-2 pole 4 holes
■ DIMENSION (mm)

Product code	Color	Conductor mm ²	Nominal Voltage V	Nominal Current A	Tightenig Torque Nm	W×H×L (mm)	Weight g	Package pcs
KE65.1								
KE65.2		2.5-35	1000	Cu 135 Al 120	3Nm(2.5-16mm ²) 6Nm(25-35mm ²)	27×40×46	42	300
KE65.3								



KE 50.4

35mm²-3 pole 6 holes



■ DIMENSION (mm)

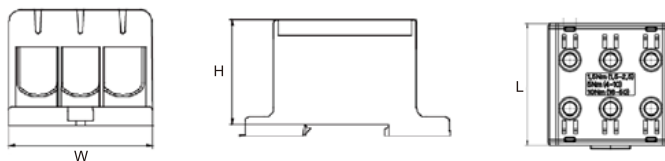

Product code	Color	Conductor mm ²	Nominal Voltage V	Nominal Current A	Tightenig Torque Nm	W×H×L (mm)	Weight g	Package pcs
KE50.4								
KE50.5		2.5-35	1000	Cu 135 Al 120	3Nm(2.5-16mm ²) 6Nm(25-35mm ²)	46×40×45.5	67	300
KE50.6								



KE 65.7

35mm²-5 pole 10 holes



■ DIMENSION (mm)

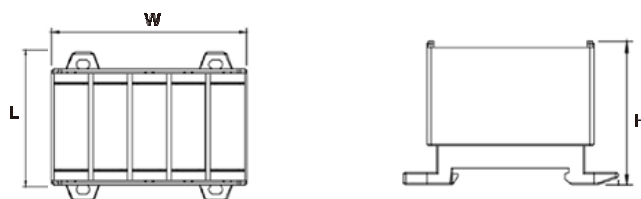

Product code	Color	Conductor mm ²	Nominal Voltage V	Nominal Current A	Tightenig Torque Nm	W×H×L (mm)	Weight g	Package pcs
KE65.7		2.5-35	1000	Cu 135 Al 120	3Nm(2.5-16mm ²) 6Nm(25-35mm ²)	80×40×62	114	200



KE 61

50mm²-1 pole 2 holes

Dustproof cover can be added. Model KEPC050

■ DIMENSION (mm)

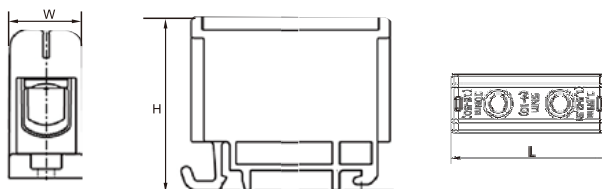

Product code	Color	Conductor mm ²	Nominal Voltage V	Nominal Current A	Tightenig Torque Nm	W×H×L (mm)	Weight g	Package pcs
KE61.1								
KE61.2		2.5-50	1000	Cu 160 Al 145	4Nm(2.5-4mm ²) 12Nm(6-50mm ²)	17.8×43×49	35	500
KE61.3								



KE 66

50mm²-2 pole 4 holes

■ DIMENSION (mm)

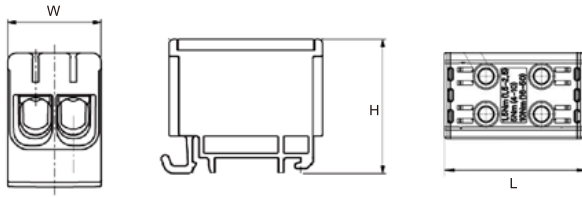

Product code	Color	Conductor mm ²	Nominal Voltage V	Nominal Current A	Tightenig Torque Nm	W×H×L (mm)	Weight g	Package pcs
KE66.1								
KE66.2		2.5-50	1000	Cu 160 Al 145	4Nm(2.5-4mm ²) 12Nm(6-50mm ²)	29.8×43×49	61	300
KE66.3								



KE 71

50mm²-3 pole 6 holes

■ DIMENSION (mm)

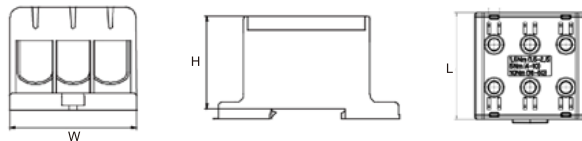

Product code	Color	Conductor mm ²	Nominal Voltage V	Nominal Current A	Tightenig Torque Nm	W×H×L (mm)	Weight g	Package pcs
KE71.1								
KE71.2		2.5-50	1000	Cu 245 Al 220	4Nm(2.5-4mm ²) 12Nm(6-50mm ²)	49×43×48	100.5	185
KE71.3								



KE 61

50mm²-3 pole 6 holes

■ DIMENSION (mm)

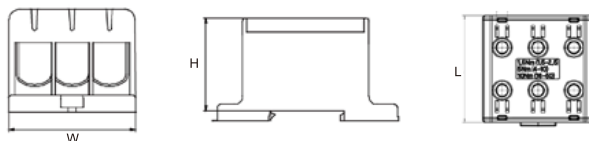

Product code	Color	Conductor mm ²	Nominal Voltage V	Nominal Current A	Tightenig Torque Nm	W×H×L (mm)	Weight g	Package pcs
KE61.4								
KE61.5		2.5-50	1000	Cu 160 Al 145	4Nm(2.5-4mm ²) 12Nm(6-50mm ²)	49×43×48	100.5	185
KE61.6								



KE 61

50mm²-5 pole 10 holes

■ DIMENSION (mm)

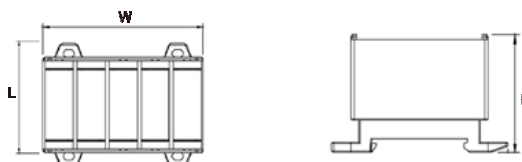

Product code	Color	Conductor mm ²	Nominal Voltage V	Nominal Current A	Tightening Torque Nm	W×H×L (mm)	Weight g	Package pcs
KE61.7		2.5-50	1000	Cu 160 Al 145	4Nm(2.5-4mm ²) 12Nm(6-50mm ²)	86×44×51	161.5	200



KE 62

95mm²-1 pole 2 holes

Dustproof cover can be added. Model KEPC095

■ DIMENSION (mm)

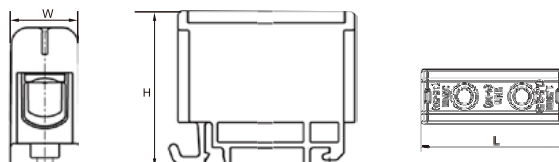

Product code	Color	Conductor mm ²	Nominal Voltage V	Nominal Current A	Tightening Torque Nm	W×H×L (mm)	Weight g	Package pcs
KE62.1		16-95	1000	Cu 245 Al 220	10Nm(16-25mm ²) 20Nm(35-95mm ²)	24×49×86	95	240



KE 67

95mm²-2 pole 4 holes

■ DIMENSION (mm)

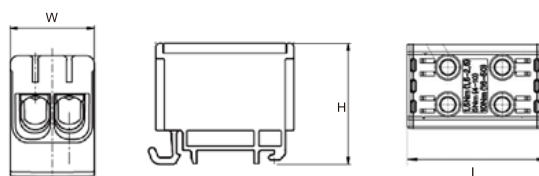

Product code	Color	Conductor mm ²	Nominal Voltage V	Nominal Current A	Tightening Torque Nm	W×H×L (mm)	Weight g	Package pcs
KE67.1		16-95	1000	Cu 245 Al 220	10Nm(16-25mm ²) 20Nm(35-95mm ²)	42×49×86	172.5	90



KE 72

95mm²-3 pole 6 holes

■ DIMENSION (mm)

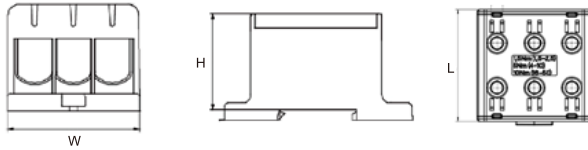

Product code	Color	Conductor mm ²	Nominal Voltage V	Nominal Current A	Tightenig Torque Nm	W×H×L (mm)	Weight g	Package pcs
KE72.1								
KE72.2		16-95	1000	Cu 320 Al 290	10Nm(16-25mm ²) 20Nm(35-95mm ²)	51.5×59×95	245	90
KE72.3								



KE 63

150mm²-1 pole 2 holes

Dustproof cover can be added. Model KEPC150

■ DIMENSION (mm)

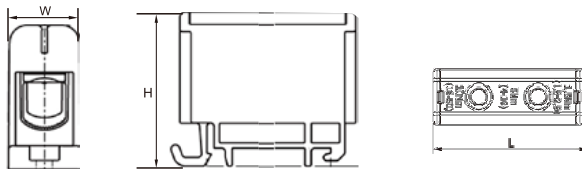

Product code	Color	Conductor mm ²	Nominal Voltage V	Nominal Current A	Tightenig Torque Nm	W×H×L (mm)	Weight g	Package pcs
KE63.1								
KE63.2		35-150	1000	Cu 320 Al 290	14Nm(35-95mm ²) 30Nm(120-150mm ²)	29.5×59×95	163.5	180
KE63.3								



KE 68

150mm²-2 pole 4 holes

■ DIMENSION (mm)

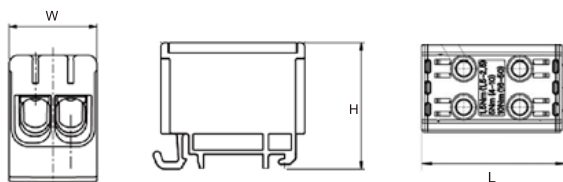

Product code	Color	Conductor mm ²	Nominal Voltage V	Nominal Current A	Tightenig Torque Nm	W×H×L (mm)	Weight g	Package pcs
KE68.1								
KE68.2		35-150	1000	Cu 320 Al 290	14Nm(35-95mm ²) 30Nm(120-150mm ²)	51.5×59×95	290.5	90
KE68.3								



KE 73

150mm²-3 pole 6 holes

■ DIMENSION (mm)

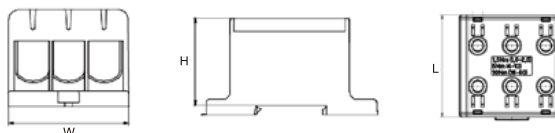

Product code	Color	Conductor mm ²	Nominal Voltage V	Nominal Current A	Tightenig Torque Nm	W×H×L (mm)	Weight g	Package pcs
KE73.1								
KE73.2		35-150	1000	Cu 425 Al 380	14Nm(35-95mm ²) 30Nm(120-150mm ²)	64×67×130	426	60
KE73.3								



KE 64

240mm²-1 pole 2 holes

Dustproof cover can be added. Model KEPC240

■ DIMENSION (mm)

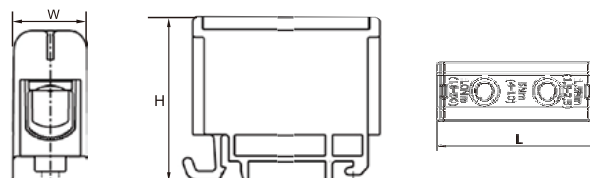

Product code	Color	Conductor mm ²	Nominal Voltage V	Nominal Current A	Tightenig Torque Nm	W×H×L (mm)	Weight g	Package pcs
KE64.1								
KE64.2		35-240	1000	Cu 425 Al 380	12Nm(35-70mm ²) 45Nm(95-240mm ²)	37.5×67×130	318	100
KE64.3								



KE 69

240mm²-2 pole 4 holes

■ DIMENSION (mm)

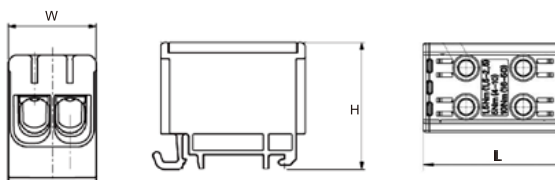

Product code	Color	Conductor mm ²	Nominal Voltage V	Nominal Current A	Tightenig Torque Nm	W×H×L (mm)	Weight g	Package pcs
KE69.1								
KE69.2		35-240	1000	Cu 425 Al 380	12Nm(35-70mm ²) 45Nm(95-240mm ²)	64×67×130	566.5	90
KE69.3								



KE 74

240mm²-3 pole 6 holes

■ DIMENSION (mm)

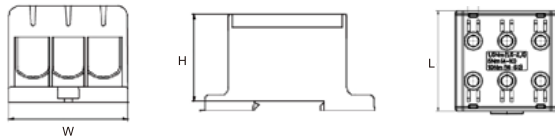

Product code	Color	Conductor mm ²	Nominal Voltage V	Nominal Current A	Tightenig Torque Nm	W×H×L (mm)	Weight g	Package pcs
KE74.1								
KE74.2		35-240	1000	Cu 425 Al 380	12Nm(35-70mm ²) 45Nm(95-240mm ²)	94×67×130	850	30
KE74.3								



KEPC Protection Covers

KE Universal terminal for AL/CU conductors



SPECIFICATION

Model	Description
KEPC016	Prtection cover for KE 16mm ²
KEPC035	Prtection cover for KE 35mm ²
KEPC050	Prtection cover for KE 50mm ²
KEPC095	Prtection cover for KE 95mm ²
KEPC0150	Prtection cover for KE 150mm ²
KEPC0240	Prtection cover for KE 240mm ²

PT series push in terminal block

Order number ●

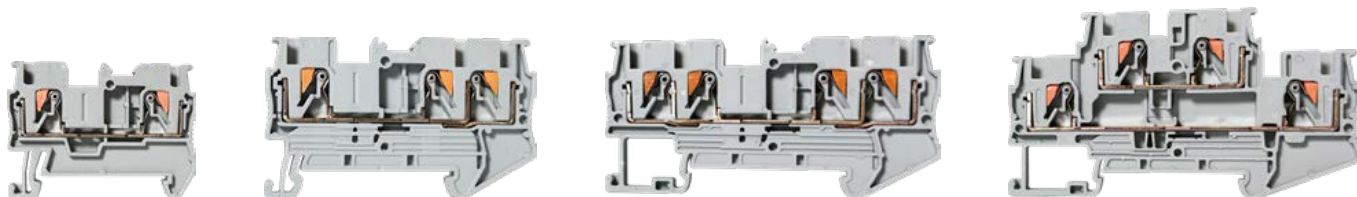

PT 2.5

PT 2.5-TW

PT 2.5-QU

PTTB 2.5

SPECIFICATION

Model	Dimensions	Current Voltage	Marker	Solid wire Stranded wire	End cover	Plug-in-bridge	End damp
	WxLxH (mm)	[A] / [V]					
PT 1.5/S	3.5x45x30.5	17.5/500	ZB 3.5	0.14-1.5/26-14 0.14-1.5/26-14	D-PT 1.5/S	FBS 2-3.5 FBS 3-3.5 FBS 5-3.5 FBS 10-3.5	
PT 2.5	5.2x48.6x35.3	24/800	ZB 5	0.14-4/26-12 0.14-2.5/26-14	D-PT 2.5	FBS 2-5 FBS 3-5 FBS 5-5 FBS 10-5	
PT 4	6.2x56x35.3	32/800	ZB 6	0.2-6/24-10 0.2-4/24-12	D-PT 4	FBS 2-6 FBS 3-6 FBS 5-6 FBS 10-6	
PT 6	8.2x57.7x42.2	41/1000	ZB 8	0.5-10/20-8 0.5-6/20-10	D-PT 6	FBS 2-8 FBS 3-8 FBS 5-8 FBS 10-8	
PT 10	10.2x67.7x49.5	57/1000	ZB 10	0.5-16/20-6 0.5-10/20-8	D-PT 10	FBS 2-10 FBS 3-10 FBS 5-10 FBS 10-10	E/LUK EB3
PT 16	12.2x75.4x53	76/1000	ZB 1	0.5-25/20-4 0.5-16/20-6	D-PT 16	FBS 2-12 FBS 3-12 FBS 5-12 FBS 10-12	
PT 1.5-TW	3.5x30.5x54	17.5/500	ZB 3.5	0.14-1.5/26-14 0.14-1.5/26-14	D-PT 1.5-TW	FBS 2-3.5 FBS 3-3.5 FBS 5-3.5 FBS 10-3.5	
PT 2.5-TW	5.2x35.3x60.5	24/800	ZB 5	0.14-4/26-12 0.14-2.5/26-14	D-PT 2.5-TW	FBS 2-5 FBS 3-5 FBS 5-5 FBS 10-5	
PT 4-TW	6.2x25.3x66.5	32/800	ZB 6	0.2-6/24-10 0.2-4/24-12	D-PT 4-TW	FBS 2-6 FBS 3-6 FBS 5-6 FBS 10-6	

SPECIFICATION

Model	Dimensions	Current Voltage	Marker	Solid wire Stranded wire	End cover	Plug-in-bridge	End clamp
	WxLxH (mm)	[A] / [V]					
PT 1.5-QU	3.5x30.5x63.2	17.5/500	ZB 3.5	0.14-1.5/26-14 0.14-1.5/26-14	D-PT 1.5-QU	FBS 2-3.5 FBS 3-3.5 FBS 5-3.5 FBS 10-3.5	E/LUK EB3
PT 2.5-QU	5.2x35.3x72.2	24/800	ZB 5	0.14-4/26-12 0.14-2.5/26-14	D-PT 2.5-QU	FBS 2-5 FBS 3-5 FBS 5-5 FBS 10-5	
PT 4-QU	6.2x35.3x77	32/800	ZB 6	0.2-6/24-10 0.2-4/24-12	D-PT 4-QU	FBS 2-6 FBS 3-6 FBS 5-6 FBS 10-6	
PTTB 1.5	3.5x41.1x65.4	17.5/500	ZBFM 3.5	0.14-1.5/26-14 0.14-1.5/26-14	D-PTTB 1.5	FBS 2-3.5 FBS 3-3.5 FBS 5-3.5 FBS 10-3.5	
PTTB 2.5	5.2x45.8x68	24/800	ZBFM 5	0.14-4/26-12 0.14-2.5/26-14	D-PTTB 2.5	FBS 2-5 FBS 3-5 FBS 5-5 FBS 10-5	
PTTB 4	6.2x47.5x83.5	32/800	ZBFM 60	0.2-6/24-10 0.2-4/24-12	D-PTTB 4	FBS 2-6 FBS 3-6 FBS 5-6 FBS 10-6	



PTV 2.5

PTU 6-T

PT 4-HESI

PT 2.5-3L

SPECIFICATION

Order number ● ●

Model	Dimensions WxLxH (mm)	Current Voltage [A] / [V]	Marker	Solid wire Stranded wire	End cover	End clamp
PTV 2.5	5.2x35.3x50.8	24/800	ZBFM 5	0.14-4/26-12 0.14-2.5/26-14	D-PTV 2.5	E/LUK EB3
PTU 6-T	8.2x48x73.9	41/500	ZB 8	0.5-10/20-8 0.5-6/20-10	D-PTU 6	
PT 4-HESI	8.2x35.3x67.8	6.3/500	ZB 6	0.2-6/24-10 0.2-4/24-12	D-PTC 4	
PT 2.5-3L	5.2x56.4x102	20/500	ZBFM 5	0.14-4/26-12 0.14-2.5/26-14	D-PT 2.5-3L	

PT series push in terminal block

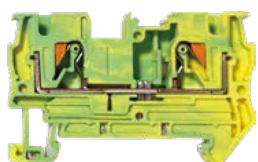

PT 4-PE

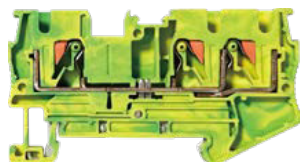

PT 4-TWIN-PE

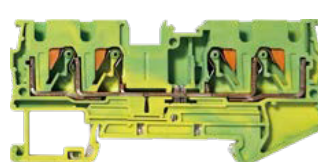

PT 4-QU-PE

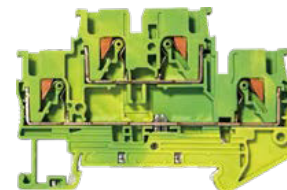

PTTB 2.5-PE

SPECIFICATION

Model	Dimensions WxLxH (mm)	Solid wire Stranded wire	Marker	End cover	End clamp
PT 2.5-PE	5.2x35.3x48.6	0.14-4/26-12 0.14-2.5/26-14	ZB 5	D-PT 2.5	E/LUK EB3
PT 4-PE	6.2x35.3x56	0.2-6/24-10 0.2-4/24-12	ZB 6	D-PT 4	
PT 6-PE	8.2x42.2x57.7	0.5-10/20-8 0.5-6/20-10	ZB 8	D-PT 6	
PT 10-PE	10.2x49.5x67.7	0.5-16/20-6 0.5-10/20-8	ZB 10	D-PT 10	
PTTB 2.5-PE	5.2x45.8x68	0.14-4/26-12 0.14-2.5/26-14	ZBFM 5	D-PTTB 2.5	
PTTB 4-PE	6.2x47.5x83.5	0.2-6/24-10 0.2-4/24-12	ZBFM 6	D-PTTB 4	
PT 2.5-TWIN-PE	5.2x35.3x60.5	0.14-4/26-12 0.14-2.5/26-14	ZB 5	D-PT 2.5-TW	
PT 4-TWIN-PE	6.2x25.3x66.5	0.2-6/24-10 0.2-4/24-12	ZB 6	D-PT 4-TW	
PT 2.5-QU-PE	5.2x35.3x72.5	0.14-4/26-12 0.14-2.5/26-14	ZB 5	D-PT 2.5-QU	
PT 4-QU-PE	6.2x35.3x77	0.2-6/24-10 0.2-4/24-12	ZB 6	D-PT 4-QU	



LUK 2.5B

Size: T6.2xH40.6xW42.6mm
Rigid wire: 0.2-4mm²
Flexible wire: 0.2-2.5mm²
With mark bar: ZB6

32A 800V



IEC 60947-7-1



Parameters

End plate: thickness 1.5mm grey	D-LUK 2.5	
Fixed bridge: 2poles 3poles	FBI10-6	
Insertion bridge poles: 2poles 3poles 10poles	EB2-6; EB3-6; EB10-6	
Switching jumper: complete set, need to add end cover between the two terminals	LUSBR2-7	
Diaphragms: used for electrical isolation between adjacent bridges; insert after the fact; no space	-	
Partition plate: T1.5mm	ATP-LUK	
End clamp	E/LUK	



LUK 3N

Size: T5.2xH46xW42.7mm
Rigid wire: 0.2-4mm²
Flexible wire: 0.2-2.5mm²
With mark bar: ZB5

32A 800V



IEC 60947-7-1



Parameters

End plate: thickness 1.5mm grey	D-LUK4/10	
Fixed bridge: 2poles 3poles	FBI10-5	
Insertion bridge poles: 2poles 3poles 10poles	EB2-5; EB3-5; EB10-5	
Switching jumper: complete set, need to add end cover between the two terminals	-	
Diaphragms: used for electrical isolation between adjacent bridges; insert after the fact; no space	TS-K	
Partition plate: T1.5mm	-	
End clamp	E/LUK	



LUK 5N

Size: T6.2xH46.2xW42.6mm
Rigid wire: 0.2-6mm²
Flexible wire: 0.2-4mm²
With mark bar: ZB6

41A 800V



IEC 60947-7-1



Parameters

End plate: thickness 1.5mm grey	D-LUK4/10	
Fixed bridge: 2poles 3poles	FBI10-6	
Insertion bridge poles: 2poles 3poles 10poles	EB2-6; EB3-6; EB10-6	
Switching jumper: complete set, need to add end cover between the two terminals	LUSBR2-7	
Diaphragms: used for electrical isolation between adjacent bridges; insert after the fact; no space	TS-K	
Partition plate: T1.5mm	ATP-LUK	
End clamp	E/LUK	



LUK 6N







57A 800V

Size: T8.2xH46xW42.7mm

Rigid wire: 0.2-10mm²
Flexible wire: 0.2-6mm²
With mark bar: ZB8

IEC 60947-7-1

Parameters

End plate: thickness 1.5mm grey	D-LUK4/10	
Fixed bridge: 2poles 3poles	FBI10-8	
Insertion bridge poles: 2poles 3poles 10poles	EB2-8; EB3-8; EB10-8	
Switching jumper: complete set, need to add end cover between the two terminals	LUSBR2-8/13	
Diaphragms: used for electrical isolation between adjacent bridges; insert after the fact; no space	TS-K	
Partition plate: T1.5mm	ATP-LUK	
End clamp	E/LUK	



LUK 10N







76A 800V

Size: T10.2xH42.8xW42.5mm

Rigid wire: 0.5-16mm²
Flexible wire: 0.5-10mm²
With mark bar: ZB10

IEC 60947-7-1

Parameters

End plate: thickness 1.5mm grey	D-LUK4/10	
Fixed bridge: 2poles 3poles	FBI10-10	
Insertion bridge poles: 2poles 3poles 10poles	EB2-10; EB3-10; EB10-10	
Switching jumper: complete set, need to add end cover between the two terminals	-	
Diaphragms: used for electrical isolation between adjacent bridges; insert after the fact; no space	TS-K	
Partition plate: T1.5mm	ATP-LUK	
End clamp	E/LUK	



LUK 16N







100A 800V

Size: T12.2xH52.2xW42.5mm

Rigid wire: 2.5-25mm²
Flexible wire: 4-16mm²
With mark bar: ZB10

IEC 60947-7-1

Parameters

End plate: thickness 1.5mm grey	D-LUK16	
Fixed bridge: 2poles 3poles	FBI10-12	
Insertion bridge poles: 2poles 3poles 10poles	EB2-12; EB3-12; EB10-12	
Switching jumper: complete set, need to add end cover between the two terminals	-	
Diaphragms: used for electrical isolation between adjacent bridges; insert after the fact; no space	TS-K	
Partition plate: T1.5mm	ATP-LUK	
End clamp	E/LUK	



LUK 35N

125A 800V



Size: T15.2xH52.7xW50.7mm
Rigid wire: 10-35mm²
Flexible wire: 10-35mm²
With mark bar: ZB10

IEC 60947-7-1



Parameters

End plate: thickness 1.5mm grey	-	
Fixed bridge: 2poles 3poles	FBI2-15; FBI3-15	
Insertion bridge poles: 2poles 3poles 10poles	EB2-15; EB3-15; EB10-15	
Switching jumper: complete set, need to add end cover between the two terminals	-	
Diaphragms: used for electrical isolation between adjacent bridges; insert after the fact; no space	TS-K	
Partition plate: T1.5mm	-	
End clamp	E/LUK	

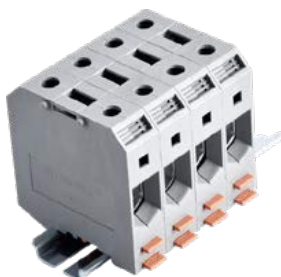

LUKH 50

150A 1000V



Size: T20xH76.2xW71.2mm
Rigid wire: 16-50mm²
Flexible wire: 25-50mm²
With mark bar: ZB10

IEC 60947-7-1



Parameters

Edge insertion stub: Fully insulated, inserted into the terminal clamp body and embedded in the terminal housing, 2 bits; 3-bit	-	
Aluminium alloy	E/AL-NS 35	

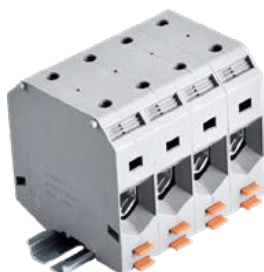

LUKH 95

232A 1000V



Size: T25xH91xW83.9mm
Rigid wire: 25-95mm²
Flexible wire: 35-95mm²
With mark bar: ZB10

IEC 60947-7-1



Parameters

Edge insertion stub: Fully insulated, inserted into the terminal clamp body and embedded in the terminal housing, 2 bits; 3-bit	EB2-25; EB3-25	
Aluminium alloy	E/AL-NS 35	



LUKH 150

309A 1000V



Size: T31.5xH111.2xW100.1mm
Rigid wire: 35-150mm²
Flexible wire: 50-150mm²
With mark bar: ZB10

IEC 60947-7-1



Parameters

Edge insertion stub: Fully insulated, inserted into the terminal clamp body and embedded in the terminal housing, 2 bits; 3-bit	-	
Aluminium alloy	E/AL-NS 35	



LUKH 240

415A 1000V





Size: T36xH122.5xW101.5mm
Rigid wire: 70-240mm²
Flexible wire: 70-240mm²
With mark bar: ZB10

IEC 60947-7-1



Parameters

Edge insertion stub: Fully insulated, inserted into the terminal clamp body and embedded in the terminal housing, 2 bits; 3-bit	-	
Aluminium alloy	E/AL-NS 35	



LUKK 3

32A 500V







Size: T5.2xH61.4xW56.8mm
Rigid wire: 0.2-4mm²
Flexible wire: 0.2-2.5mm²
With mark bar: ZB5

IEC 60947-7-1



Parameters

End cover: grey	D-LUKK3/5	
Space compensation plate: used to offset ingterlayer misalignment when placed adjacent to a normal terminal: thicknes 2.5mm gray	DG-LUKK3/5	
Space compensation plate: used to offset ingterlayer misalignment when placed adjacent to a normal terminal: thickness 2.5mm	DP-LUKK3/5	
Insertion bridge poles: 2 poles 10 poles	EB2-5; EB3-5; EB10-5	
With insulation pads bridge pieces: 10 poles, divisible, 10 screws, in order to form a jumper that skips some of the terminals, it needs to be padded	FBI10-5	



LUKK 5

32A 500V







Size: T6.2xH61.2xW56.5mm
Rigid wire: 0.2-4mm²
Flexible wire: 0.2-4mm²
With mark bar: ZB6

IEC 60947-7-1



Parameters

End cover: grey	D-LUKK3/5	
Space compensation plate: used to offset ingterlayer misalignment when placed adjacent to a normal terminal: thicknes 2.5mm gray	DG-LUKK3/5	
Space compensation plate: used to offset ingterlayer misalignment when placed adjacent to a normal terminal: thickness 2.5mm	DP-LUKK3/5	
Insertion bridge poles: 2 poles 10 poles	EB2-6; EB3-6; EB10-6	
With insulation pads bridge pieces: 10 poles, divisible, 10 screws, in order to form a jumper that skips some of the terminals, it needs to be padded	FBI10-6	

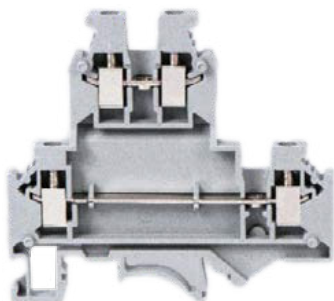

LUKKB 3

32A 500V



Size: T5.8xH61.2xW67.7mm
Rigid wire: 0.2-4mm²
Flexible wire: 0.2-2.5mm²
With mark bar: ZB5

IEC 60947-7-1



Parameters

End cover: grey	D-LUKKB3/5	
Space compensation plate: used to offset interlayer misalignment when placed adjacent to a normal terminal: thickness 2.5mm gray	DG-LUKKB3/5	
Space compensation plate: used to offset interlayer misalignment when placed adjacent to a normal terminal: thickness 2.5mm	DP-LUKKB3/5	
Insertion bridge poles: 2 poles 10 poles	EB2-5; EB3-5; EB10-5	
With insulation pads bridge pieces: 10 poles, divisible, 10 screws, in order to form a jumper that skips some of the terminals, it needs to be padded	FBI10-5	
End damp: suitable for mounting rails of type or for supporting double deck	E/LUK	

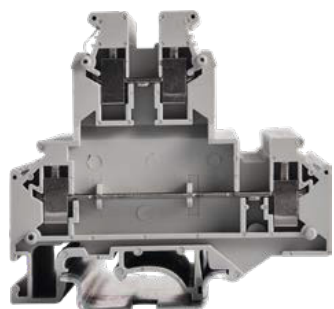

LUKKB 5

32A 500V



Size: T6.3xH61.2xW67.6mm
Rigid wire: 0.2-4mm²
Flexible wire: 0.2-2.5mm²
With mark bar: ZB6

IEC 60947-7-1



Parameters

End cover: grey	D-LUKKB3/5	
Space compensation plate: used to offset interlayer misalignment when placed adjacent to a normal terminal: thickness 2.5mm gray	DG-LUKKB3/5	
Space compensation plate: used to offset interlayer misalignment when placed adjacent to a normal terminal: thickness 2.5mm	DP-LUKKB3/5	
Insertion bridge poles: 2 poles 10 poles	EB2-6; EB3-6; EB10-6	
With insulation pads bridge pieces: 10 poles, divisible, 10 screws, in order to form a jumper that skips some of the terminals, it needs to be padded	FBI10-6	
End damp: suitable for mounting rails of type or for supporting double deck	E/LUK	



LMBKK 2.5

24A 500V



Size: T5.2xH47.4xW61.9mm
Rigid wire: 0.2-4mm²
Flexible wire: 0.2-2.5mm²
With mark bar: ZB5

IEC 60947-7-1



Parameters

End cover: grey	D-LMBKK2.5	
Space compensation plate: used to offset interlayer misalignment when placed adjacent to a normal terminal: thickness 2.5mm gray	DG-LMBKK2.5	
Space compensation plate: used to offset interlayer misalignment when placed adjacent to a normal terminal: thickness 2.5mm	DP-LMBKK2.5	
Insertion bridge poles: 2 poles 10 poles	EB2-5; EB3-5; EB10-5	
With insulation pads bridge pieces: 10 poles, divisible, 10 screws, in order to form a jumper that skips some of the terminals, it needs to be padded	FBI10-5	
End damp: suitable for mounting rails of type or for supporting double deck	E/LUK	



LUK 5-HESI

6.3A 800V
Size: T8.2xH46.2xW72.6mm

Rigid wire: 0.2-4mm²
Flexible wire: 0.2-4mm²
With mark bar: ZB8

With or without indicator light

* The current is determined by the fuse

* The voltage is determined by the indicator light

IEC 60947-7-1



Parameters

Consumed current with indicator: suitable for C or L type guide rails, for fuse 5x20,5x25,6.3x32mm, indicators are optional	-
Consumed current with indicator: 15-24V AC/DC, 3.5-7.5mA	-
Consumed current with indicator: 110-250V AC/DC, 1.5-3.5mA AC, 0.2-0.8mA DC	-
Consumed current with indicator: 15-24V AC/DC, 3.5-7.5mA	LUK5-HESILED 24
Consumed current with indicator: 110-250V AC/DC, 1.5-3.5mA AC, 0.2-0.8mA DC	LUK5-HESILED 250
Fixed bridge: terminal center short connection, 10poles, divisible, 10screws, with insulating sleeve	-
Insertion bridge poles: 2poles 3poles 10poles	EB2-8; EB3-8; EB10-8



LUK 10-DREHSI

10A 800V
Size: T12.3xH55xW61.5mm

Rigid wire: 0.5-16mm²
Flexible wire: 0.5-16mm²
With mark bar: ZB8

With or without indicator light

* The current is determined by the fuse

* The voltage is determined by the indicator light

IEC 60947-7-1



Parameters

Consumed current with indicator: suitable for C or L type guide rails, for fuse 5x20,5x25,6.3x32mm, indicators are optional	LUK10-DREHSI 5x20
Consumed current with indicator: 15-24V AC/DC, 3.5-7.5mA	LUK10-DREHSILED 24 5x20
Consumed current with indicator: 110-250V AC/DC, 1.5-3.5mA AC, 0.2-0.8mA DC	LUK10-DREHSILED 250 5x20
Consumed current with indicator: 15-24V AC/DC, 3.5-7.5mA	-
Consumed current with indicator: 110-250V AC/DC, 1.5-3.5mA AC, 0.2-0.8mA DC	-
Fixed bridge: terminal center short connection, 10poles, divisible, 10screws, with insulating sleeve	FBI10-12
Insertion bridge poles: 2poles 3poles 10poles	EB2-12; EB3-12; EB10-12



LUK 5-MTK-P/P

16A 800V



Series knife disconnect terminal block

Size: T6.2xH62xW51.6mm

Rigid wire: 0.2-4mm²

Flexible wire: 0.2-4mm²

With mark bar: ZB6

IEC 60947-7-1



Parameters

Side plug stub: fully insulated /2 bit; Fully insulated /3 bit; Separable, insulated back /10 bit
End plate: Gray

EB2-6; EB3-6; EB10-6



Closed shell, no need to install end plate



LUDK 4

32A 690V



LUDK series terminals

Size: T6.2xH45.5xW58.4mm

Rigid wire: 0.2-4mm²

Flexible wire: 0.2-2.5mm²

With mark bar: ZB6

IEC 60947-7-1



Parameters

End cover: grey
Fixed bridge: for cross connection at terminal center, 10 screws, screw head with insulate collar, 10 poles, divisible
Insulation bridge: insulated 2poles, insulated 3poles, divisible, back insulated 10 poles
Emd clamp: suitable for mounting rails of type C or L for supporting double deck

D-LUDK 4



FBI10-6



EB2-6; EB3-6; EB10-6



E/LUK



LURTK/S

57A 400V



LUK series universal terminal block

Size: T8.1xH50.9xW72.5mm

Rigid wire: 0.5-10mm²

Flexible wire: 0.5-6mm²

With mark bar: ZB8

IEC 60947-7-1



Parameters

Knife disconnect terminal: universal mounting clamp for DIN rail type C or L test socket available at both sides
End plate: Gray
Center type bridge: used to disconnect part of the short on both sides, 10, separable, with 10 screws
Insertion bridge: insulated 2poles, insulated 3poles, divisible, back insulated 10poles
Switching jumper: on both sides of the disconnect point, switching inward, with 2 screws

D-LURTK/S



FB10-LRTK/S



EB2-8; EB3-8; EB10-8



LUSB2-LRTK/S



LBK 4

41A 800V



Series quaternary universal terminal block

Size: T20.5xH23xW34mm

Rigid wire: 0.2-6mm²

Flexible wire: 0.2-4mm²

Installation method: Panel screws M3

IEC 60947-7-1





LKLM-A

Insert strip-sheet, with locator holes and lines
 Used for terminal strip markers KLM1, Lettering area size: 24x4mm
 Terminal strip marker: for strip marking
 Adjustable height, mount on DIN Rail E/UK-NS or E/NS/35N used marker pen B-STIFT or CMS system
 Marking for insert strip ES/KLM 2-GB, Lettering area size: 44x7mm
 Terminal strip marker: Same above, without insert strip marker ES/KLM 2-GB
 Packing units: 50



B1/B2 (GREY)

Terminal strip marker: for strip marking
 Mounting on DIN Rail  or , with insert strip marker
 Used B-STIFT or CMS system to mark the strip
 Lettering field size: 40x17mm
 Packing units: 10



E/LMK End Clamp



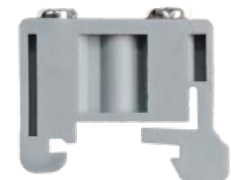

E/LMK 1

End clamp: mount on  Din Rail Ns15, T 6mm
 Mounting hole Ø3.2mm, material: KRILEN



E/LUK

End clamp: mount on DIN Rail  or 
 Fit for KLM strip marker or 1 piece of label No...8, T 9.5mm
 Material: KRILEN



E/AL-NS 35

End clamp: enhanced design, made of aluminum
 To support end 50-240mm² of the terminal strips, push mounting on  DIN Rail
 Clamped by 2 screws and, fit for 2 piece of label No...10, T 10mm



ZB/DEK



SPECIFICATION

Model No. Blank	Model NO.	Model NO.
ZB4-BLANK	ZB5 1-10	ZB6 1-10
ZB5-BLANK	ZB5 11-20	ZB6 11-20
ZB6-BLANK	ZB5 21-30	ZB6 21-30
ZB8-BLANK	ZB5 31-40	ZB6 31-40
ZB10-BLANK	ZB5 41-50	ZB6 41-50
DEK5-BLANK	ZB5 51-60	ZB6 51-60
DEK6-BLANK	ZB5 61-70	ZB6 61-70
	ZB5 71-80	ZB6 71-80
	ZB5 81-90	ZB6 81-90
	ZB5 91-100	ZB6 91-100
	ZB8 1-10	ZB10 1-10
	ZB8 11-20	ZB10 11-20
	ZB8 21-30	ZB10 21-30
	ZB8 31-40	ZB10 31-40
	ZB8 41-50	ZB10 41-50
	ZB8 51-60	ZB10 51-60
	ZB8 61-70	ZB10 61-70
	ZB8 71-80	ZB10 71-80
	ZB8 81-90	ZB10 81-90
	ZB8 91-100	ZB10 91-100

SPECIFICATION



Model NO.	Model NO.	Model NO.
ZB4 1-10	DEK5 1-10	DEK6 1-10
ZB4 11-20	DEK5 11-20	DEK6 11-20
ZB4 21-30	DEK5 21-30	DEK6 21-30
ZB4 31-40	DEK5 31-40	DEK6 31-40
ZB4 41-50	DEK5 41-50	DEK6 41-50
ZB4 51-60	DEK5 51-60	DEK6 51-60
ZB4 61-70	DEK5 61-70	DEK6 61-70
ZB4 71-80	DEK5 71-80	DEK6 71-80
ZB4 81-90	DEK5 81-90	DEK6 81-90
ZB4 91-99	DEK5 91-100	DEK6 91-100

LUSLKG Single push in and double-out plug-in terminal blocks

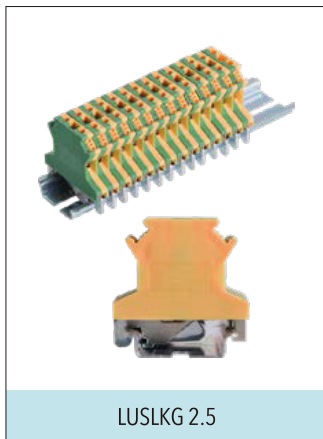

LUSLKG 2.5

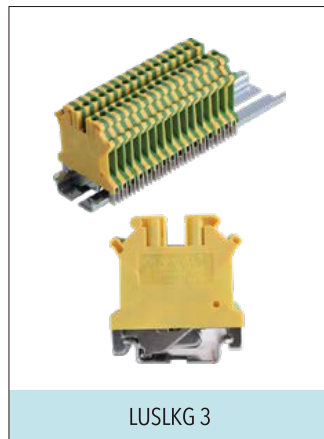

LUSLKG 3

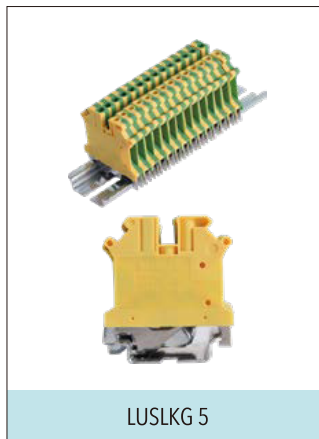

LUSLKG 5

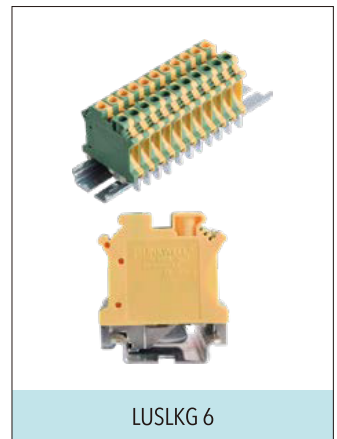

LUSLKG 6

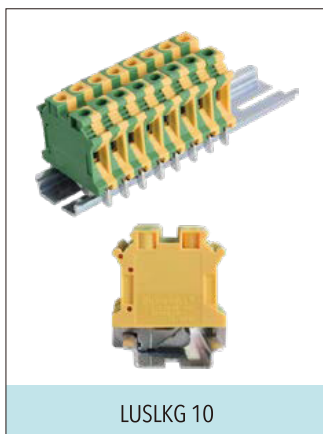

LUSLKG 10

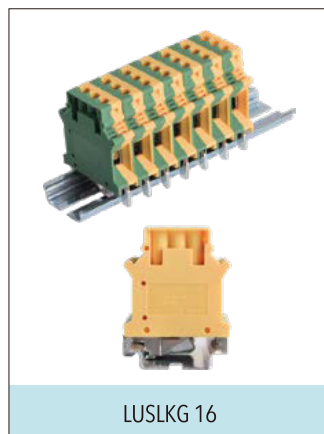

LUSLKG 16



LUSLKG 35



LUSLKG 50

SPECIFICATION

Model	Dimensions	Solid cross section	Stranded cross section	Zack strip	Approvals
	TxHxW (mm)	mm ²	mm ²		
LUSLKG 2.5	6.2x42x42.9	0.2-4	0.2-2.5	ZB6	CE & RoHs
LUSLKG 3	5.2x46x42.9	0.2-4	0.2-2.5	ZB5	CE & RoHs
LUSLKG 5	6.2x46x43.1	0.2-4	0.2-4	ZB6	CE & RoHs
LUSLKG 6	8.2x46x42.6	0.2-10	0.2-6	ZB6	CE & RoHs
LUSLKG 10	10.2x46x42.4	0.5-16	0.5-10	ZB10	CE & RoHs
LUSLKG 16	12.2x46x43.1	2.4-25	4-16	ZB10	CE & RoHs
LUSLKG 35	15.2x62x50.3	10-35	10-35	ZB10	CE & RoHs
LUSLKG 50	20.5x83.5x71	16-50	25-50	ZB10	CE & RoHs
LUKK5-PE	6.2x63x56.8	0.2-4	0.2-4	ZB6	CE & RoHs

EK

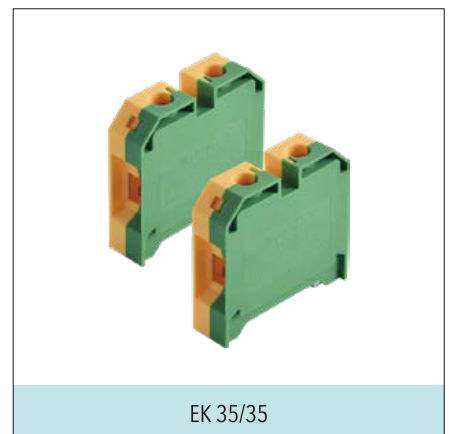
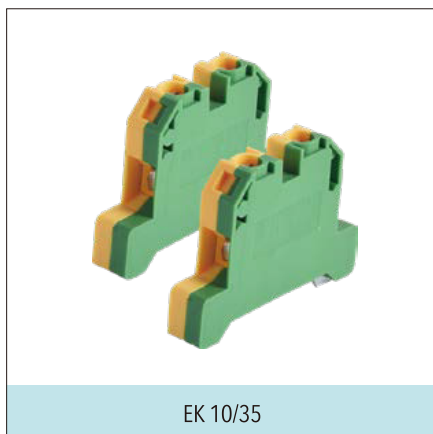
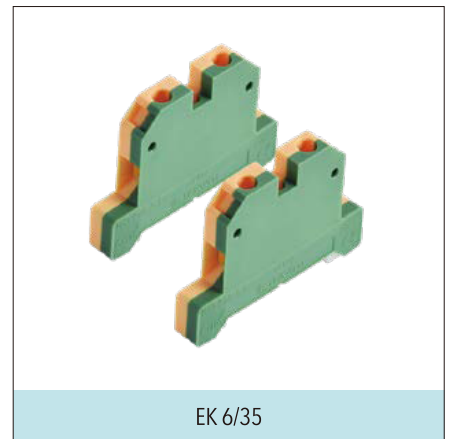
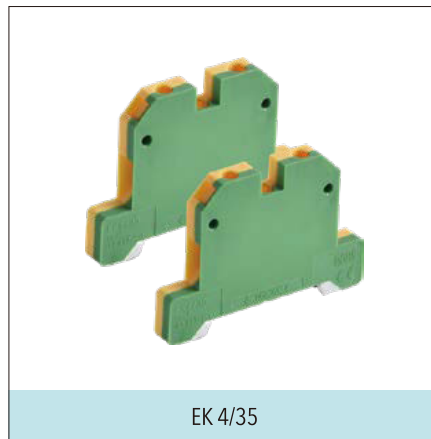
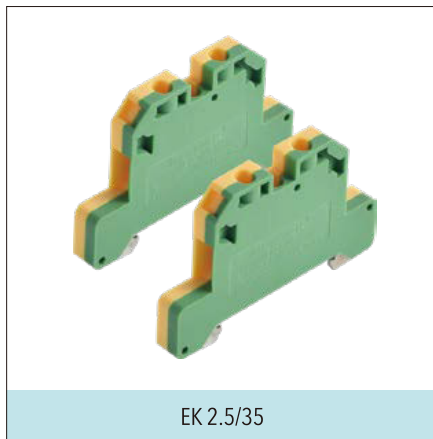

SPECIFICATION

Model	Dimensions	Stranded cross	Connection type	Approvals
	TxHxW (mm)	mm ²		
EK 2.5/35	6.6x36.5x56.5	0.2-2.5	screw connection	CE/RoHS/UL94V0
EK 4/35	6.6x40.3x57.4	0.2-4	screw connection	CE/RoHS/UL94V0
EK 6/35	8x40.4x57.1	0.2-6	screw connection	CE/RoHS/UL94V0
EK 10/35	10x40.3x56.8	0.5-10	screw connection	CE/RoHS/UL94V0
EK 16/35	12x46.5x57.2	0.5-16	screw connection	CE/RoHS/UL94V0
EK 35/35	16x56.6x58.6	10-35	screw connection	CE/RoHS/UL94V0

LSAK 2.5EN

24A 800V
Size: T6.1xH40.4xW40.9mm

Stranded cross: 0.2-2.5mm²
Connection type: Screw connection

IEC 60947-7-1

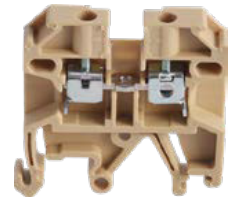

Parameters

End plate: thickness 1.5mm	AP2.5	
Centre type jumper bar: 10 potential, 2,3,4 potential	2.5EN, Q2poles, 3poles, 10poles	
End clamp	LEW35	
Continuous number of printing	DEK5/6(1...10)	

LSAK 4EN

32A 800V
Size: T6.5xH45.3xW40.6mm

Stranded cross: 0.2-4mm²
Connection type: Screw connection

IEC 60947-7-1



Parameters

End plate: thickness 1.5mm	AP4-10	
Centre type jumper bar: 10 potential, 2,3,4 potential	4EN, Q2poles, 3poles, 10poles	
End clamp	LEW35	
Continuous number of printing	DEK6(1...10)	

LSAK 6EN

41A 800V
Size: T7.9xH45xW39.9mm

Stranded cross: 0.2-6mm²
Connection type: Screw connection

IEC 60947-7-1



Parameters

End plate: thickness 1.5mm	AP4-10	
Centre type jumper bar: 10 potential, 2,3,4 potential	6EN, Q2poles, 3poles, 10poles	
End clamp	LEW35	
Continuous number of printing	DEK6(1...10)	

LSAK 10EN

57A 800V
Size: T10xH45.2xW40.5mm

Stranded cross: 0.5-10mm²
Connection type: Screw connection

IEC 60947-7-1

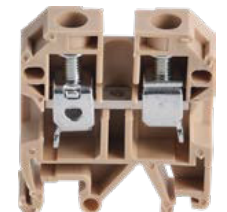

Parameters

End plate: thickness 1.5mm	AP4-10	
Centre type jumper bar: 10 potential, 2,3,4 potential	10EN, Q2poles, 3poles, 10poles	
End clamp	LEW35	
Continuous number of printing	DEK6(1...10)	

LSAK 16EN

76A 800V

Size: T12xH51.2xW50.3mm

Stranded cross: 0.5-16mm²

Connection type: Screw connection

IEC 60947-7-1



Parameters

End plate: thickness 1.5mm	AP16
Centre type jumper bar: 10 potential, 2,3,4 potential	16EN, Q2poles, 3poles, 10poles
End clamp	LEW35
Continuous number of printing	DEK5/6(1...10)

LSAK 35EN

125A 800V

Size: T18.2xH61.6xW58.5mm

Stranded cross: 10-35mm²

Connection type: Screw connection

IEC 60947-7-1



Parameters

End plate: thickness 1.5mm	AP35
Centre type jumper bar: 10 potential, 2,3,4 potential	35EN, Q2poles, 3poles, 10poles
End clamp	LEW35
Continuous number of printing	DEK6(1...10)

LASK1 EN

6.3A 500V

Size: T8.1xH39xW52.1mm

Stranded cross: 0.2-4mm²

Connection type: Screw connection

IEC 60947-7-1

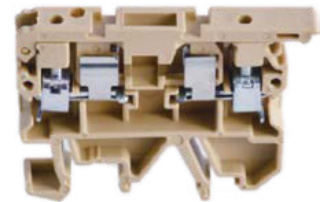

Parameters

End plate: thickness 1.5mm	AP-LASK1
-	-
End clamp	LEW35
Continuous number of printing	DEK6(1...10)

Solid-State Relay Module

- Input With LED Display
- NPN/PNP Compatible
- 4/8/16 Relay
- 35mm DIN Rail Installation



SPECIFICATION

Terminal Type	Screw terminal			Push-in terminal		
Model	LKMT04S-L	LKMT08S-L	LKMT16S-L	LKMT04M-L	LKMT08M-L	LKMT16M-L
Relay Digits	4	8	16	4	8	16
Dimension(mm)	48x85x38	70x85x38	130x85x38	48x85x39	70x85x39	130x85x39
Switch	MOSFET					
Output polarity	COM-					
Output Voltage	12~24VDC					
Peak Voltage	100V					
Short-time withstand current	10A					
Working Current	5A					
Output Protection	Built-in free-wheeling diode					
Input Voltage	12~24VDC					
Input polarity	COM+/-					
Isolation voltage resistance	3750V					
Operation temperture	-40°C~+70°C					

Model Designatio

SSR Module	Terminal Type	Terminal Type
	Screw	Push-in
LKMT 08	S	-L
Relay digits 04:04 digits 08:08 digits 16:16 digits	Module Base Color Standard:Green L:Black	

Input: 12~24VDC

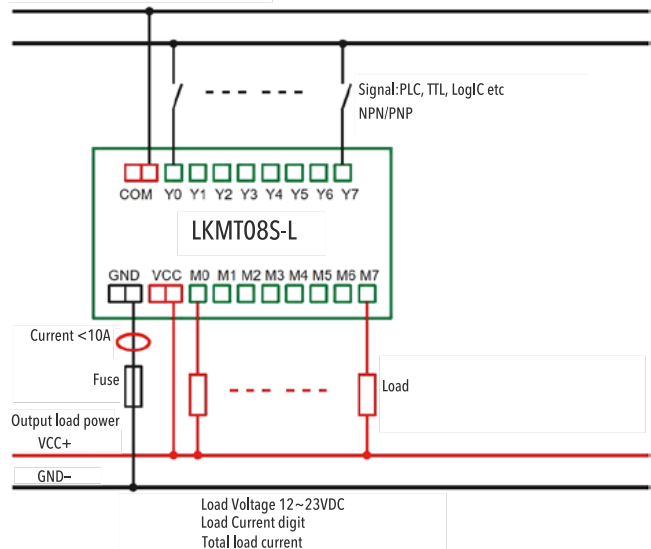

LAK/LAKG series TERMINAL BLOCK



Both LAK and LAKG interconnected end is designed for fixing the installed end. They are installed on the busbar 3x10mm

LAK: without insulation cap

LAKG: with insulation cap at different colours

There are also three different holders for different user, which including single, double and triple layers

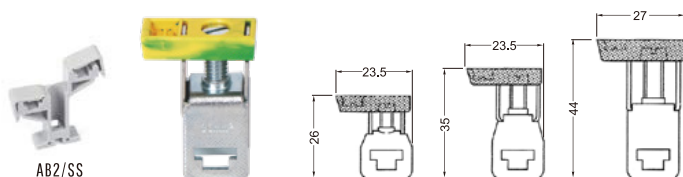
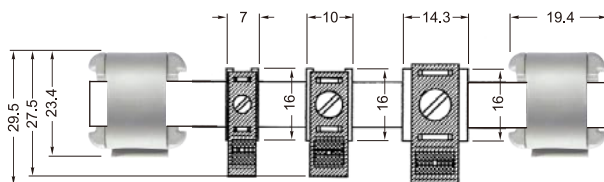

AB2/SS



SPECIFICATION

Model No.		
Ⓢ LAK 4 / LAKG 4 BU / LAKG 4 GNYE / LAKG 4 BK	N/PE interconnected end: 4mm ² No insulation cap/Insulation cap	Blue(For N) / Greenish yellow(For PE) / Black(For L1,L2,L3)
Ⓢ LAK 16 / LAKG 16 BU / LAKG 16 GNYE / LAKG 16 BK	N/PE interconnected end: 16mm ² No insulation cap/Insulation cap	Blue(For N) / Greenish yellow(For PE) / Black(For L1,L2,L3)
Ⓢ LAK 35 / LAKG 35 BU / LAKG 35 GNYE / LAKG 35 BK	N/PE interconnected end: 35mm ² No insulation cap/Insulation cap	Blue(For N) / Greenish yellow(For PE) / Black(For L1,L2,L3)
NLS-CU 3/10	(1)Copper busbar: 3×10mm, 1 meter long, tin plated, rated current 140A.	
AB/SS	(2)Single holder: using for busbar 3×10mm.	
AB/2SS	(3)Double-layer holder: using for busbar 3×10mm.	

*Pay attention to the current loading capacity of busbar.



Connection data	Solid wire (mm ²)	Multiple wire (mm ²)	AWG	I(A)
L(AKG) 4	0.5-4	0.5-4	20-12	32*
L(AKG) 16	1.5-16	1.5-16	16-6	76*
L(AKG) 35	1.5-35	1.5-25	16-2	125*

In switchgear and control equipment, it is sometimes necessary to connect the neutral and ground wires to a single busbar. This can be done using a busbar on which multiple wires are connected in a compact manner (up to 70 wires can be connected on a busbar one meter long). The conductor may be connected to the busbar by the press frame or the shrapnel, and the busbar may be pressed to the busbar support by the press plate or screw. The ZB and the 10 x 3mm or 6 x 6mm busbar can be used ideally as a junction between the neutral line and the ground line with the busbar frame.

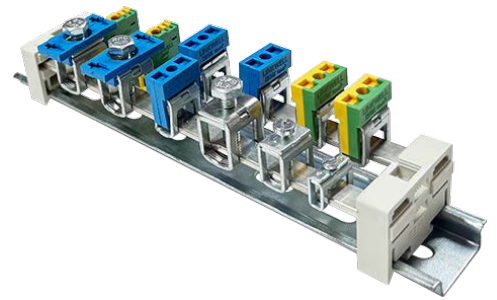

PMR 117

Fixed support



Materials: PA66-UL94-V0

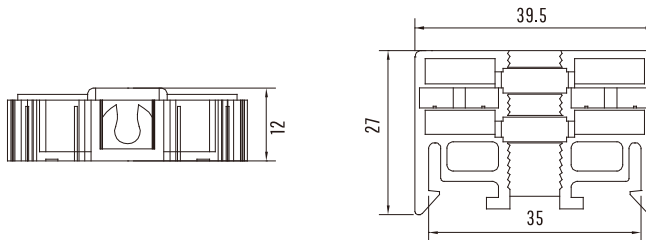

ZB 4

Busbar 10x3mm

Single hard wire: 0.5...6.0mm²
 Flexible conductor: 0.5...4.0mm²
 Screw: M3
 Wire stripping length: 16mm



SPECIFICATION

Model	Dimensions				Quantity
	a	thickness	c	h1	
ZB 4 (No insulating cover)	11.7	5.6	16.0	10.0	50

ZB16

Busbar 10x3mm

Single hard wire: 2.5...16mm²
 Flexible conductor: 2.5...16mm²
 Multiple hard wire: 16...25mm²
 Screw: M4
 Wire stripping length: 16mm



SPECIFICATION

Model	Dimensions				Quantity
	a	thickness	c	h1	
ZB 16 (No insulating cover)	17.0	10.0	16.0	17.0	50

ZB35

Busbar 10x3mm

Flexible conductor: 16...35mm²

Multiple hard wire: 16...50mm²

Screw: M6

Wire stripping length: 19mm



Model	Dimensions				Quantity
	a	thickness	c	h1	
ZB 35(No insulation cover)	21.0	14.4	18.4	20.5	20

ZB4K

Busbar 10x3mm



Single hard wire: 0.5...6.0mm²

Flexible conductor: 0.5...4.0mm²

Screw: M3

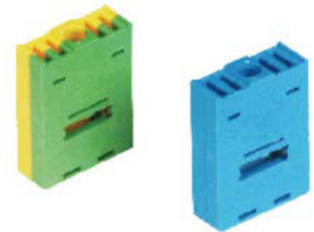
Wire stripping length: 16mm



Model	Dimensions				Quantity
	a2	thickness	d	h2	
ZB 4K GN/GE 	18.5	6.0	19.0	13.0	50
ZB 4K BL 	18.5	6.0	19.0	13.0	50

ZB16K

Busbar 10x3mm

Single hard wire: 2.5...16mm²



Flexible conductor: 2.5...16mm²

Multiple hard wire: 16...25mm²

Screw: M4

Wire stripping length: 16mm



Model	Dimensions				Quantity
	a	thickness	d	h1	
ZB 16K GN/GE 	24.0	10.0	19.2	20.0	50
ZB 16K BL 	24.0	10.0	19.2	20.0	50

ZB35K

Busbar 10x3mm



Flexible conductor: 16...35mm²

Multiple hard wire: 16...50mm²

Screw: M6

Wire stripping length: 19mm



Model	Dimensions				Quantity
	a	thickness	d	h1	
ZB 35K GN/GE 	24.0	10.0	19.2	20.0	50
ZB 35K BL 	24.0	10.0	19.2	20.0	50

SV Bus-bar Holder

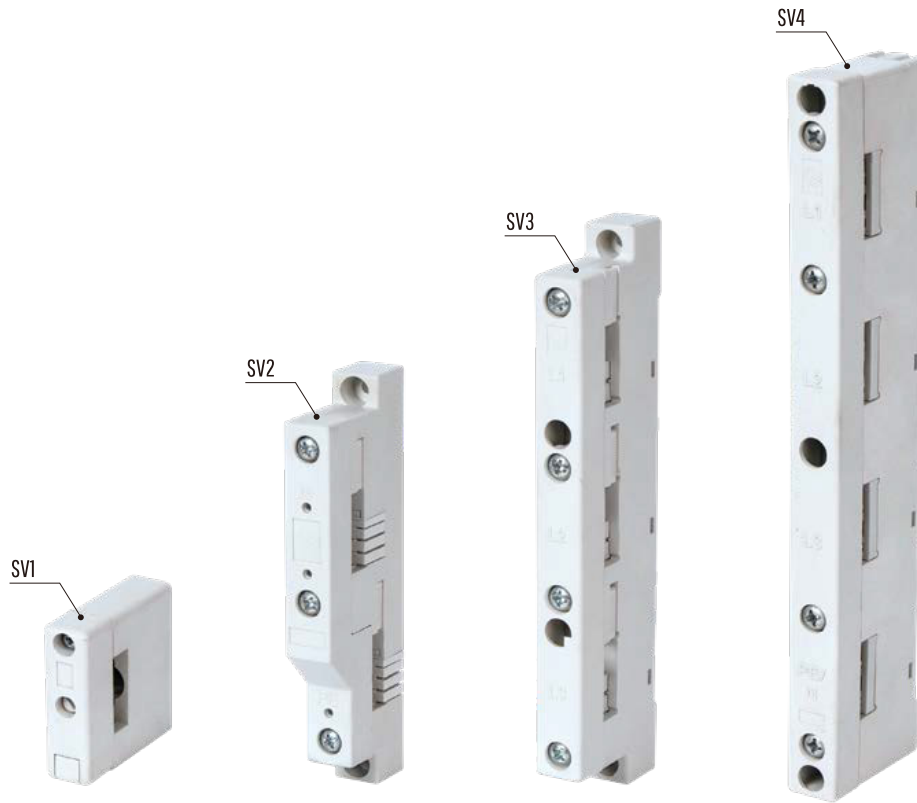

Rated working voltage up to 1000 volt,50/60 Hz. according to VDE 0660

Model	Rated current up to	Number of poles	Centre distance of bus stand	Suitable for Busbar size	Tightening turning moment		Per package
					Fixed screw	Fixed the cover	
SV1	800	1	-	30X10mm	5-8Nm	1-3Nm	2
SV2	800	2	60mm	30X10mm,30X5mm,25x10mm,25x5mm,20x10mm,20x5mm,15x10mm,15x5mm,12x10mm,12x5mm	3-5Nm	1-3Nm	2
SV3	800	2	60mm	30X10mm,30X5mm,25x10mm,25x5mm,20x10mm,20x5mm,15x10mm,15x5mm	3-5Nm	1-3Nm	2
SV4	800	4	60mm	30X10mm,30X5mm,25x10mm,25x5mm,20x10mm,20x5mm,15x10mm,15x5mm	3-5Nm	1-3Nm	2

Copper Busbar

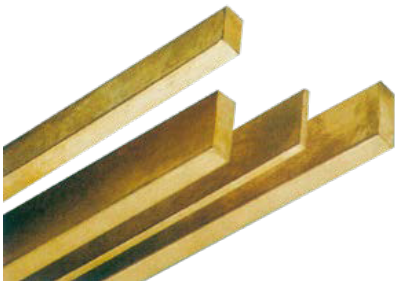

Model	Cu221	Cu222	Cu223	Cu224	Cu225
Specifications(mm)	30×5	25×5	20×10	20×5	30×10
Rated current(A)	447	384	497	319	800

1.Up to 2 meters copper plating. 2.Length optional electroless copper

Flexible Insulated Busbar



Technical parameters of conductors

Copper strips ($\geq 99.9\% \text{Cu}$)
Electrical conductivity: $\geq 55 \text{Sm/mm}^2$
Vickers hardness: $< 50 \text{HV}$

Tensile Strength: $\geq 200 \text{MPa}$
Extensibility: $\geq 30\%$

Technical data of flexible insulated busbars

Operating temperature: $-30 \sim +105^\circ \text{C}$
Flame retardant: self-extinguishing
Operating voltage: 750V

Compressive strength: 15min/50HZ
earth: $\geq 15 \text{kV}$
flexible insulated busbars: $\geq 30 \text{kV}$

Technical data of insulation

Material: PVC
Colour: black
Thickness: 1.8-2.1mm
Shore hardness: A70-80

Electrical strength: $\geq 23 \text{kV/mm}$
Oxygen index: 30%
Elasticity:
 $\geq 180\%$ after 7-day aging-test with 135°C
Tensile strength: $\geq 20 \text{MPa}$

SPECIFICATION

Dimensions and Qty (mmxmmx of strips)	Cross section (mm ²)	Ampacity (A)			Dimensions and Qty (mmxmmx of strips)	Cross section (mm ²)	Ampacity (A)		
		\triangle T=20K (3)	\triangle T=40K (4)	\triangle T=50K (5)			\triangle T=20K (3)	\triangle T=40K (4)	\triangle T=50K (5)
15.5 x 0.8 x 2	24.8	125	175	200	40 x 1 x 2	80	240	330	380
15.5 x 0.8 x 3	37.2	160	210	240	40 x 1 x 3	120	330	480	540
15.5 x 0.8 x 4	49.6	195	265	295	40 x 1 x 4	160	400	560	630
15.5 x 0.8 x 6	74.4	225	320	360	40 x 1 x 5	200	450	630	710
15.5 x 0.8 x 8	99.2	265	380	430	40 x 1 x 6	240	480	680	750
15.5 x 0.8 x 10	124	300	420	480	40 x 1 x 8	320	600	830	920
20 x 1 x 2	40	170	240	270	40 x 1 x 10	400	670	920	1030
20 x 1 x 3	60	230	320	360	50 x 1 x 3	150	400	570	650
20 x 1 x 4	80	270	380	440	50 x 1 x 4	200	490	700	790
20 x 1 x 5	100	300	430	490	50 x 1 x 5	250	540	780	880
20 x 1 x 6	120	330	470	530	50 x 1 x 6	300	590	840	950
20 x 1 x 8	160	400	560	620	50 x 1 x 8	400	680	1000	1130
20 x 1 x 10	200	420	580	650	50 x 1 x 10	500	750	1100	1300
24 x 1 x 2	48	200	280	320	63 x 1 x 5	315	650	900	1000
24 x 1 x 3	72	250	360	410	63 x 1 x 6	378	690	980	1100
24 x 1 x 4	96	280	410	460	63 x 1 x 8	504	840	1200	1350
24 x 1 x 5	120	330	470	530	63 x 1 x 10	630	920	1300	1450
24 x 1 x 6	144	360	510	570	80 x 1 x 5	400	700	1100	1230
24 x 1 x 8	192	420	590	670	80 x 1 x 6	480	780	1210	1360
24 x 1 x 10	240	500	700	790	80 x 1 x 8	640	950	1400	1570
32 x 1 x 2	64	230	320	360	80 x 1 x 10	800	1090	1550	1730
32 x 1 x 3	96	280	410	460	100 x 1 x 5	500	860	1250	1400
32 x 1 x 4	128	320	460	520	100 x 1 x 6	600	950	1380	1530
32 x 1 x 5	160	390	550	610	100 x 1 x 8	800	1100	1580	1760
32 x 1 x 6	192	440	620	700	100 x 1 x 10	1000	1220	1710	1920
32 x 1 x 8	256	510	720	822	100 x 1 x 12	1200	1300	1800	2010
32 x 1 x 10	320	600	840	930					

Wire terminal block (Push-in)



Scope of use:

Use as busbar system for L, N or PE cables in switchgear, control equipment and as conductor connection terminal in instrument boxes for installation in busbar systems E-Cu or CUPONAL

Mode of action:

Fully insulated terminals for tool-free wire connection
Wire release via inline unlocking pin

Material:

Polyamide
Fire resistance meets UL 94-V0 standard

Advantage:

No maintenance required
Time-saving plug-in installation
Marking area embedded in terminal housing
Universal conductor

SPECIFICATION

Model	Busbar thickness (mm)	Solid wire (mm ²)	Stranded wire (mm ²)
LK0905	5	0.5-6	0.5-4
LK1305	5	1.5-16	1.5-16
LK0910	10	0.5-6	0.5-4
LK1310	10	1.5-16	1.5-16
LK0905PE	5	0.5-6	0.5-4
LK1305PE	5	1.5-16	1.5-16
LK0910PE	10	0.5-6	0.5-4
LK1310PE	10	1.5-16	1.5-16

SPECIFICATION

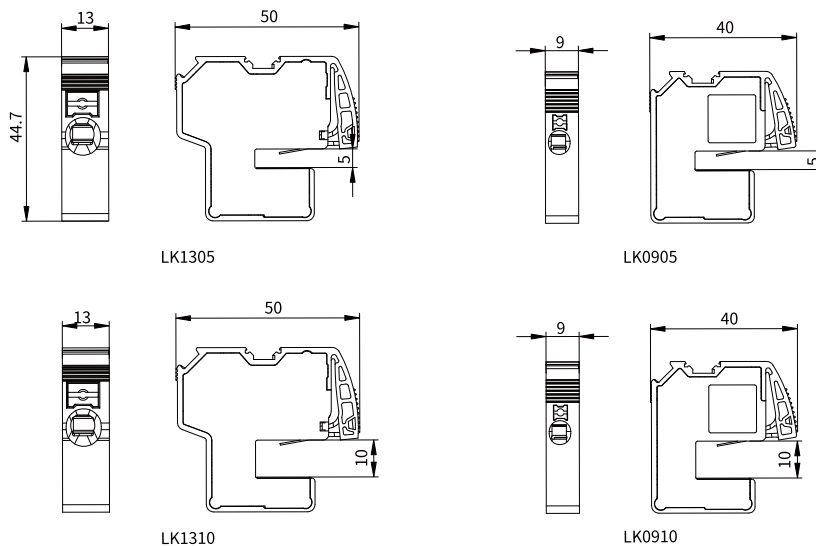

SV series Non-punched wire terminal block

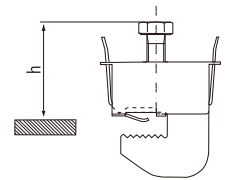

Model No.	H Minimum mm	H Maximum mm	Thickness of bus mm	Round lead wiring* mm	Piled copper busbar terminal space mm	Torque Nm	Per package pcs
SV201	17	23	4-5	1-4	-	2	50pcs
SV202	22	29	4-5	2.5-16	8 x 8	3	50pcs
SV203	26	39	4-5	16-50	10.5 x 11	6-8	50pcs
SV204	39	57	4-5	35-70	16.5 x 15	10-12	50pcs
SV205	44	66	4-5	70-185	22.5 x 20	12-15	50pcs
SV206	17	23	9-10	1-4	-	2	50pcs
SV207	22	29	9-10	2.5-16	8 x 8	3	50pcs
SV208	26	39	9-10	16-50	10.5 x 11	6-8	50pcs
SV209	39	57	9-10	35-70	16.5 x 15	10-12	50pcs
SV210	44	66	9-10	70-185	22.5 x 20	12-15	50pcs

LK series Busbar terminal



Model No.	For busbars	Connection min.-max.	Terminal space (W/H mm)	For use up to max.	Pack size	Weight kg/100u.	Part No.
LK401	5mm flat busbars	1.5-16	7.5x7.5	180A	100	2.1	01 284
LK402		4-35	10.5x11	270A	50	4.6	01 285
LK403		16-70	14x14	400A	25	7.1	01 287
LK404		16-120	17x15	440A	25	10.6	01 068
LK405	10mm flat busbars	1.5-16	7.5x7.5	180A	100	2.3	01 289
LK406		4-35	10.5x11	270A	50	4.7	01 290
LK407	10mm flat busbars double-T and triple-T section	16-70	14x14	400A	25	7.5	01 292
LK408		16-120	17x15	440A	25	10.9	01 203

SM25

Tensile strength(LBS): 500
Torgue strength(LBS): 6
Voltage withstand(KV): 6
screw(mm): 6
weight(G): 28

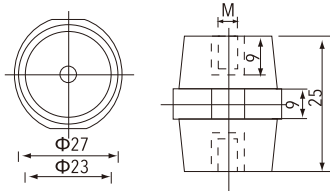

SM30

Tensile strength(LBS): 550
Torgue strength(LBS): 8
Voltage withstand(KV): 8
screw(mm): 8
weight(G): 44

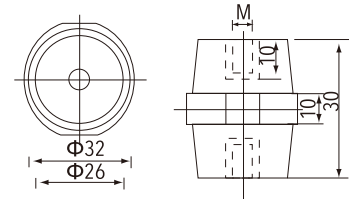

SM35

Tensile strength(LBS): 800
Torgue strength(LBS): 10
Voltage withstand(KV): 10
screw(mm): 8
weight(G): 50

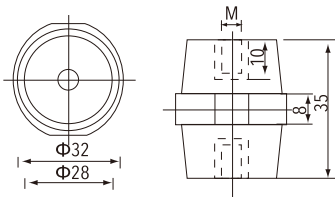

SM40

Tensile strength(LBS): 650
Torgue strength(LBS): 10
Voltage withstand(KV): 12
screw(mm): 8
weight(G): 86

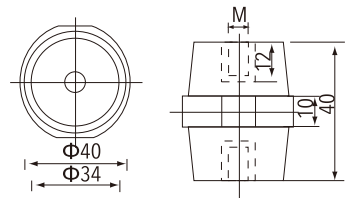

SM45

Tensile strength(LBS): 100
Torgue strength(LBS): 20
Voltage withstand(KV): 15
screw(mm): 10
weight(G): 70

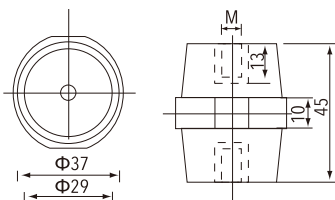

SM51

Tensile strength(LBS): 1000
Torgue strength(LBS): 20
Voltage withstand(KV): 15
screw(mm): 8
weight(G): 83

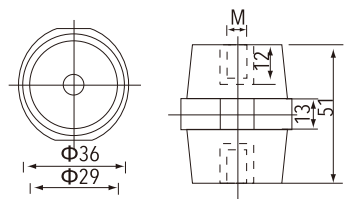

SM60

Tensile strength(LBS): 1500
Torgue strength(LBS): 40
Voltage withstand(KV): 25
screw(mm): 10
weight(G): 170

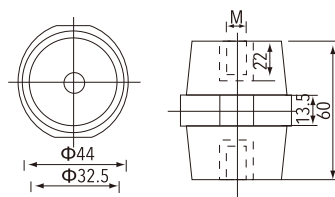

SM76

Tensile strength(LBS): 1500
Torgue strength(LBS): 40
Voltage withstand(KV): 25
screw(mm): 10
weight(G): 233

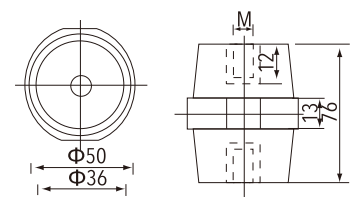

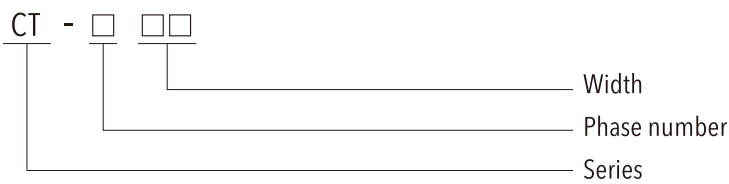
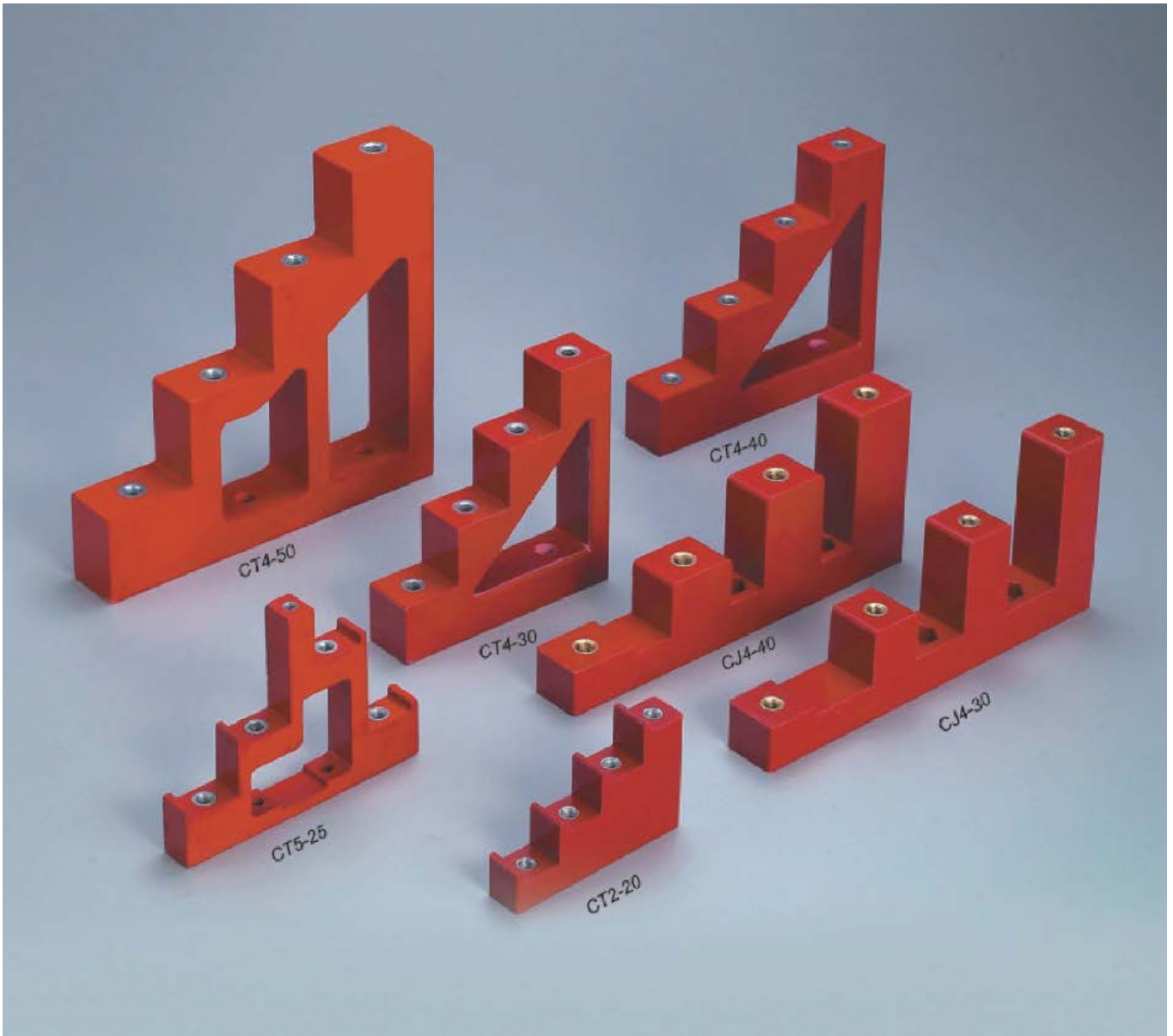

Parameters

Operating Temperature: -40~+140°C

Insert: Brass.Steel with Zn coating

Material: BMC(Bough Moulding Compound)

SMC(Sheet Moulding Compound)

Colour,Insert,material In capability accordance with customer needs

STEP INSULATORS

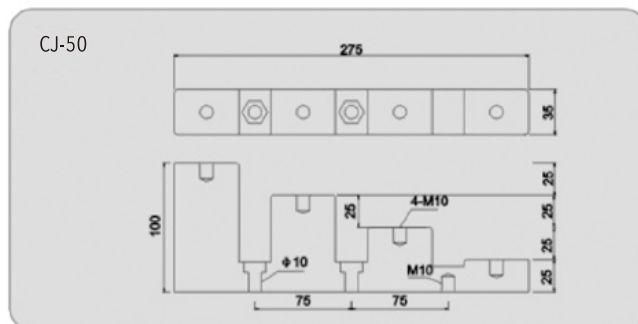
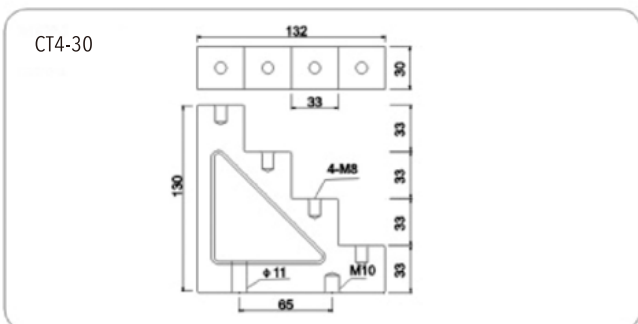
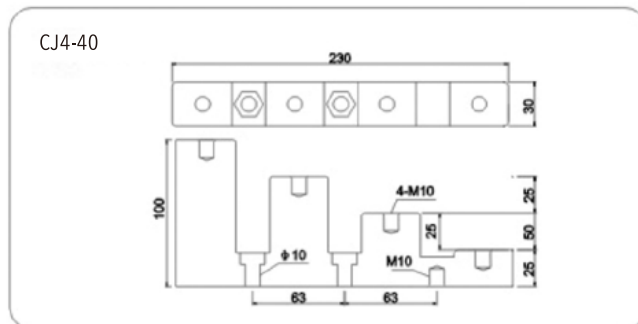
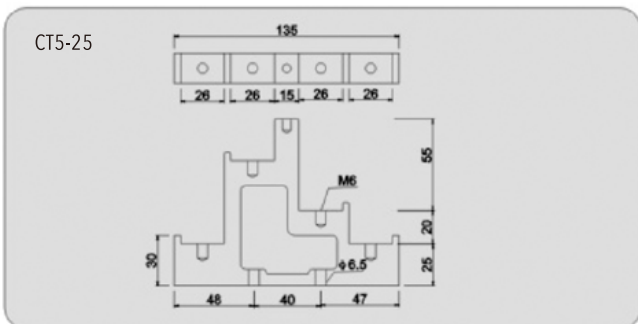
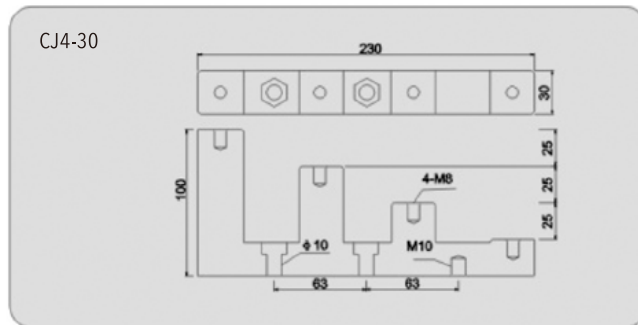
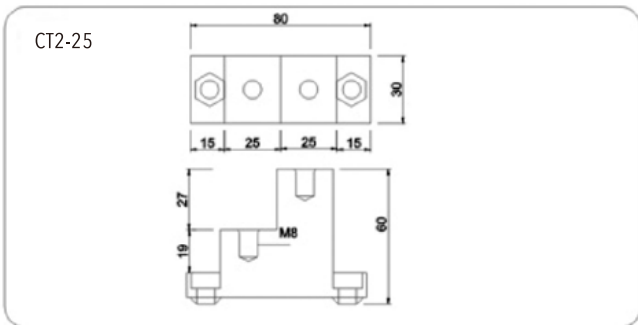
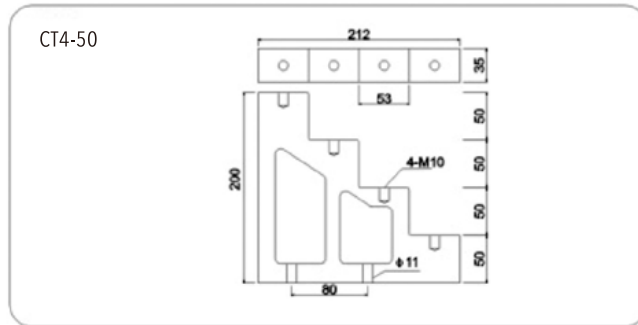
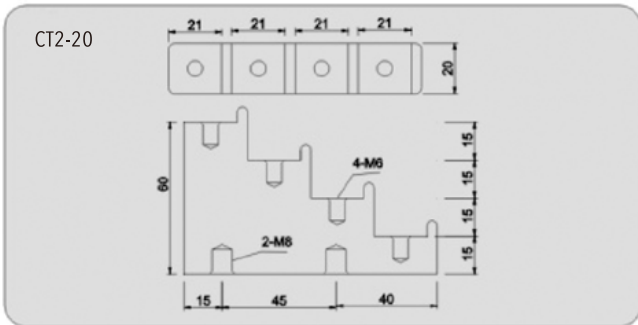
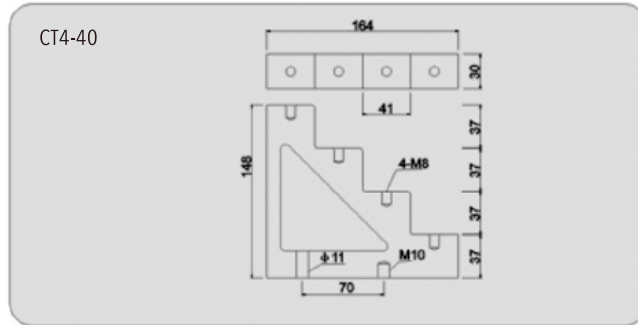
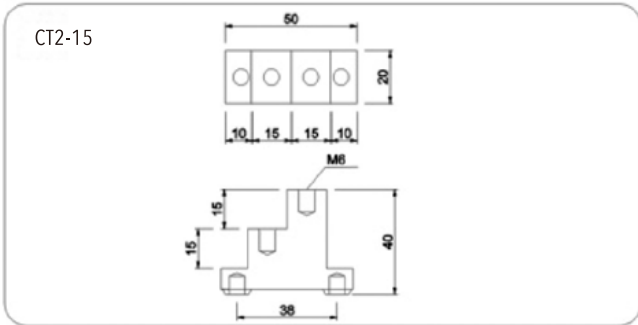



The RT18 series fuse is consisted of fuse-link and fuse-base. The fuse-link is made up of fuse-element with variable cross-section or just a wire.either of which is enclosed in a fuse-tube of high strength ceramics. The fuse-tube is filled with special quartzsands in a particular density, acting as an arcextinguish media. The fuse is of high breaking capacity, perfect current cutting-off characteristic and low power dissipation.

One desian. one series, suitable for being used by all power equipment manufacturers. RT series products have the lowest energy consumption design in the fuse industry, which is more energy-saving and eco-friendly.

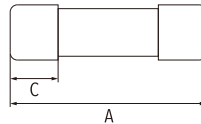

Model No.	Order Number	Rated Voltage	Rated Current	Dimension (mm)		
		V	A	A	ΦB	C
RT18-32	2C50A10G38F	AC500	2	38	10.3	10
	4C50A10G38F	AC500	4			
	6C50A10G38F	AC500	6			
	8C50A10G38F	AC500	8			
	10C50A10G38F	AC500	10			
	16C50A10G38F	AC500	16			
	20C50A10G38F	AC500	20			
	25C50A10G38F	AC500	25			
	32C40A10G38F	AC400	32			
RT18-63	10C50A14G51F	AC500	10	51	14.3	12
	16C50A14G51F	AC500	16			
	20C50A14G51F	AC500	20			
	25C50A14G51F	AC500	25			
	32C50A14G51F	AC500	32			
	36C50A14G51F	AC500	36			
	40C50A14G51F	AC500	40			
	50C50A14G51F	AC500	50			
	63C40A14G51F	AC400	63			
RT18-125	20C50A22G58F	AC500	20	58	22.2	14
	25C50A22G58F	AC500	25			
	32C50A22G58F	AC500	32			
	36C50A22G58F	AC500	36			
	40C50A22G58F	AC500	40			
	50C50A22G58F	AC500	50			
	63C50A22G58F	AC500	63			
	80C50A22G58F	AC500	80			
	100C50A22G58F	AC500	100			
	125C40A22G58F	AC400	125			

RT18-32/32X

RT18-32,RT18-32x,
stands for Light Indicator
Can be modularized
to be 2P,3P,4P.

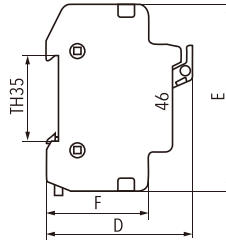
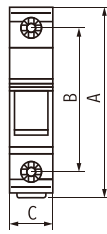

Parameters

Model No.	Order Number	Rated Voltage	Rated Current	Dimension (mm)					
				A	B	C	D	E	F
RT18-32	32K50A10F	AC500	32	80.5	62	17.5	62	78.5	43
RT18-32X	32XK50A10F	AC500	32						

RT18-63L/63LX

RT18-63L,RT63LX
Can be modularized to be 2P,3P,4P.
L: stands for Lockable
X: stands for Light indicator

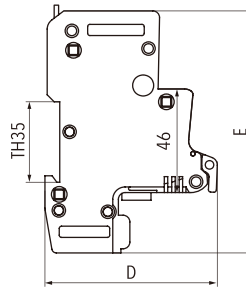
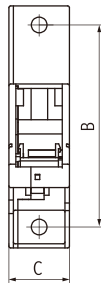

Parameters

Model No.	Order Number	Rated Voltage	Rated Current	Dimension (mm)					
				A	B	C	D	E	F
RT18-63L	63K50A14F	AC500	63	-	90	27	77	108	-
RT18-63LX	63XK50A14F	AC500	63						

RT18-125L/125LX

RT18-125L,RT125LX
Can be modularized to be 2P,3P,4P.
L: stands for Lockable
X: stands for Light indicator

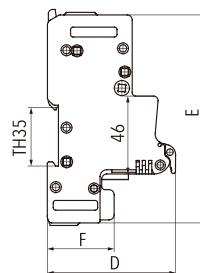

Parameters

Model No.	Order Number	Rated Voltage	Rated Current	Dimension (mm)					
				A	B	C	D	E	F
RT18-125L	125K50A22F	AC500	125	128	103	35.5	76	123	39.6
RT18-125LX	125XK50A22F	AC500	125						

Neutral conductor rail





Model No.	Terminal cross section	Dimension LxW (mm)	Rated Voltage V	Rated Current A
N7	7X16mm ²	54X23mm	400	63
PE7	7X16mm ²	54X23mm	400	63
U7	7X16mm ²	54X23mm	400	63

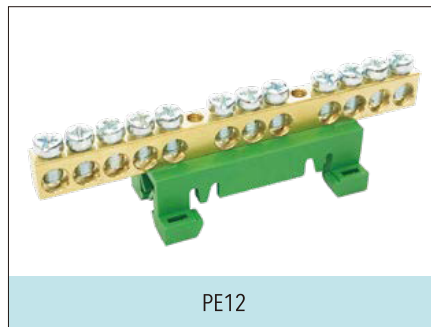
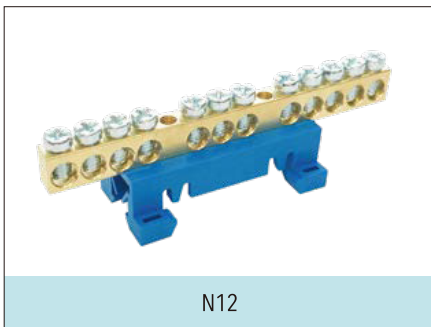

Model No.	Terminal cross section	Dimension LxW (mm)	Rated Voltage V	Rated Current A
N12	12X16mm ²	90X23mm	400	63
PE12	12X16mm ²	90X23mm	400	63
U12	12X16mm ²	90X23mm	400	63



Model No.	Terminal cross section	Dimension LxW (mm)	Rated Voltage V	Rated Current A
N15	15X16mm ²	110X23mm	400	63
PE15	15X16mm ²	110X23mm	400	63
U15	15X16mm ²	110X23mm	400	63

- Suitable for Cu cables: 2.5-16mm²
- Available in black, brown, grey, blue (N) and yellow/green (PE)
- Touchproof, IP20
- Housing and cover in PA66, UL94-V0

- Certified according to EN/IEC 60947-7-1, EN/IEC60947-7-2, EN60998-1
- Mounting: DIN-rail
- Environmentally friendly materials
- Durable laser markings



LK 1607

Un- 63A In(Cu)- 1000V

Pole: 1P
Key Size: M5
Mounting: Rail

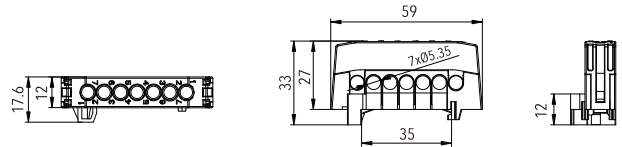

Parameters

Type	Color	Cu	Torque Cu	Weight
		mm ²	N-m	g
LK1607BK	Black ●	2.5-16	1.2	28.8
LK1607BL	Blue ●	2.5-16	1.2	28.8
LK1607BN	Brown ●	2.5-16	1.2	28.8
LK1607GY	Grey ●	2.5-16	1.2	28.8
LK1607YG	Yellow/Green ●●	2.5-16	1.2	28.8



LK 1612

Un- 63A In(Cu)- 1000V

Pole: 1P
Key Size: M5
Mounting: Rail

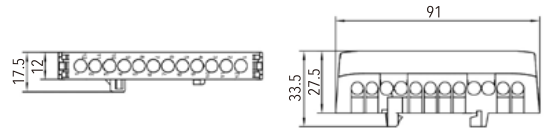

Parameters

Type	Color	Cu	Torque Cu	Weight
		mm ²	N-m	g
LK1612BK	Black ●	2.5-16	1.2	43.3
LK1612BL	Blue ●	2.5-16	1.2	43.3
LK1612BN	Brown ●	2.5-16	1.2	43.3
LK1612GY	Grey ●	2.5-16	1.2	43.3
LK1612YG	Yellow/Green ●●	2.5-16	1.2	43.3

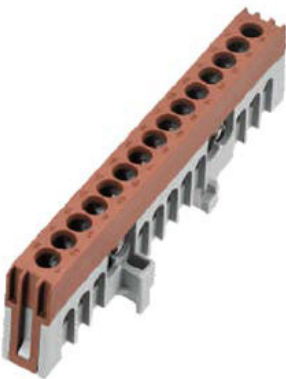

LK 1615

Un- 63A In(Cu)- 1000V

Pole: 1P
Key Size: M5
Mounting: Rail

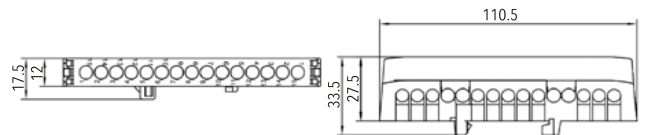

Parameters

Type	Color	Cu	Torque Cu	Weight
		mm ²	N-m	g
LK1615BK	Black ●	2.5-16	1.2	52.6
LK1615BL	Blue ●	2.5-16	1.2	52.6
LK1615BN	Brown ●	2.5-16	1.2	52.6
LK1615GY	Grey ●	2.5-16	1.2	52.6
LK1615YG	Yellow/Green ●●	2.5-16	1.2	52.6



LK032

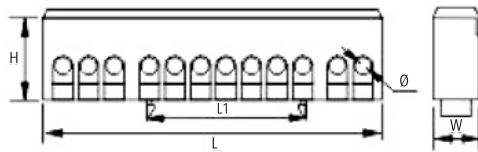

Item no.	Spec.	L1	L2	H	W	Ø	screw size	Plastic setting
	w x h-hole	mm						
LK 032-01	6x9-7	53.0	35.0	26.3	13.0	5.2	M5.0	PA
LK 032-02	6x9-12	88.0	35.0	26.3	13.0	5.2	M5.0	PA
LK 032-03	6x9-15	108.0	35.0	26.3	13.0	5.2	M5.0	PA

D-8X12

There are 8x12 copper rows in insulating crust

- D-8x12/12 Potential
- D-8x12/10 Potential
- D-8x12/8 Potential
- D-8x12/6 Potential
- D-8x12/4 Potential

G-8X12

G-8x12 copper rows in insulating crust with earthing in one end.

- G-8x12/12 Potential
- G-8x12/10 Potential
- G-8x12/8 Potential
- G-8x12/6 Potential
- G-8x12/4 Potential

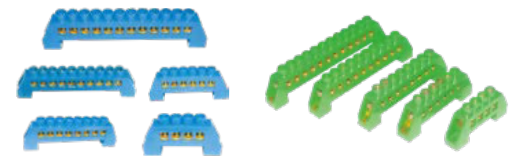

LK033

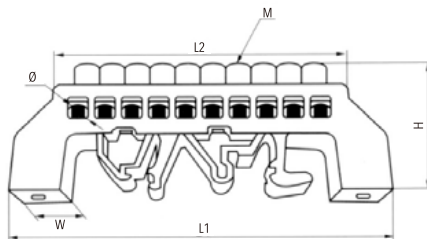

Item no.	Spec.	L1	L2	H	W	Φ	screw size	Plastic setting
	w x h-hole	mm						
LK 033-01	6x9-4	57.5	34	34.5	10.5	5.0	M4	PA
LK 033-02	6x9-6	57.7	46.7	34.5	10.5	5.0	M4	PA
LK 033-03	6x9-8	78.5	60	34.5	10.5	5.0	M4	PA
LK 033-04	6x9-10	89	72.8	34.5	10.5	5.0	M4	PA
LK 033-05	6x9-12	102	85.7	34.5	10.5	5.0	M4	PA
LK 033-06	8x12-4	77.5	40.6	38.6	12.6	7.0	M5	PA
LK 033-07	8x12-6	77.5	57.3	38.6	12.6	7.0	M5	PA
LK 033-08	8x12-8	94.3	74.4	38.6	12.6	7.0	M5	PA
LK 033-09	8x12-10	111.0	91	38.6	12.6	7.0	M5	PA
LK 033-10	8x12-12	128.4	108.6	38.6	12.6	7.0	M5	PA
LK 033-11	8x12-14	145.8	135.6	38.6	12.6	7.0	M5	PA

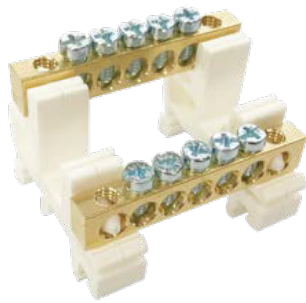

H10X16



TERMINAL HOLDER -H10x16 FOR 63A

Width: 50 mm

material holder: PA 66

free of halogen

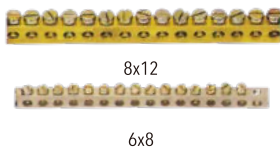
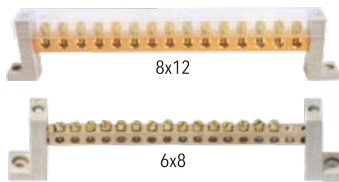

H8X12/6X8



Busbar plated or not for Imeter.

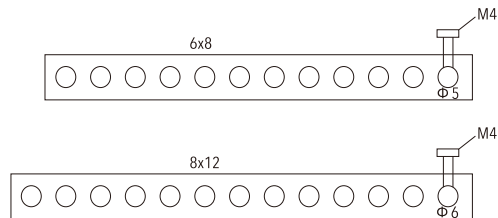

DRB



Double row brass terminal series

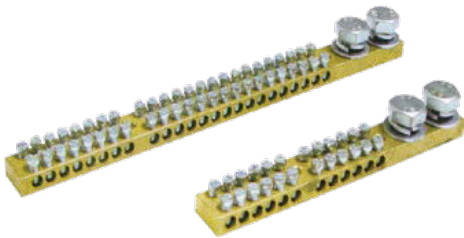

DRB-9x19/24

DRB-9x19/12

Model No.	Way	Brass specification (mm)	Rated current (A)	Dimension (mm)	Screw no.s	Installation hole Distance
DRB-9x19/6	6	9x19	180A	102x45x45	2 x M10/12 x M5	50 (M5)
DRB-9x19/12	12	9x19	180A	144x45x45	2 x M10/24 x M5	50 (M5)
DRB-9x19/18	18	9x19	180A	187x45x45	2 x M10/36 x M5	120 (M5)
DRB-9x19/24	24	9x19	180A	230x45x45	2 x M10/48 x M5	120 (M5)
DRB-9x19/36	36	9x19	180A	315x45x45	2 x M10/72 x M5	120 (M5)