

DC Oil Free Air Compressor

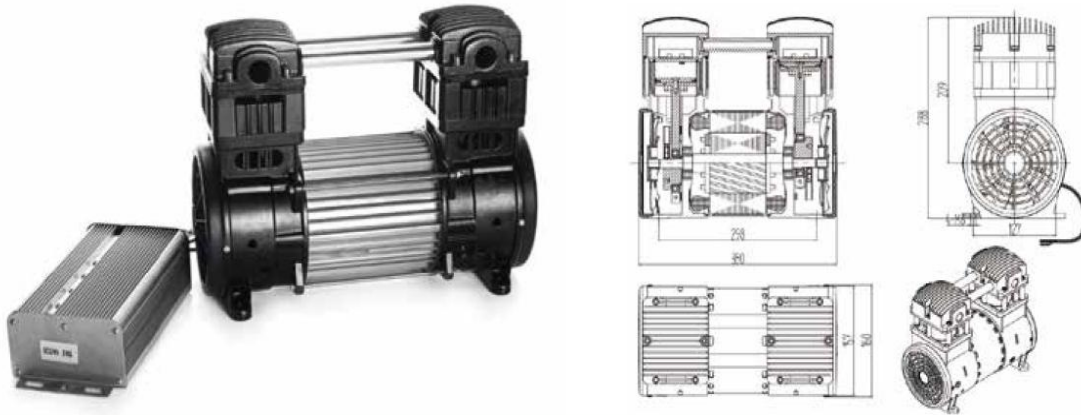

Technical Specification

| Model | HC1500D-120/8 | HC1500E-120/8 | HC1500F-120/8 |
|---------------------------------|--------------------|--------------------|--------------------|
| Voltage | DC24V | DC48V | DC144V |
| Current at rated pressure | 62.5 A | 31.2 A | 10.4 A |
| Power at rated pressure | ≤1500W | ≤1500W | ≤1500W |
| Air flow rate at rated pressure | 120 L/min @ 800Kpa | 120 L/min @ 800Kpa | 120 L/min @ 800Kpa |
| Dimension | 380*160*288 mm | 380*160*288 mm | 380*160*288 mm |
| Installation size | 127*298 mm(4xM8) | 127*298 mm(4xM8) | 127*298 mm(4xM8) |
| Rated speed | 1700rpm | 1700rpm | 1700rpm |
| Net weight | 12.6 kg | 12.6 kg | 12.6 kg |
| Noise | ≤68dB(A) | ≤68dB(A) | ≤68dB(A) |

Performance Chart - Flow VS. Pressure

