

AC Oil Free Air Compressor

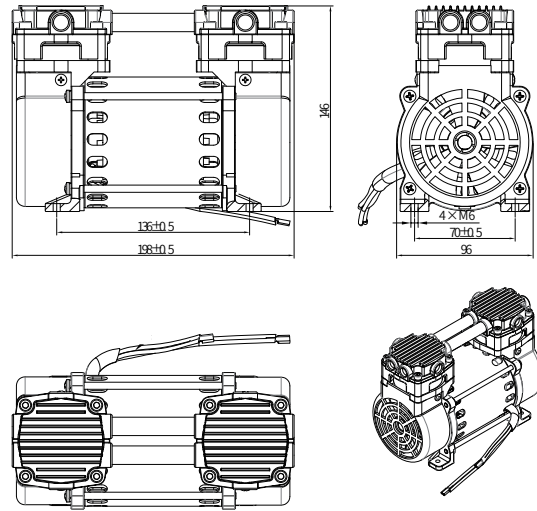

Technical Specification		
Model Number	HC100A-9/7	HC100B-10/7
Head configuration	Pressure parallel fow	Pressure parallel fow
Voltage	220V/50Hz/1	110V/60Hz/1
Power at rated pressure	≤190W	≤230W
Air flow rate at rated pressure	9L/min@700Kpa	10L/min@700Kpa
Speed at rated pressure	1400rpm	1700rpm
Dimension	198×96×146mm	198×96×146mm
Installation size	136×70mm	136×70mm
Net weight	4.3kg	4.3kg
Operating ambient air temperature	-5 to 40°C	-5 to 40°C
Thermal protection	145±5°C	145±5°C
Motor insulation class	F	F
Capacitor value	8μF	15μF

Performance Chart - Flow VS. Pressure

