

AC Oil Free Air Compressor

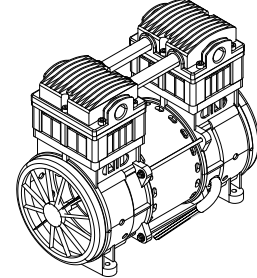

Technical Specification		
Model Number	HC1100A-100/8	HC1100B-100/8
Head configuration	Pressure parallel fow	Pressure parallel fow
Voltage	220V/50Hz/1	110V/60Hz/1
Power	≤1100W	≤1100W
Air flow rate	100L/min@800Kpa	100L/min@800Kpa
Speed at rated pressure	1400rpm	1700rpm
Dimension	330×167×278mm	330×167×278mm
Installation size	244×127mm	244×127mm
Net weight	17.2kg	17.2kg
Operating ambient air temperature	-5 to 40°C	-5 to 40°C
Thermal protection	145±5°C	145±5°C
Motor insulation class	F	F
Capacitor value	30μF	120μF

Performance Chart – Flow VS. Pressure

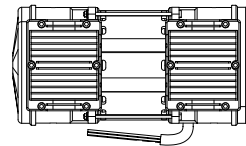
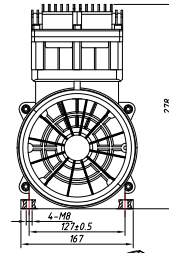
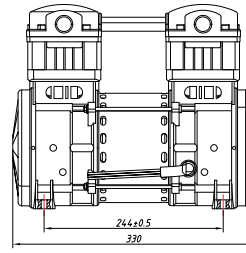
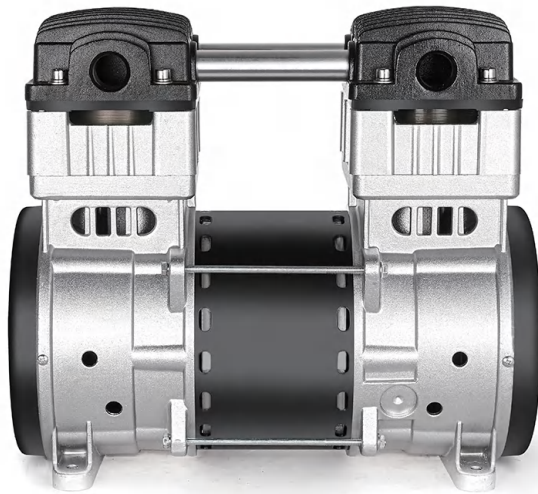