

# DC Oil Free Vacuum Pump

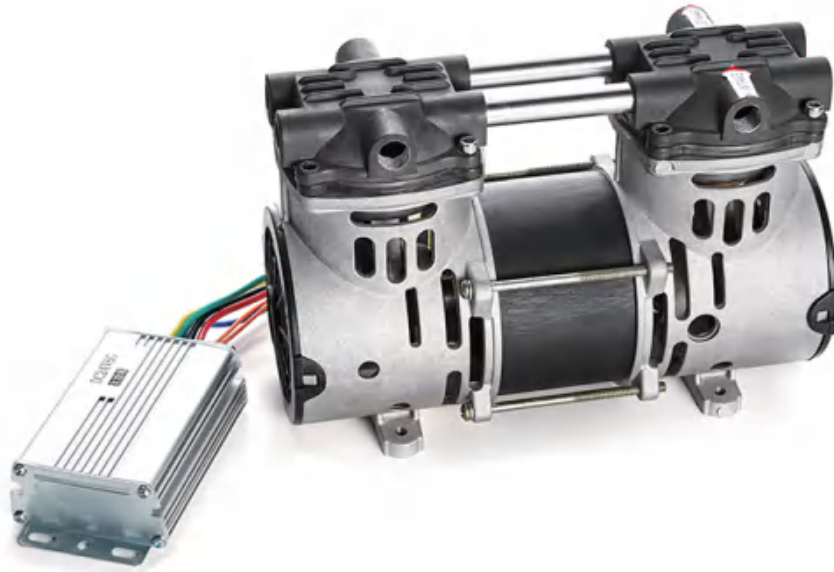

## Technical Specification

Model Number	HC280C	HC280D	HC280E
Voltage	DC12V	DC24V	DC48V
Noise	≤58dB(A)	≤58dB(A)	≤58dB(A)
Power at rated pressure	≤180W	≤180W	≤180W
Vacuum flow rate @ pressure (There's are two options, but you can only choose one)	90 L/min @ -92Kpa	90 L/min @ -92Kpa	90 L/min @ -92Kpa
	40 L/min @ -98Kpa	40 L/min @ -98Kpa	40 L/min @ -98Kpa
Speed at rated pressure	≤1700rpm	≤1700rpm	≤1700rpm
Dimension	242×104×165mm	242×104×165mm	242×104×165mm
Installation Size	147×83mm	147×83mm	147×83mm
Net Weight	4.9kg	4.9kg	4.9kg

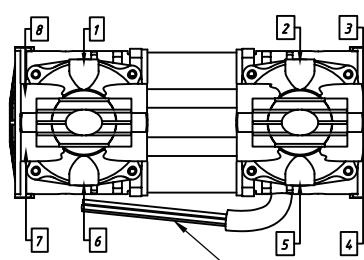
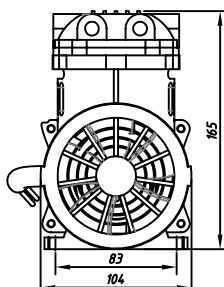
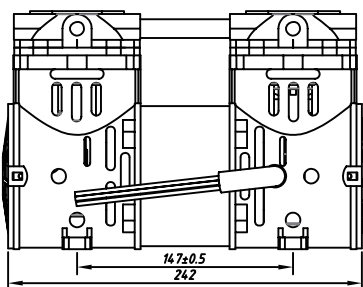

Yellow,White and Blue power cord:  
260±20mm (5.2mm Ø-type terminal)

