

AC Oil Free Air Compressor

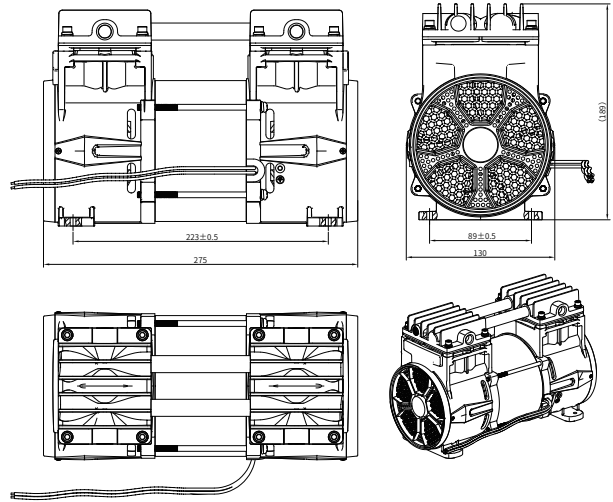

Technical Specification		
Model Number	HC550A-40/7	HC550B-45/7
Head configuration	Pressure parallel fow	Pressure parallel fow
Voltage	220V/50Hz/1	110V/60Hz/1
Power at rated pressure	≤480W	≤540W
Air flow rate	40L/min@700Kpa	45L/min@700Kpa
Speed at rated pressure	1400rpm	1700rpm
Dimension	275×130×189mm	275×130×189mm
Installation size	223×89mm	223×89mm
Net weight	8.5kg	8.5kg
Operating ambient air temperature	-5 to 40°C	-5 to 40°C
Thermal protection	145±5°C	145±5°C
Motor insulation class	F	F
Capacitor value	12.5μF	45μF

Performance Chart - Flow VS. Pressure

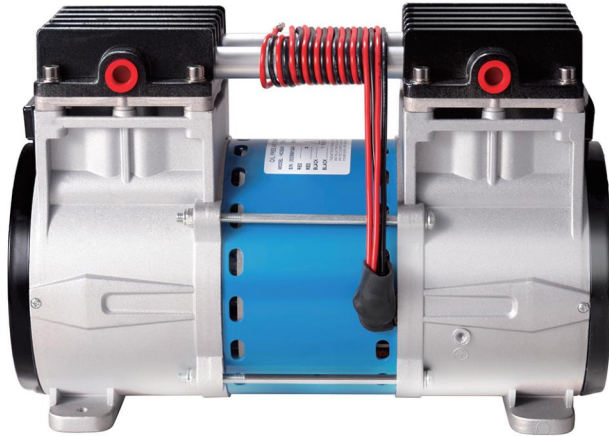