

DC Oil Free Air Compressor

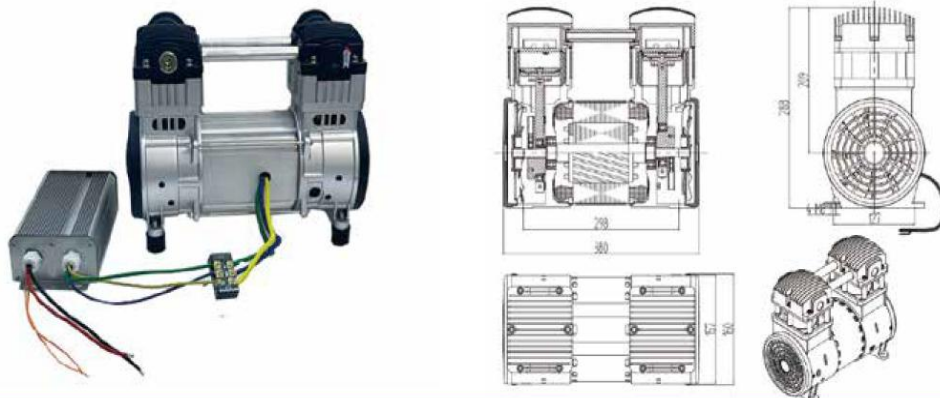

Technical Specification

Model	HC1100D-100/8	HC1100E-100/8	HC1100F-100/8
Voltage	DC24V	DC48V	DC144V
Current at rated pressure	45.8A	22.9A	7.6A
Power at rated pressure	≤1100W	≤1100W	≤1100W
Air flow rate at rated pressure	100 L/min @ 800Kpa	100 L/min @ 800Kpa	100 L/min @ 800Kpa
Dimension	380 *160*288 mm	380 *160*288 mm	380 *160*288 mm
Installation size	127*298 mm(4xM8)	127*298 mm(4xM8)	127*298 mm(4xM8)
Rated speed	1700rpm	1700rpm	1700rpm
Net weight	12.6 kg	12.6 kg	12.6 kg
Noise	≤68dB(A)	≤68dB(A)	≤68dB(A)

Performance Chart - Flow VS. Pressure

