

DC Oil Free Air Compressor

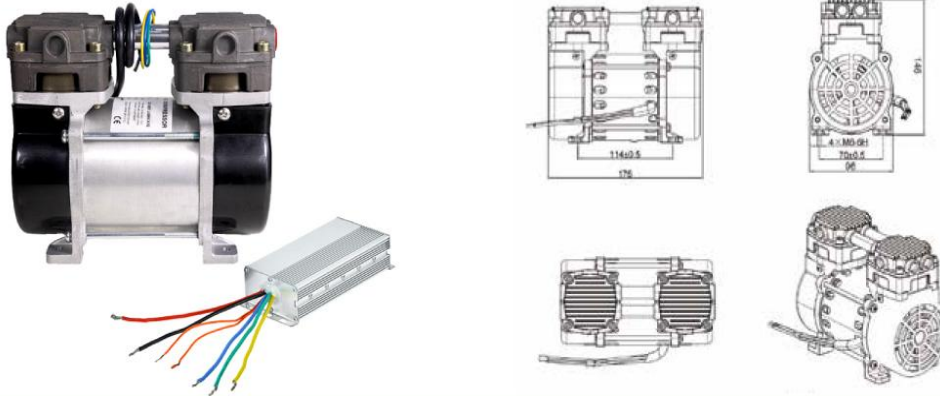

Technical Specification

Model	HC100C-9/7	HC100D-9/7	HC100E-9/7
Voltage	DC12V	DC24V	DC48V
Current at rated pressure	16.7 A	8.3 A	4.17 A
Power at rated pressure	≤200W	≤200W	≤200W
Air flow rate at rated pressure	9L/min @700Kpa	9L/min @700Kpa	9L/min @700Kpa
Dimension	176*96*146 mm	176*96*146 mm	176*96*146 mm
Installation size	70*114 mm(4xM6)	70*114 mm(4xM6)	70*114 mm(4xM6)
Rated speed	1700rpm	1700rpm	1700rpm
Net weight	2.45 kg	2.45 kg	2.45 kg

Performance Chart - Flow VS. Pressure

