

# AC Oil Free Air Compressor

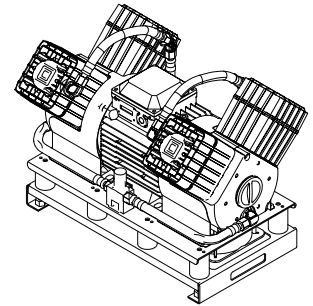
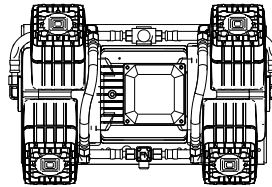
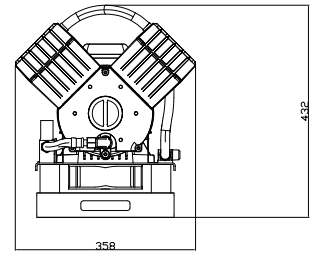
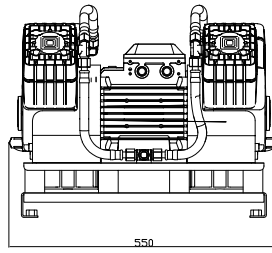

## Technical Specification

	HC50 4V-270/10	HC50 4V-315/10
<b>Model Number</b>	HC50 4V-270/10	HC50 4V-315/10
<b>Head configuration</b>	Pressure parallel fow	Pressure parallel fow
<b>Voltage</b>	380V/50Hz/3	380V/50Hz/3
<b>Power</b>	≤3100W	≤3600W
<b>Air flow rate</b>	270L/min@1000Kpa	315L/min@1000Kpa
<b>Speed at rated pressure</b>	1400rpm	1400rpm
<b>Dimension</b>	550×358×432mm	550×358×432mm
<b>Net weight</b>	52.5 kg	52.5 kg
<b>Motor insulation class</b>	F	F

Performance Chart - Flow VS. Pressure

