

# DC Oil Free Air Compressor

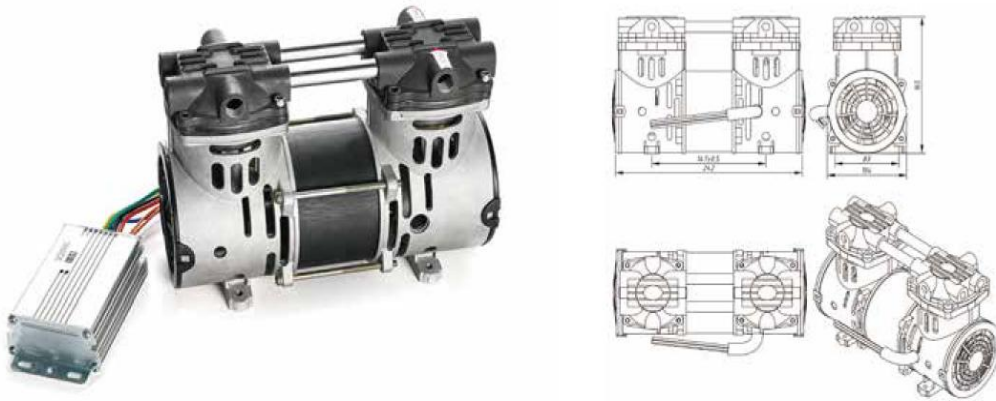

## Technical Specification

Model	HC280C-25/7	HC280D-25/7	HC280E-25/7
Voltage	DC12V	DC24V	DC48V
Current at rated pressure	30.8 A	15.4 A	7.7A
Power at rated pressure	≤370W	≤370W	≤370W
Air flow rate at rated pressure	25L/min @ 700Kpa	25L/min @ 700Kpa	25L/min @ 700Kpa
Dimension	242*104*165 mm	242*104*165 mm	242*104*165 mm
Installation size	83*147 mm(4xM6)	83*147 mm(4xM6)	83*147 mm(4xM6)
Rated speed	1700rpm	1700rpm	1700rpm
Net weight	6.0 kg	6.0 kg	6.0 kg
Noise	≤62dB(A)	≤62dB(A)	≤62dB(A)

## Performance Chart - Flow VS. Pressure

