

# DC Oil Free Air Compressor

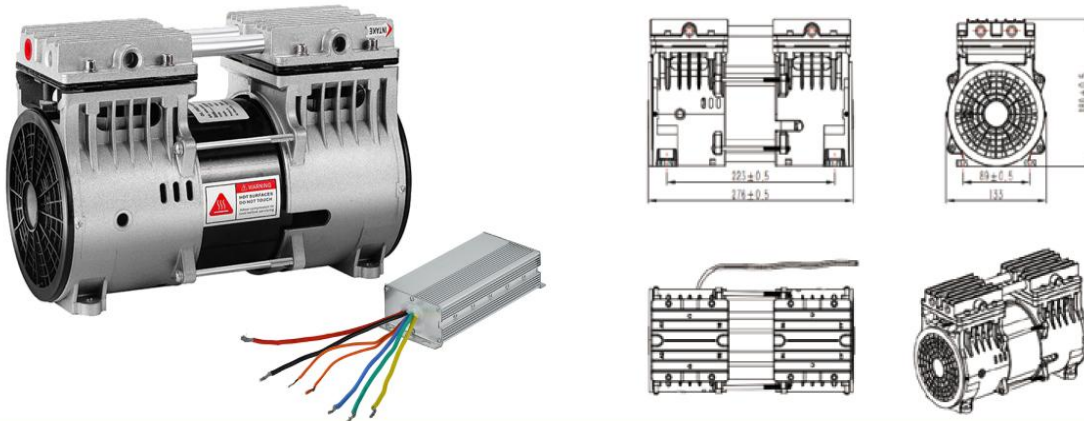

## Technical Specification

| Model                           | HC480C-45/7       | HC480D-45/7       | HC480E-45/7       |
|---------------------------------|-------------------|-------------------|-------------------|
| Voltage                         | DC12V             | DC24V             | DC48V             |
| Current at rated pressure       | 46.66 A           | 23.33 A           | 11.66 A           |
| Power at rated pressure         | ≤560W             | ≤560W             | ≤560W             |
| Air flow rate at rated pressure | 45 L/min @ 700Kpa | 45 L/min @ 700Kpa | 45 L/min @ 700Kpa |
| Dimension                       | 276*133*180 mm    | 276*133*180 mm    | 276*133*180 mm    |
| Installation size               | 89*223 mm(4xM6)   | 89*223 mm(4xM6)   | 89*223 mm(4xM6)   |
| Rated speed                     | 1700rpm           | 1700rpm           | 1700rpm           |
| Net weight                      | 7 kg              | 7 kg              | 7 kg              |
| Noise                           | ≤65dB(A)          | ≤65dB(A)          | ≤65dB(A)          |

## Performance Chart - Flow VS. Pressure

