

DC Oil Free Air Compressor

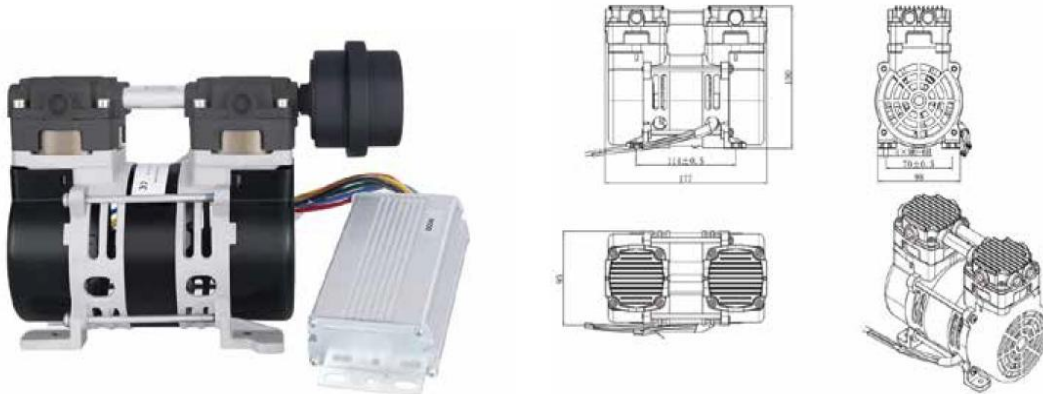

Technical Specification

Model	HC210C-11/7	HC210D-11/7	HC210E-11/7
Voltage	12V	24V	48V
Current at rated pressure	17.5A	8.75A	4.38A
Power at rated pressure	≤210W	≤210W	≤210W
Air flow rate at rated pressure	11 L/min @ 700Kpa	11 L/min @ 700Kpa	11 L/min @ 700Kpa
Dimension	177*98*150 mm	177*98*150 mm	177*98*150 mm
Installation size	70*114 mm(4xM6)	70*114 mm(4xM6)	70*114 mm(4xM6)
Rated speed	1700rpm	1700rpm	1700rpm
Net weight	3 kg	3 kg	3 kg
Noise	≤61dB(A)	≤61dB(A)	≤61dB(A)

Performance Chart - Flow VS. Pressure

