



Forever Medical

Hydraulic Funeral Equipment Adjustable Embalming Table

YJ-ET104 Hydraulic adjustable embalming table for morgue room .

Large load weight : 250 kg .

The **adjustable embalming table** is designed for dissection of cadaver and includes a recessed top with eliminates the need for a body tray . The downdraft system provides a safe environment , completely ventilating formalin vapors down and away from the user . Ventilation is simply tied into the ceiling m floor or wall using a flexible hose at one end of the dissection cart . With the built in slope , the table drains toward one end . A PVC stop valve is included . Stainless steel 304 is used through unless other wise specified . The elevating range is 90 cm ~120 cm .

Adjustable embalming table Specifications

Product	Adjustable embalming table
Model	YJ-ET104
Load Capacity	180 KG
Sink	Width 81 cm x Length 218cm x Height 87~119 cm
Material	Stainless steel 304

Adjustable embalming table Details



whatsapp/TEL.: 0086-18236758227
web: www.forermedchina.com cassie@yjcompany.com



Forever Medical

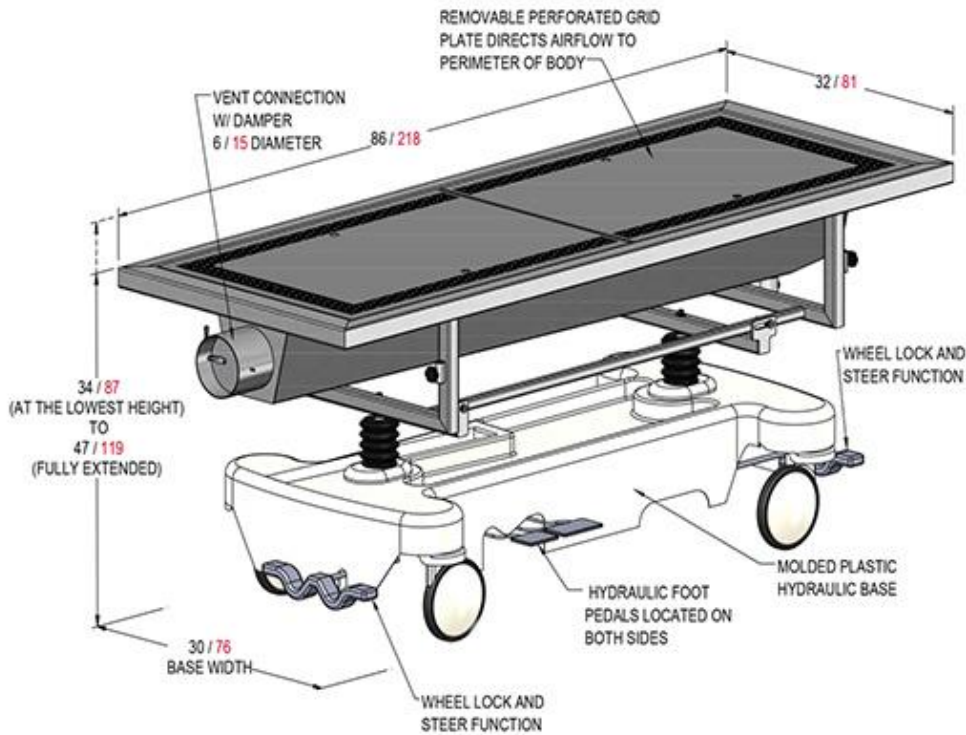

Adjustable embalming table Features

Table Top Downdraft : The top is 218*80 cm with a 2" recessed area . The 24" *79 " recessed area is designed to accept the perforated grid plates . The lower surface of the tabletop is the downdraft structure . The table top can be flat or sloped to various angles . The drain is no smaller than 1" NPT ball type PVC valve complete with serrated hose fitting.

whatsapp/TEL.: 0086-18236758227
web: www.forermedchina.com cassie@yjcompany.com



Forever Medical

Foot Controls : Dual side mounted foot controls allow for almost effortless elevating on either side . Dual locking levers lock all the wheels simultaneously from either end . The dissecting table top can be lowered in height to 90 cm ~120 cm

Undercarriage sub frame: The undercarriage sub frame is fabricated of 304 stainless steel . The "U " channel type design completely encases the recessed area of the table top . Continuous welds on all adjoining pieces . The structure can be elevated to high of 90 cm ~120 cm high

Perforated Grid Plates : : The perforated grid plate is fabricated of 304 stainless steel . The grid is perforated with ½ " diameter holes on square centers as shown in the drawing

Casters: Portable units are provided with 6 " diameter casters . Each wheels is heavy duty , all swivel toe casters , complete with swivel lock and / or wheel brake . The wheel material is impervious to embalming chemicals

Fabrication : All welding is TIG type using only stainless steel as a filler media . All exposed welds are ground smooth and regained to match the adjacent factory . Unexposed welds are brushed free of burrs and discoloration .

Ventilation : Ventilation is connected to the building ventilation system on one end of the dissecting table . The connection can be made to flexible duct that extends from the ceiling or floor , always opposite the drain



whatsapp/TEL.: 0086-18236758227
web: www.forermedchina.com cassie@yjcompany.com