



JV WITH KONKA
CHINESE STATE OWNED COMPANY

晟高中&英文安装指导

Installation Guide for SUNGO (CN & EN)

英文安装指导.....P01~P18
English Installation Guide.....P01~P18

中文安装指导.....P19~P36
Chinese Installation Guide.....P19~P36

与阳光同行，优化不停

GO WITH SUNSHINE, ALWAYS OPTIMIZED

Smart Optimizer SUNGO iOPT 800W & Data Gateway SUNGO GT Quick Installation Guide

Document version: SUNGO-iOPT>™ -V1-2024 EN
 Release Date: 2024.5

1 Product Overview

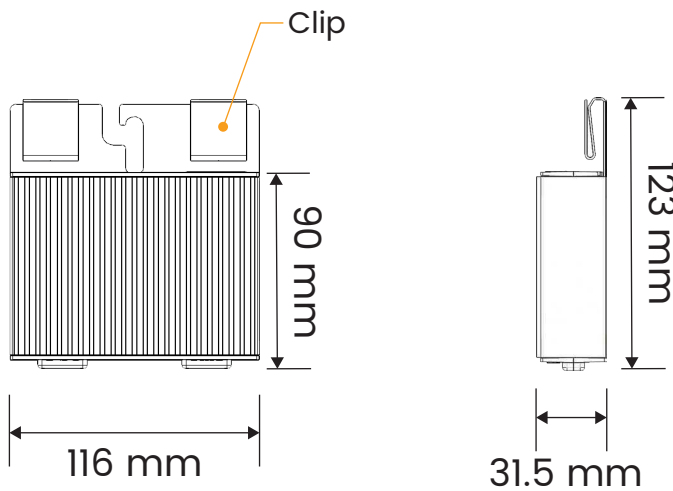

Model Description

SUNGO iOPT 800W
 -Smart PV Optimizer
 -Maximum Input Power 800W

Interface definition

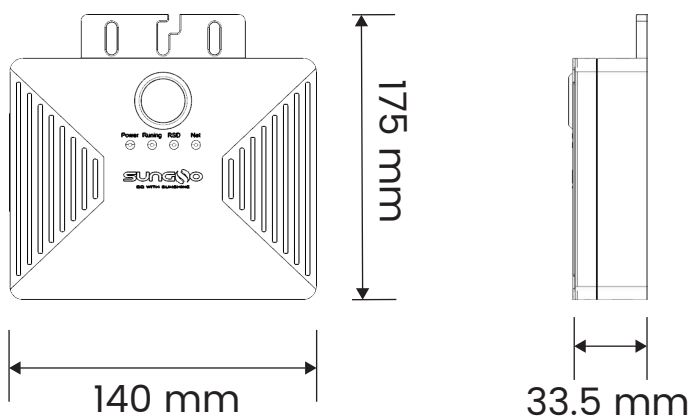
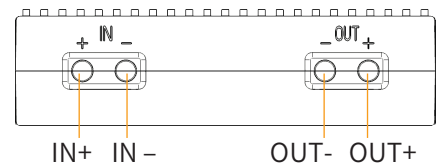

Model Description

SUNGO GT
 -Data Gateway

2 Install the Intelligent Optimizer iOPT

Step 1.

Before installing the optimizer, make sure the inverter is stopped (DC switch placed in OFF) and disconnect the inverter from the module array.

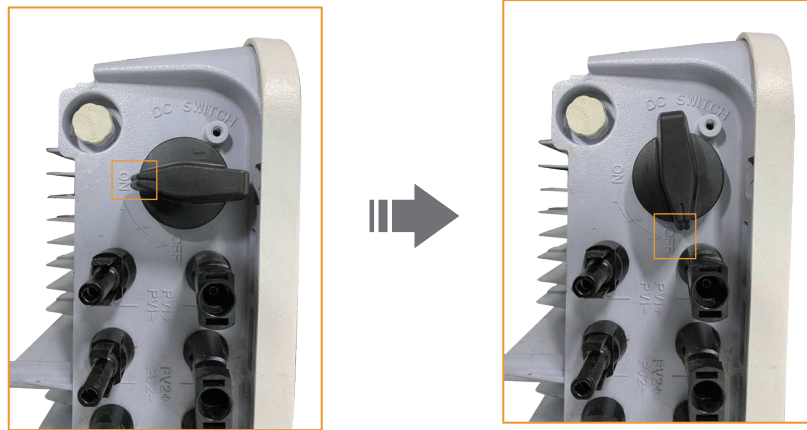

DC switch Placement in OFF position Schematic

Step 2.

Plan the optimizer installation location properly to ensure proper connection of cables between the optimizer, components, and neighboring optimizers.

Optimizer IN+: 200mm exposed IN-: 1100mm exposed OUT+ /OUT-: 750mm

Step 3.

After confirming the installation location of the optimizer and data gateway (Stay close to the strings and away from the inverter), start installing the optimizer and data gateway. At the same time remove the SN label and paste it to the physical layout template.

The physical location layout must be done at the time of installation for purpose 1: the physical location layout is required for the data gateway GT entry optimizer, and for purpose 2: it corresponds to the physical power station, so that the corresponding optimizer can be found in the event of a failure.

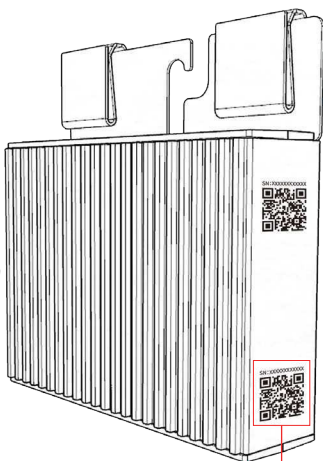

Note: If you need to mark information on the physical layout template, please use a marker pen

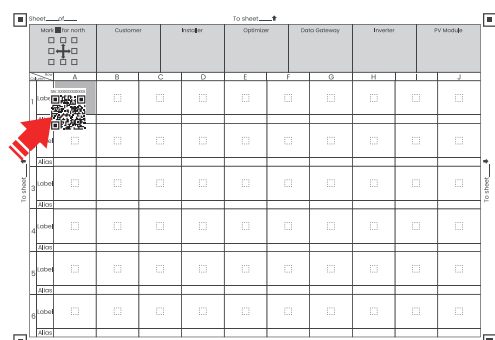

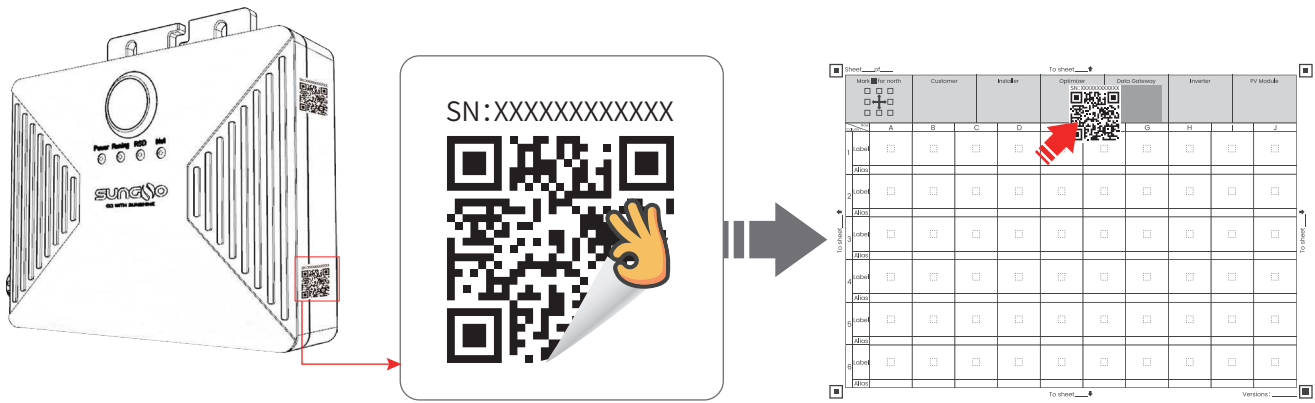

Step 4.

Mounting the optimizer to the PV panel bezel after removing the SN label - backside mounting.

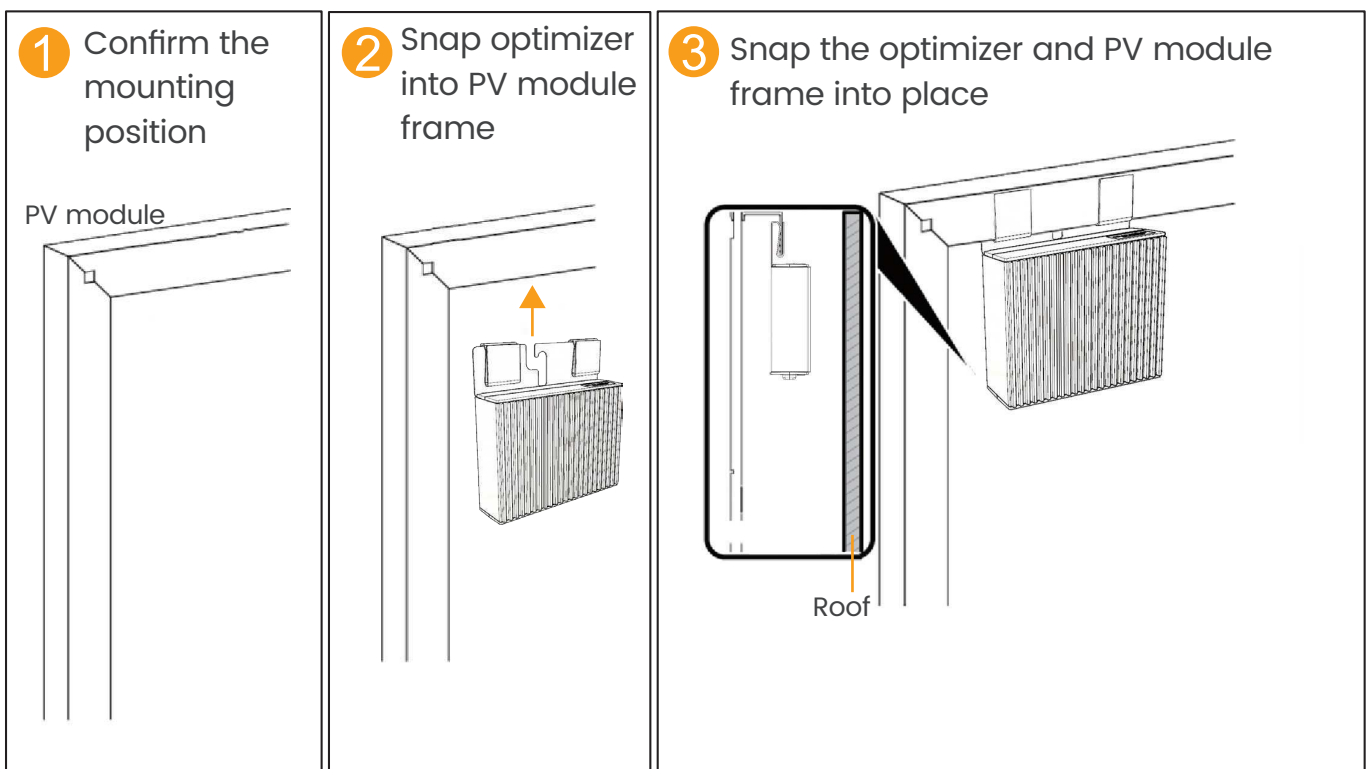

Attach the optimizer to the outer frame on the back of the PV through the clips and snap the clips completely into the frame to complete the installation.

3 Smart Optimizer iOPT Cable Connections

Step 1.

- Install the optimizer cable as shown below, otherwise the optimizer or the PV module may be damaged.

1. Connect the IN+ and IN- of the optimizer to the positive and negative terminals of the PV panel junction box correspondingly.
2. Connect OUT+ of the first optimizer to OUT- of the next optimizer.
3. Connect the cables of the other optimizers sequentially according to steps 1 and 2.

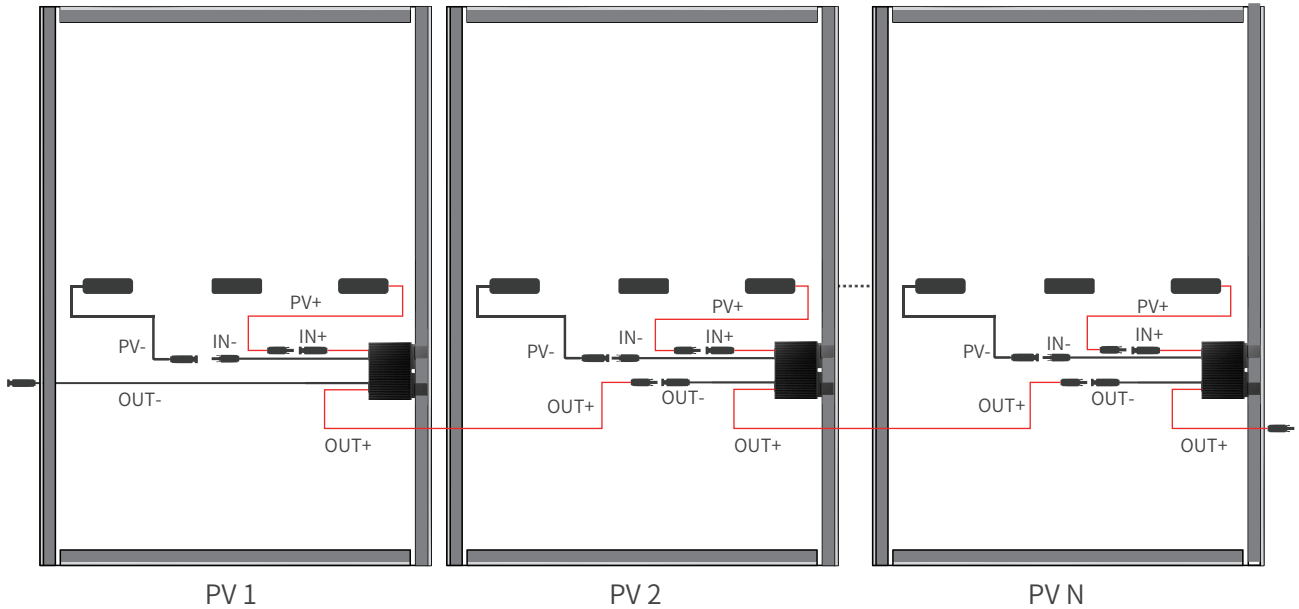

⚠ Caution!

In installation

Input cables of PV optimizer MUST be connected first, output cables of PV optimizer should be connected second.

In disassembly

Output cables of PV optimizer MUST be disconnected first, input cables of PV optimizer should be disconnected second.

Step 2. Optimizer Detection

1. Connect the optimizer input (IN) to the pv junction box.
2. Use the positive pen of the multimeter to connect the positive output of the optimizer, and the negative to connect the negative output, and check the output voltage of a single optimizer.

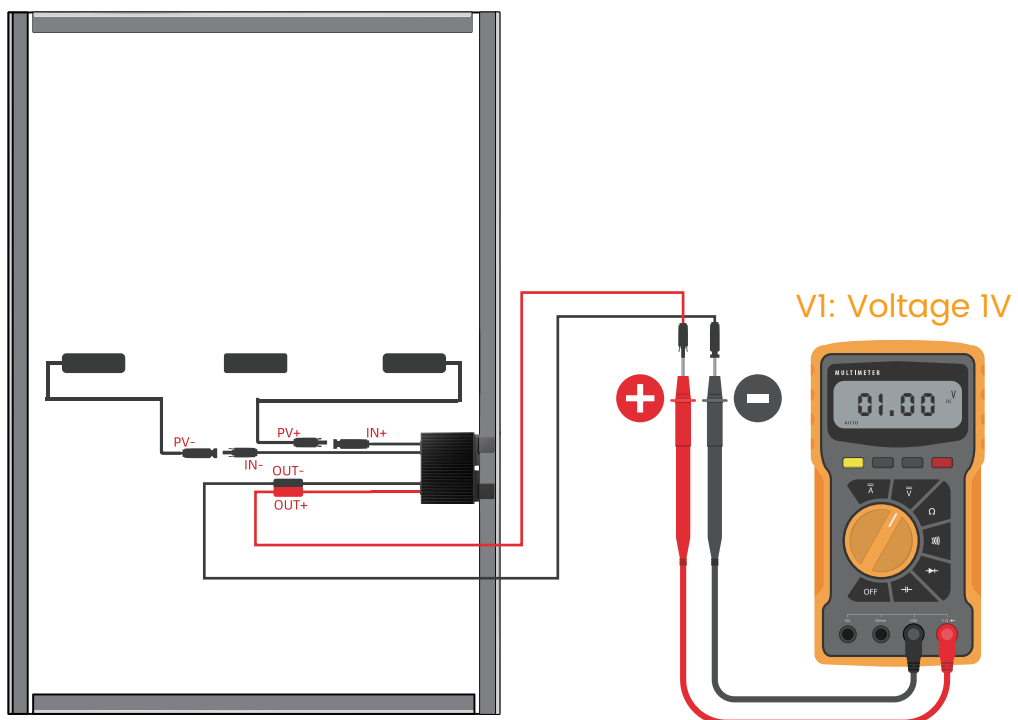

Voltage	Reason	Solve suggestion
$0.9V \leq V1 \leq 1.1V$	Optimizer normal	—
$V1 > 1.1V$	Optimizer fault	Replacement optimizer
$V1 < 0.9V$	<ul style="list-style-type: none"> ·Weak light ·optimizer input is not connected ·The optimizer is wired incorrectly ·Optimizer fault 	<ol style="list-style-type: none"> 1. Voltage is measured when light is sufficient. 2. Connect the optimizer input cable 3. Adjust the optimizer cable connection and connect the optimizer input cable to the PV module output 4. If the voltage is still abnormal, replace the optimizer
$V1 \approx -1V$	The multimeter pen is reversed	Multimeter pen positive and negative exchange

3. After confirming that the optimizer and the input cable are properly connected, connect the optimizer output cable. When the light is sufficient, the voltage of the photovoltaic string is measured.

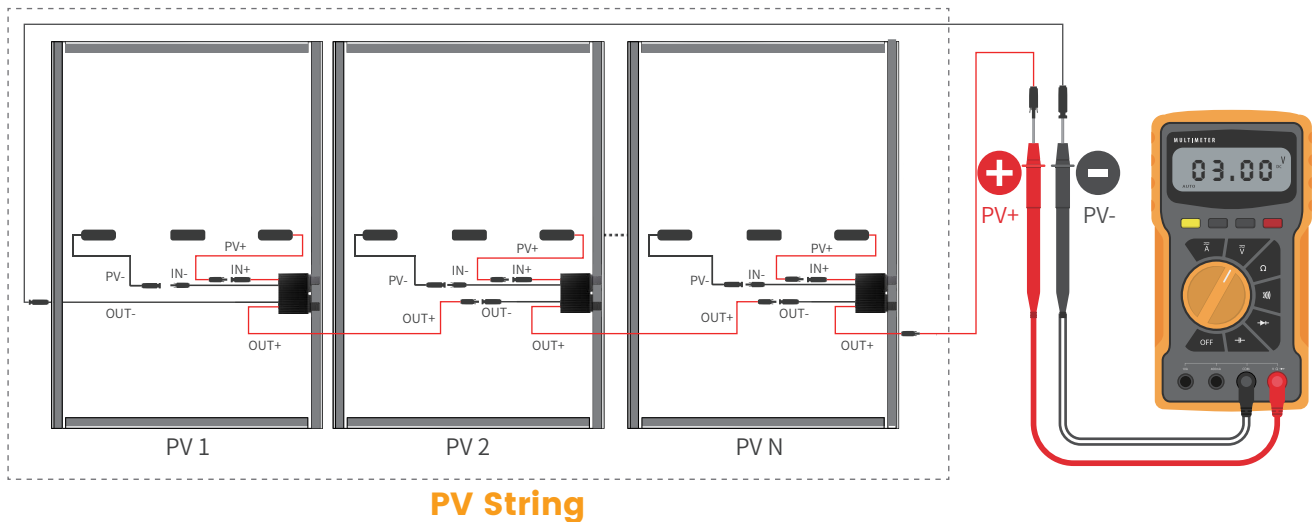

Voltage	Reason	Solve suggestion
The string voltage is 0	<ul style="list-style-type: none"> ·PV module strings have open circuit ·The cables are not in the same string 	<ol style="list-style-type: none"> 1. Check whether the group string is open circuit faulty 2. Connect the strings cables correctly
The string voltage is negative	<ul style="list-style-type: none"> ·The multimeter pen is reversed ·The label on the cable is incorrect 	<ol style="list-style-type: none"> 1. Multimeter pen positive and negative exchange 2. Make proper cable labels
The string voltage is less than the number of optimizers	<ul style="list-style-type: none"> ·Some optimizer input missed connections ·Some optimizer outputs miss connections ·Some optimizer outputs are connected opposite 	Check whether the PV modules and strings cables are correctly connected
The string voltage is greater than the number of optimizers	<ul style="list-style-type: none"> ·The actual number of optimizers in the group string is greater than the expected number ·The photovoltaic panel is not connected to the optimizer, and is directly connected to the group string 	<ol style="list-style-type: none"> 1. Check that the number of optimizers in the group string is correct 2. Check whether the PV modules and series cables are correctly connected

4 Installing the GT and connecting the strings to the inverter

1. install the GT near the inverter.
2. connect the OUT+ of the last optimizer to the PV+ of the inverter.
3. Connect the OUT- of the first optimizer to the PV- of the inverter through the magnetic ring of the GT.
4. After confirming that the connection is correct GT connects the MCB and then connects it to the AC.

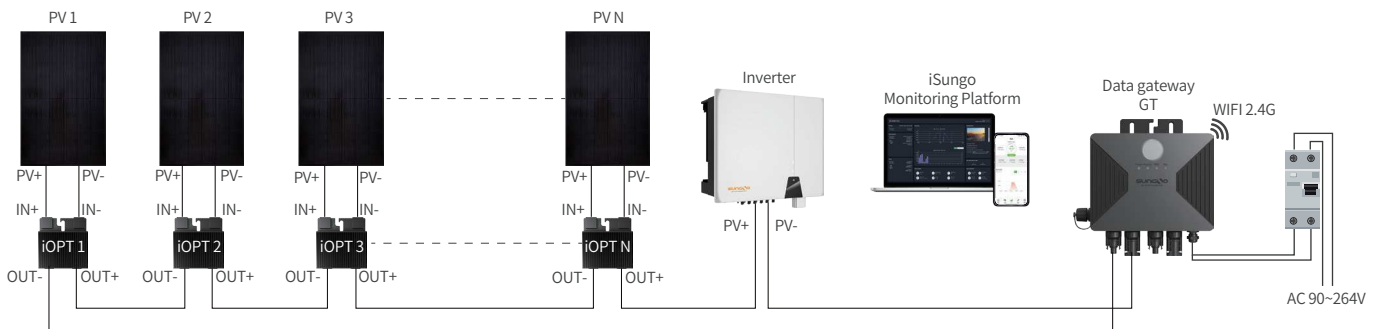

System Wiring Diagram

The GT itself is IP67 waterproof and can be used without a distribution cabinet. The AC input line is connected to the AC power using the L16-2 waterproof connector.

- Check that the structural mounts are secure and that all screws are tightened.
- Check that all cables are connected with the correct polarity and that the connections are firm and reliable to ensure that there are no short circuits.

5 System power-up and product management

Step 1. Turn on the inverter

Confirm that the system is connected correctly, the inverter DC switch is ON, and the inverter is turned on.

Step 2. Connecting the data gateway to a power source

Connect the data gateway to 90~264V AC power supply. Ensure that the power indicator green light is always on, and the running indicator green light is also always on. Check whether the inverter is working normally.

Step 3. GT status indication



Four permanently illuminated status indicators from left to right (1, 2, 3, 4)



Note: Indicator status indicates

1, 2, 4 Indicator status schematic: ● Indicates normally lit ● Indicates extinguished ● Indicates blinking	
3 Indicator status schematic: ● Indicates normally lit ● Indicates extinguished ● Indicates blinking	
<p>None of the four indicator lights are lit Wrong or faulty circuit connection</p>	<p>1 on 2 off 3 on 4 on Turn off the optimizer, the network is connected normally</p>
<p>1, 2 on 3, 4 off Start optimizer, network not connected</p>	<p>1 on 2 blinking 3 blinking 4 blinking Search Optimizer self-test</p>
<p>1, 2 on 3 off 4 on Start the optimizer, the network is connected normally</p>	<p>1 on 2Blinking 3on 4 on or off Search Optimizer self-test successful</p>
<p>1 on 2 off 3 on 4 off Optimizer off, network not connected</p>	<p>1 on 2 off 3 blinking 4 on or off Search Optimizer self-test failed</p>

Step 4. GT Entry Optimizer

The GT needs to enter the address of the optimizer it manages, otherwise it can't communicate and upload the optimizer's data normally. There are two ways to enter optimizers: **automatic and manual**. When there is only one GT in the field, you can use the automatic optimizer, but if there are more than one GT in the field, you **must execute** the manual optimizer.

Auto Entry Optimizer (GT=1)

Press the middle button of GT to let the Running light always on, let the RSD light go out, after 5 seconds and then long press the button, GT enters into the automatic recording mode, release the button, the indicator light 234 flashes back and forth waiting for about 10 minutes the Running indicator light flashes to indicate the success of the automatic recording, press the button again to the Running indicator light is always on, the Optimizer is working normally. If the indicator light 3 blinking means that this automatic recording failed please check the line and re-execute the step, if three times are not successful please contact the relevant technical personnel.

Manual entry optimizer (GT>1)

Note: If the automatic optimizer entry function is used, it will cause conflicts by duplicating the optimizers that are managed by each of the multiple GTs in the field, and you only need to re-execute the operation of manually entering the optimizers. (Manual entry of optimizers is to enter the optimizers in the field into different GTs)

I. Process

Recommended application process:

1. First power up the GT.
2. Use the USB to RS485 cable to connect GT and the computer
3. Select the corresponding serial port
4. Read MAC Addr and Version, if normal display, represents the current connection is normal, otherwise check whether the cable is properly connected.
5. Enter the IOPT code into the List list, and then click Write to write it to GT; there are two ways to enter the code as follows
 - ① Through Import button, recognize the selected picture to import.
 - ② Enter the number manually through the keyboard, and note that each number is separated by a comma.
6. Monitor the current status of the optimizer through To Monitor.

II. Wiring

Use USB to RS485 to connect the GT to the computer, the connection is shown below:

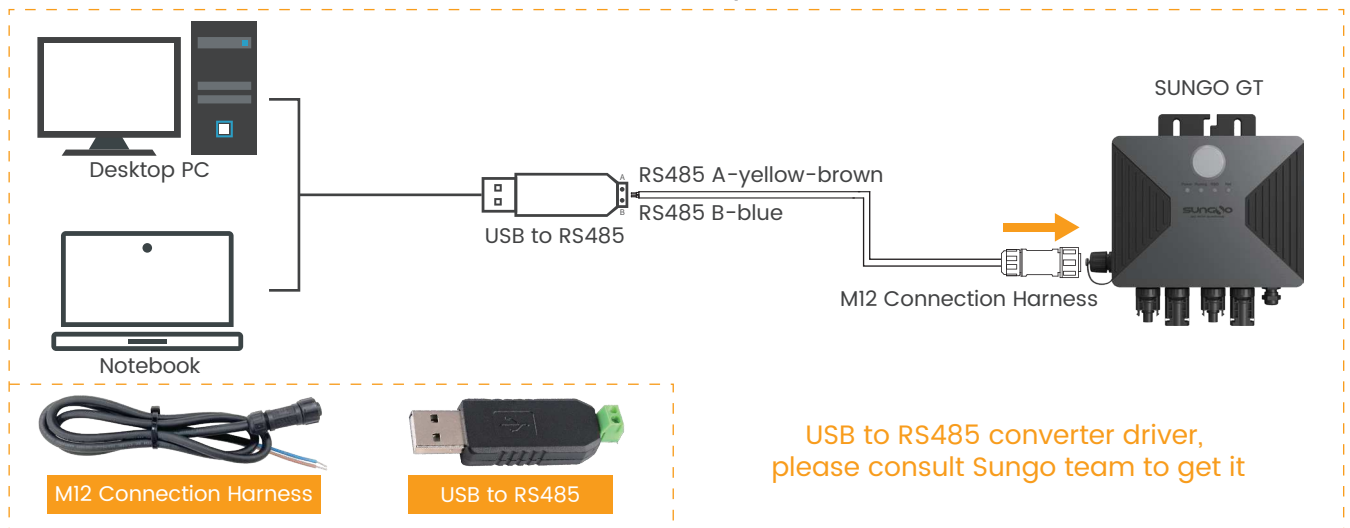

Wiring Diagram

III. Description

1. Select the corresponding serial port After success, the green circle is displayed as follows

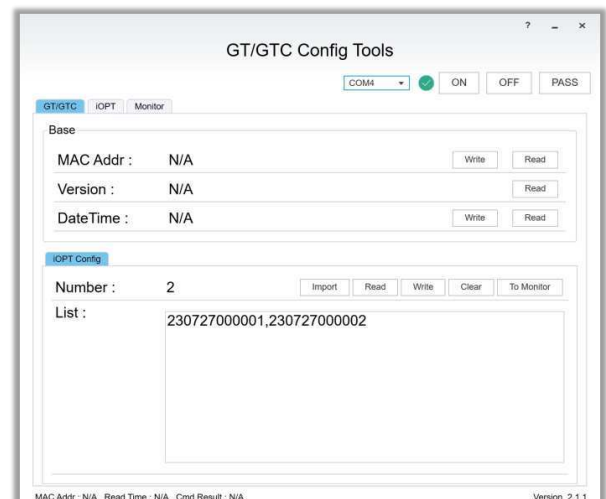
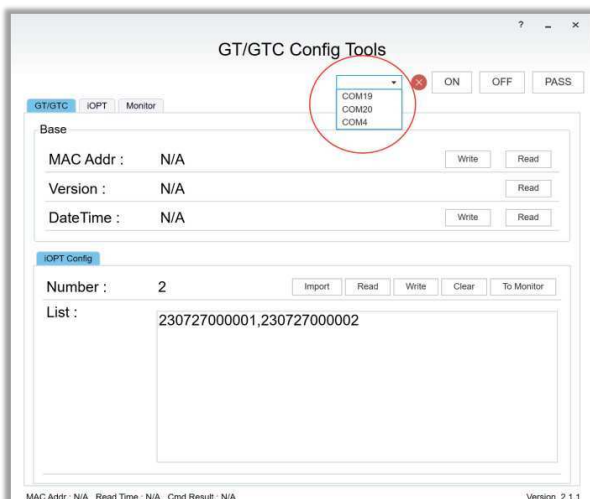

2. Description of GT functions

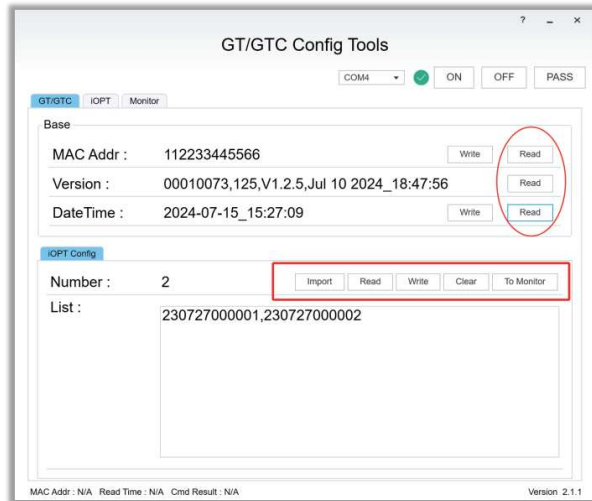

①MAC Addr:

Click Read to read the address of GT, and click Write to write the address in the left input box to GT.

②Version

Click Read to read the software version number of GT.

③DateTime

Click Read to read the time of GT, and click Write to write the system time into GT.

④iOPT Config - Import

Click Import to import the iOPT code through the image, as follows
Click Import to import the recognized codes into the List box.

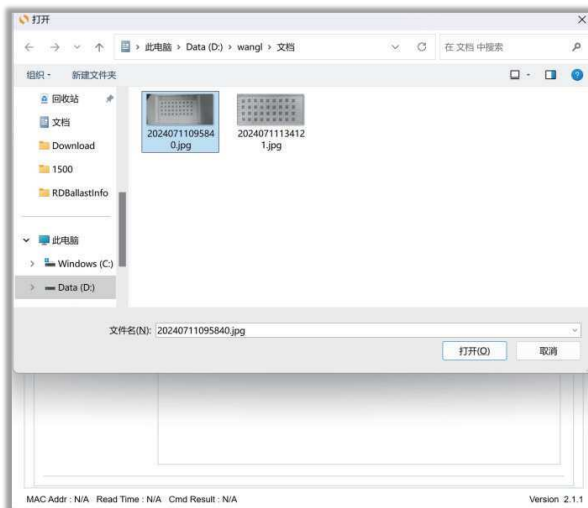

⑤iOPT Config - Read

Click Read to read the iOPT list of the current GT configuration.

⑥iOPT Config - Write

Click Write to write the iOPT list to GT.

⑦iOPT Config - Clear

Click Clear to delete all the iOPTs in GT.

⑧iOPT Config - To Monitor

Click Monitor to display the iOPTs in List on the Monitor page.

3. Read single iOPT working parameters function description

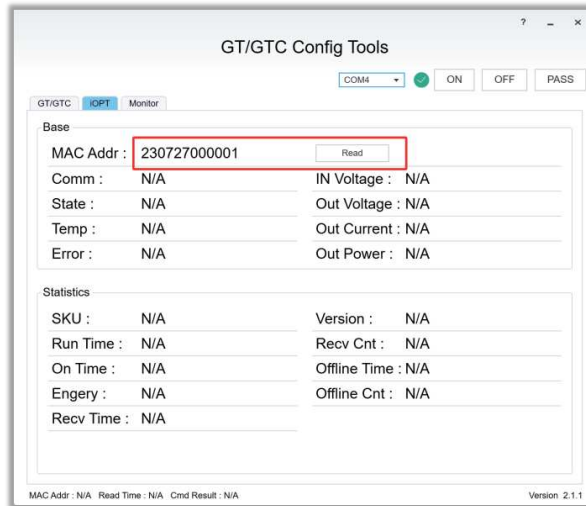

Input the iOPT number you need to read, click Read to read its current status.

Comm: communication status, Online stands for online, Offline stands for offline.

State: current state, ON working, OFF closed.

Temp: current temperature, Celsius degrees

Error: current fault, Normal stands for normal.

IN Voltage: input voltage

Out Voltage: Output Voltage

Out Current: Output Current

Out Power: Output Power

SKU: Product Model

Run Time: Run Time

On Time: Working Time

Engery: Power Generation

Recv Time: Receive Time

4. Monitor Function Description

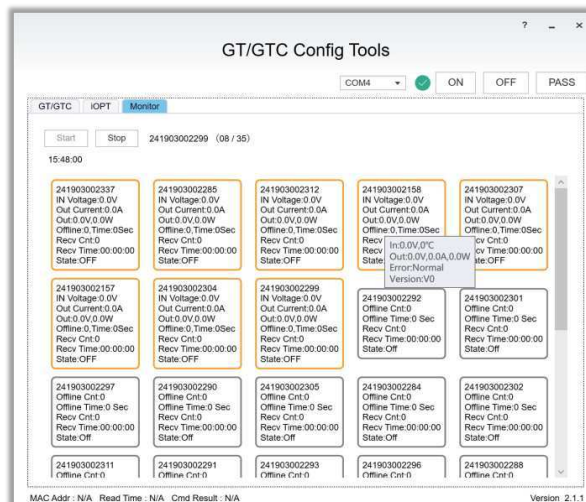

Click Start to start monitoring, the software will refresh the status of iOPT in List regularly.

6.1 GT distribution network (APP1.0 instructions for use)

Step 1. Download APP and register account



iSungo-Android



iSungo-ios

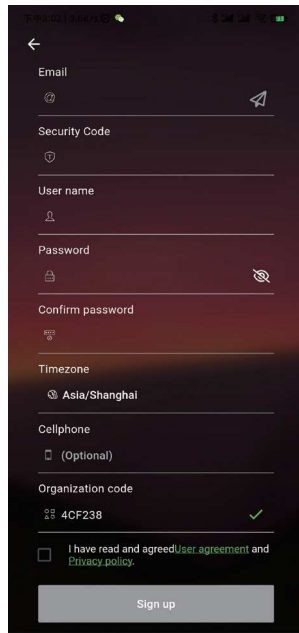

Scan the QR code to download APP

Open the APP to register an account

Step 2. Creation of PV power plants



Click on the top right corner to create a power station

Step 3. Fill in the power station information

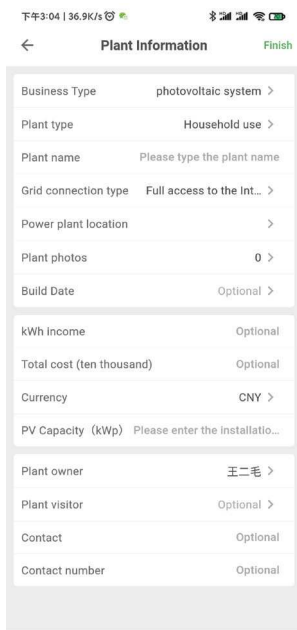

Step 4. Sweeping Code Collection Data Gateway



WIFI Serial Number:
XXXXXXXXXXXXXXXXXX

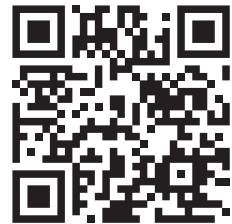

Example of QR code on the left side of GT

Click the arrow on the right side of the power station, scroll down, and click 'Add Collector.' Then, scan the WIFI serial number on the left side of the Data Gateway GT by using the QR Code.

Step 5. GT WIFI Distribution Network

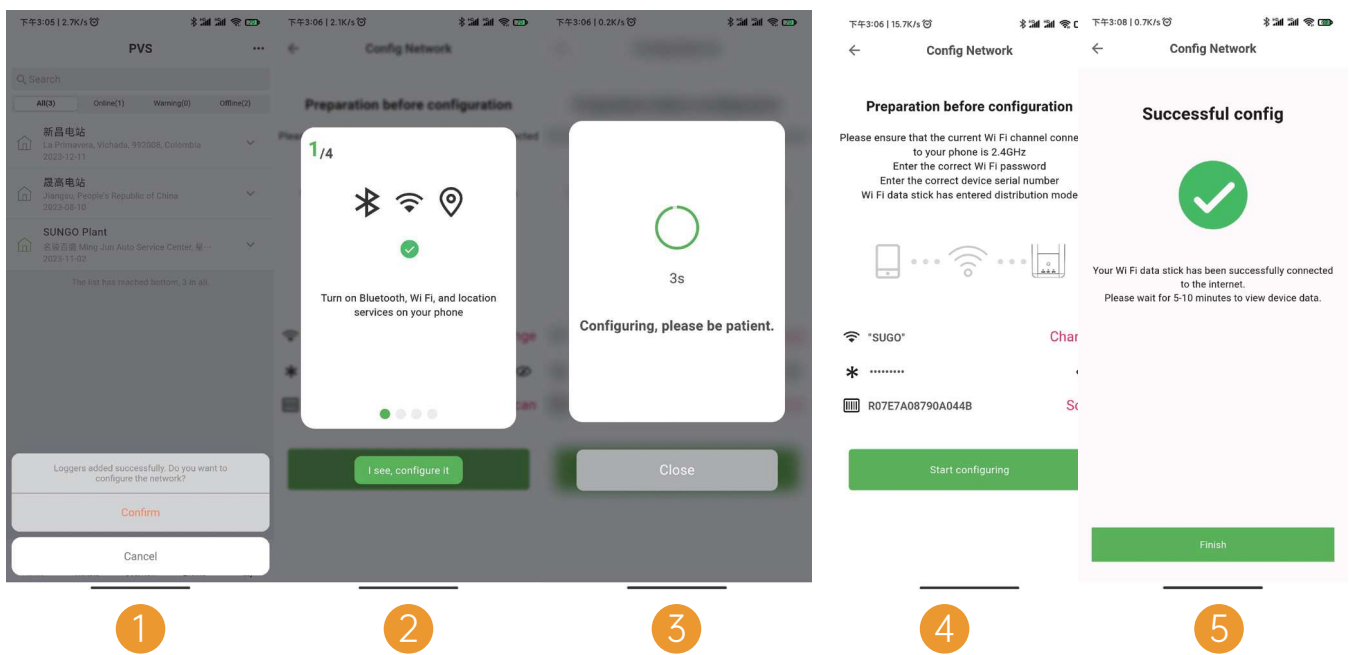

Just follow the instructed process to show the successful distribution of the network.

Step 6. Optimizer Status View

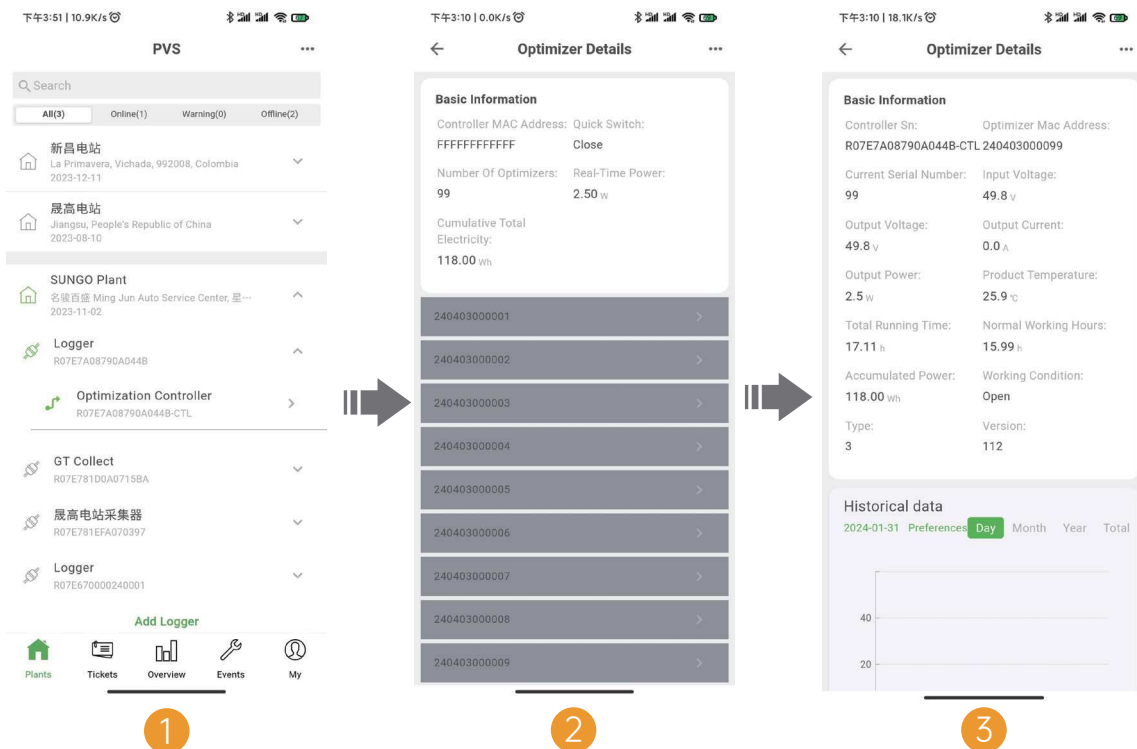

After successful grid distribution, click on the arrow to the right of the power station project until the optimizer controller appears, then click on the optimizer controller, then click on the Optimizer Code to view the optimizer details.

Step 7. Check the status of the power station

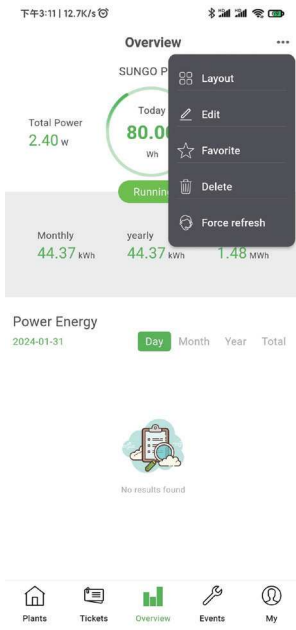

Click on APP OVERVIEW, then open the drop-down menu in the upper right corner of the page. Click on the layout to see the status.

After clicking Layout, the status of the power plant is displayed in several states as shown below.

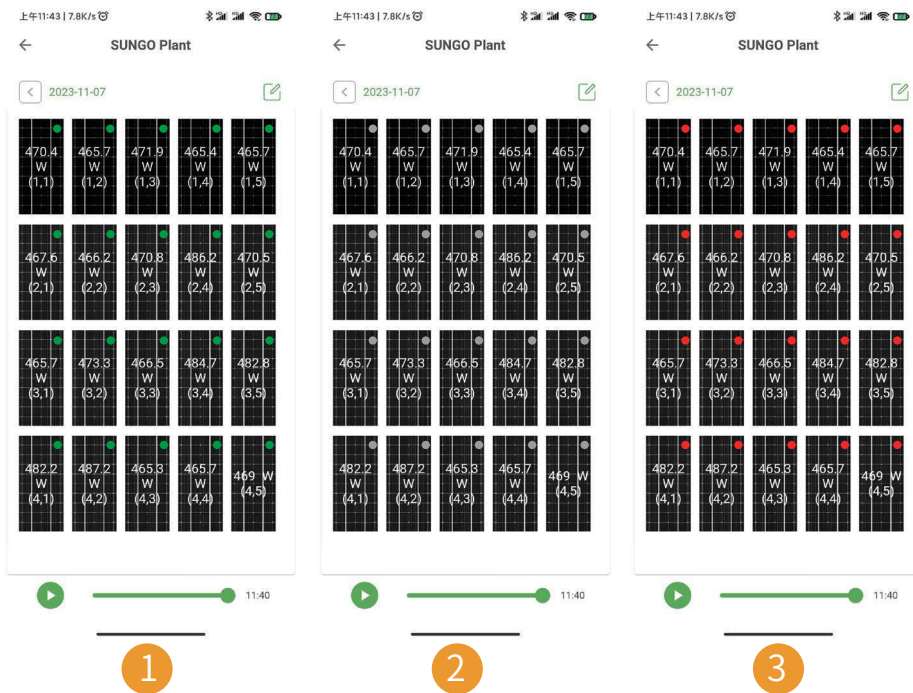

State of affairs	Clarification
Figure 1 - Green circle in the upper right corner	Optimizer is running fine
Figure 2 - Gray circle in the upper right corner	Optimizer is offline, please check that the SN and location information is correct and then search the device again!
Figure 3 - Red circle in the upper right corner	Optimizer failure, need to replace optimizer

6.2 GT distribution network (APP2.0 instructions for use)

Step 1. Download APP and register account

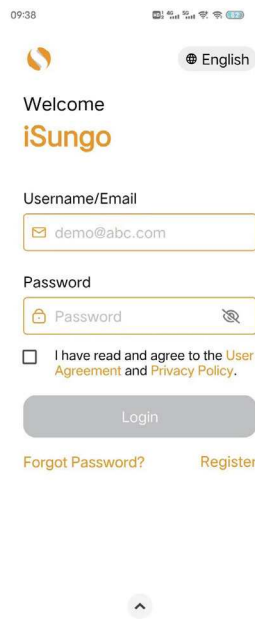

Scan the QR code to download APP

Open the APP to register an account

Step 2. Creation of PV power plants

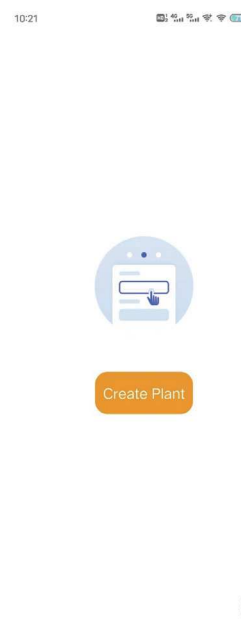

Click to create a power station

Step 3. Filling in power plant information

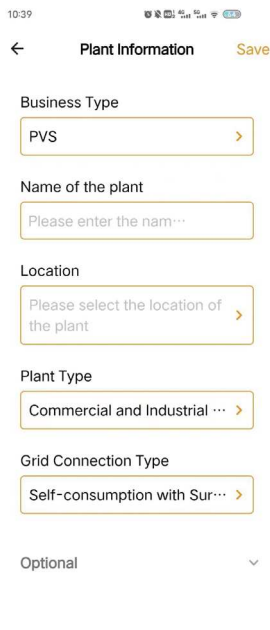

Just fill in the information according to your own power station

Step 4. Scanning the data collection gateway

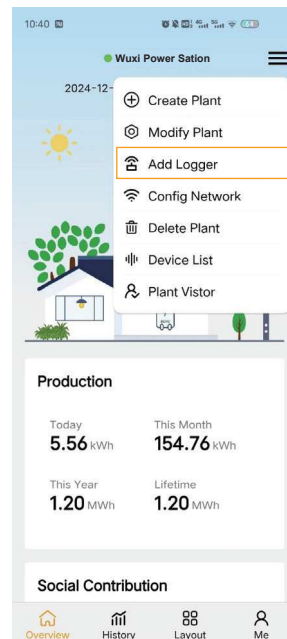

WiFi Serial Number:
XXXXXXXXXXXXXXXXXX



Example of QR code on the left side of GT

Click the drop-down menu in the upper right corner, click "Add Logger", and scan the QR code of the WIFI serial number on the left side face of the Data Gateway GT

Step 5. GT WIFI distribution network

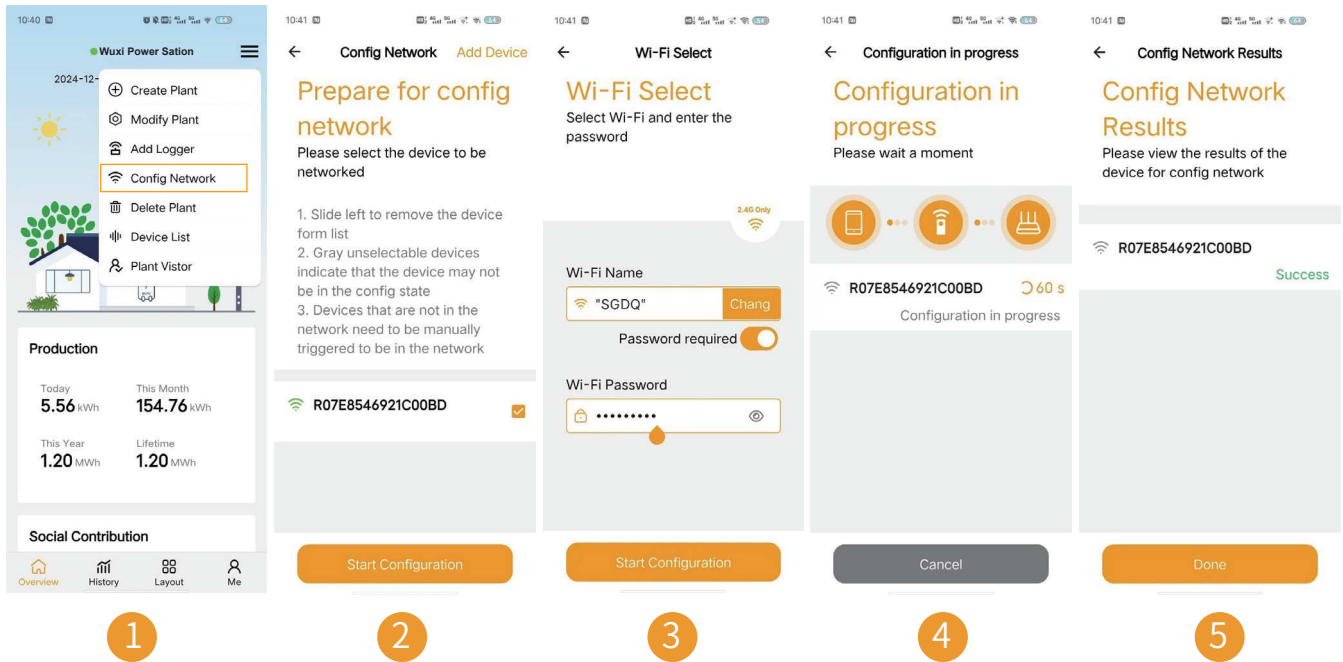

First, click on the drop-down menu in the upper right corner of the "Overview" page, and then click on "Configuring Network". Operate according to the indicated process. It will be okay as long as the successful network configuration is displayed

Step 6. Optimizer Details

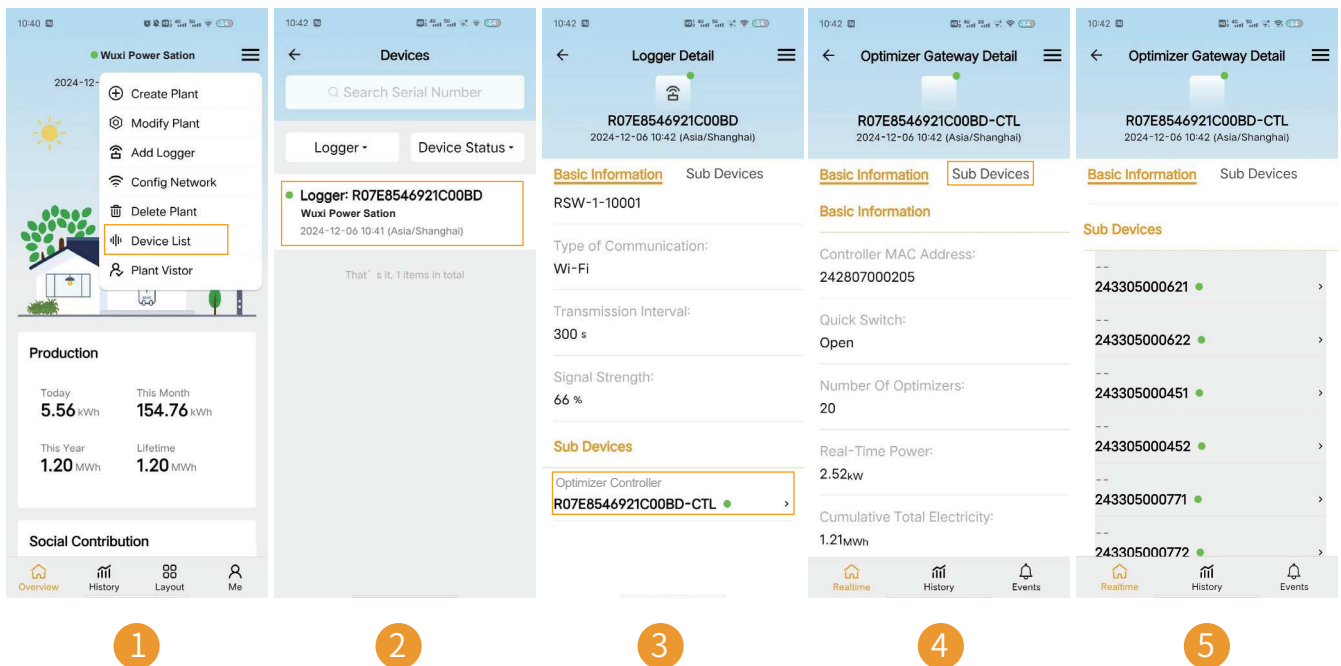

1. Click on the drop-down menu in the upper right corner on the "Overview" page, and then click on "Device List"
2. Click on the "Logger" column to enter the collector details page
3. Click on the "Optimizer Controller" under "Logger Details" to enter the "Optimizer Gateway Detail" page
4. Click on "Sub Devices" and you can see the optimizer serial number
5. Click on the arrow on the right side of the optimizer serial number to enter the "Optimizer Detail" page

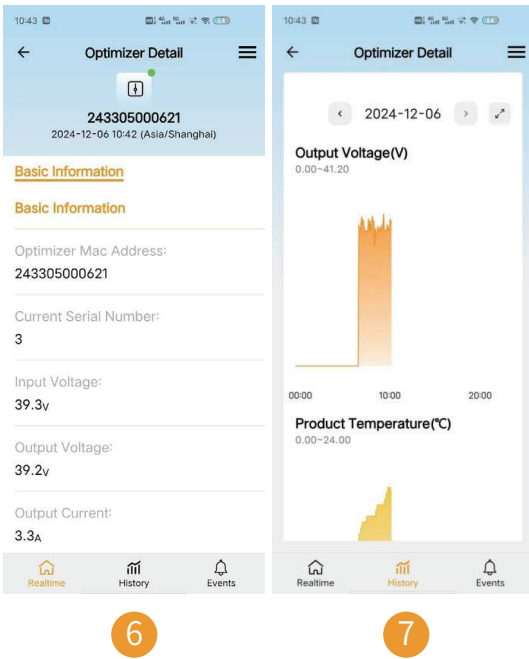

6.The device information will be displayed on the "Optimizer Detail" page

7.Click on the "History" icon at the bottom to view the graphical display of the "Optimizer Detail" (showing input voltage, output voltage, temperature, output current and output power)

Step 7. Observation of the status of the power station

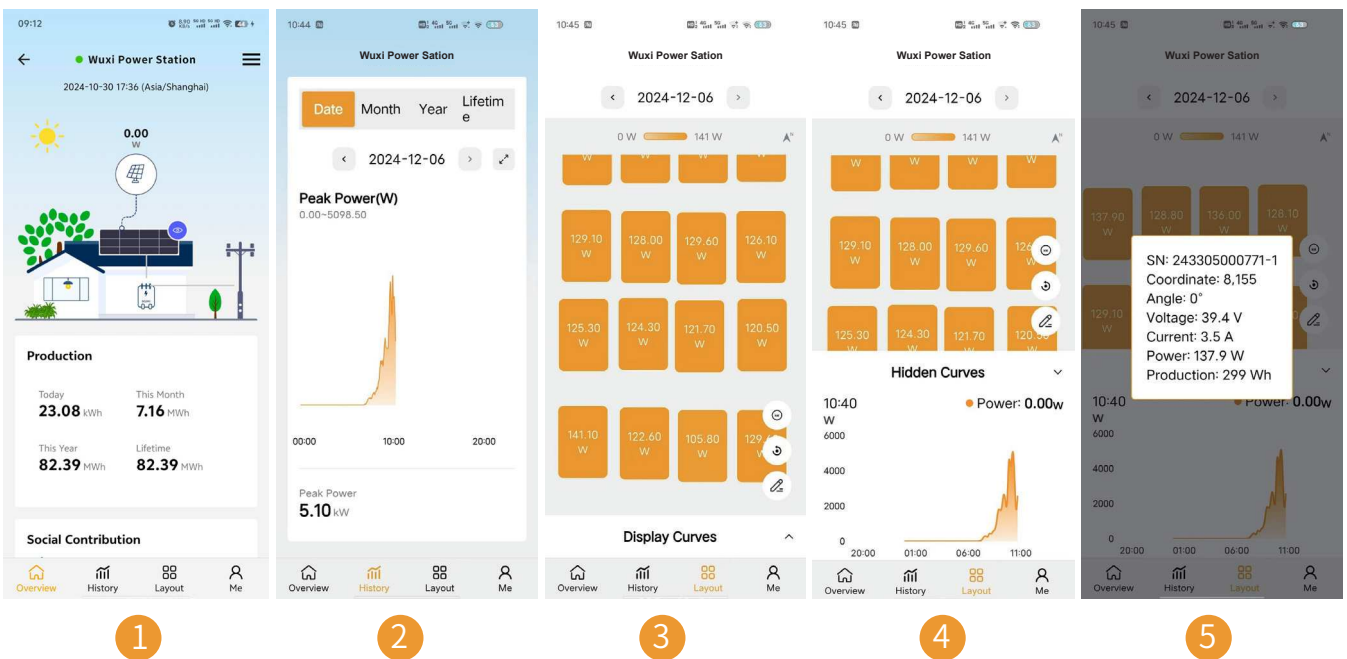

1.Return to the "Overview" page and you can see the basic information about the power generation of the power station

2.Click on "History" on the right side of the "Overview" in the APP and you can see the peak power of the power station

3.Click on "Layout" on the right side of "History" in the APP and you can see the status of the photovoltaic modules

4.Click on "Display Curves" and you can see the power curve of the modules

5.Long-press on the "Photovoltaic Module Graph" and the detailed information of the modules will be displayed

Step 8: Layout modifications

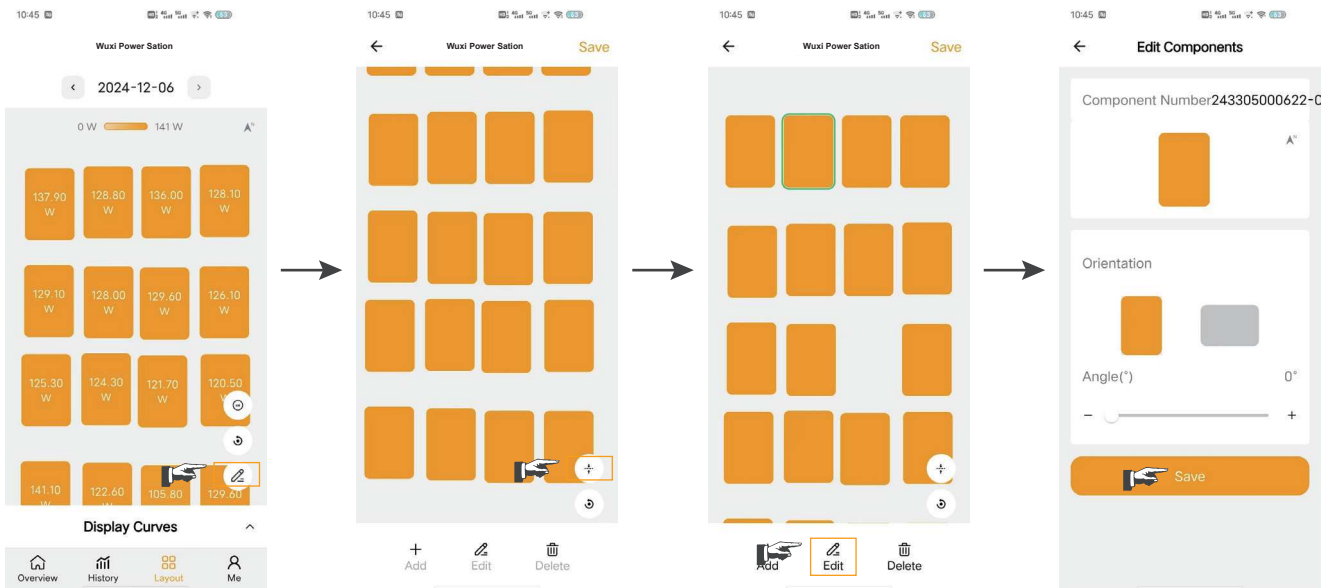

Click on the small icon here to modify the layout

Click on the small icon here. There will be a dotted grid to facilitate the layout

Click on "Edit"

You can modify the angle of the components. Save it after the modification is completed

Other functions

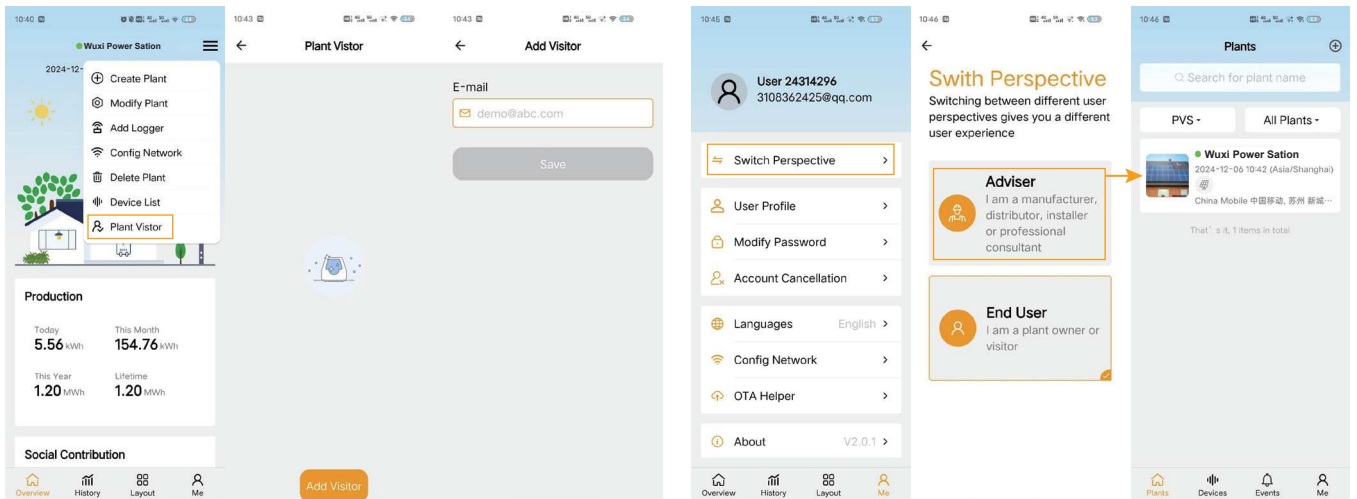

Add visitor's email address

Switch perspectives, that of professional consultants and end users

All the above steps are operated based on end users

Global Headquarters

SUNGO Energy Technology (Jiangsu) Co., Ltd.

Add: Unit 01, Floor 1, NO.179 Suhong West Road, Suzhou Industrial Park, Suzhou City, Jiangsu Province, China

Europe Headquarters

SUNGO Energy Technology B.V.

Add: Hoofdweg-Noord 9T, 2913LB Nieuwerkerk aan den IJssel, The Netherlands

Optimizer&Energy Storage Production base

KONKA&SUNGO Smart Energy (Zhejiang) Co., Ltd.

Add: Building 3#, Small and Micro Industrial Park, No. 69 Xingmei Avenue, Chengtan Street, Xinchang County, Shaoxing City, Zhejiang Province, China

Sungo Energy UK

Add: 60 Windsor Avenue, London SW19 2RR, United Kingdom

Sungo Energy Japan

SungoEnergy株式会社

Add: 4-16-5-206 Sekimae, Musashino City, Tokyo

Sungo Energy USA

SUNGO ENERGY TECHNOLOGY INC.

Add: 5900 Balcones Drive, STE 100 Austin TX 78731

Web: www.sungoess.com

E-mail: sales@sungoess.com

Global Headquarters Tel: +86 (0)512 6512 2036

Europe Headquarters Tel: +31 (0)10 307 21 68

SUNGO Energy UK Tel: +44 (0) 330 122 6559

After-sales e-mail: after-sales@sungoess.com



Linkedin



Facebook



Tiktok



Youtube

© Sungo reserves all rights. All other trademarks mentioned in this document are trademarks of their respective owners. The information in this document is for reference only and does not constitute any offer or commitment. Sungo may modify the above information without prior notice.

智能优化器SUNGO iOPT 800W和数据网关 SUNGO GT快速安装指南

文档版本: SUNGO-iOPT>™-V1-2024 CN
发布日期: 2024.5

1 产品概述

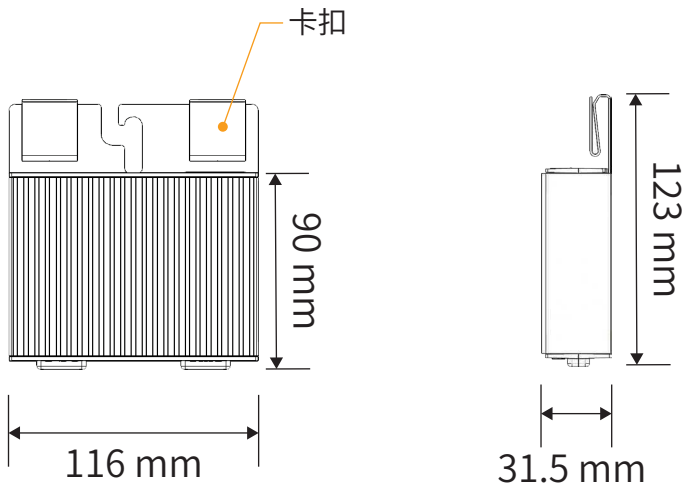

型号说明

SUNGO iOPT 800W
-智能光伏优化器
-最大输入功率800W

接口定义

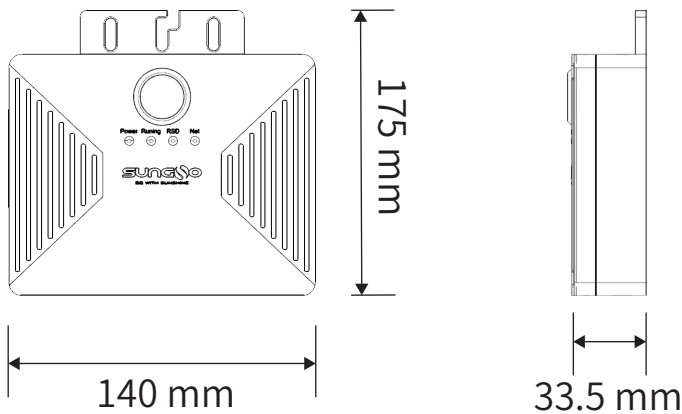
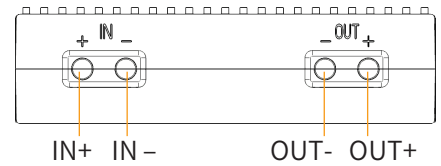

型号说明

SUNGO GT
-数据网关

2 安装智能优化器iOPT

步骤1.

安装优化器前,先确保逆变器停机(DC开关置于OFF档),并断开逆变器与组件阵列的连接。



步骤2.

合理规划优化器安装位置,确保优化器和组件之间的线缆以及相邻优化器的线缆可以正常连接。优化器IN+: 线长200mm IN-: 线长1100mm OUT+/OUT-: 线长750mm。

步骤3.

安装优化器和数据网关的同时取下SN标签,并粘贴到物理布局模板上。

安装时必须要做物理位置布局,目的1:数据网关GT录入优化器需要用到物理位置布局,目的2:对应到实体电站,当发生故障时可以找到对应的优化器。

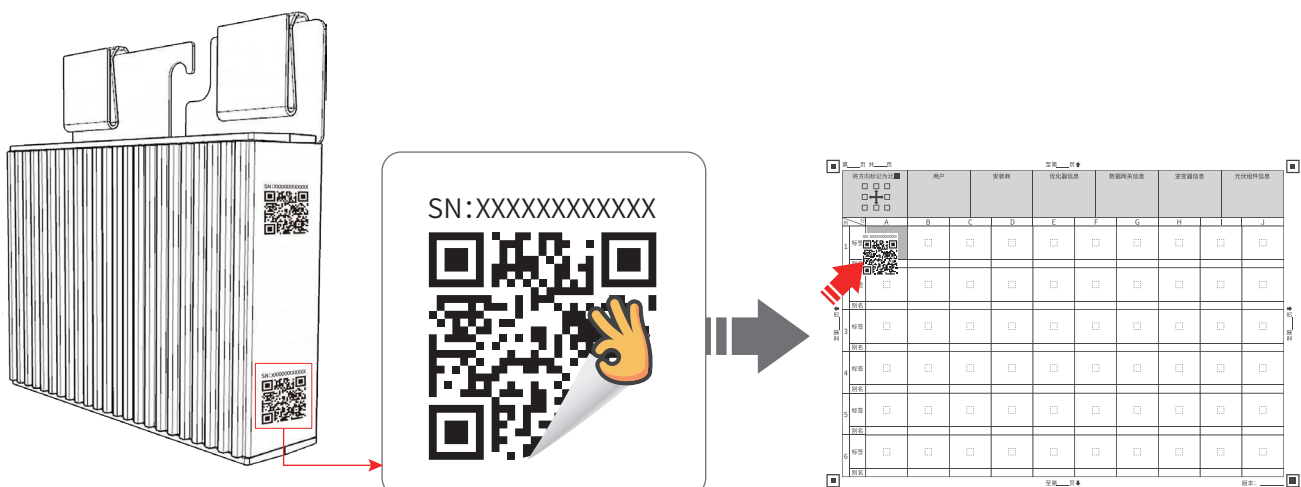

注:如果需要在物理布局模板上标注信息,请用记号笔

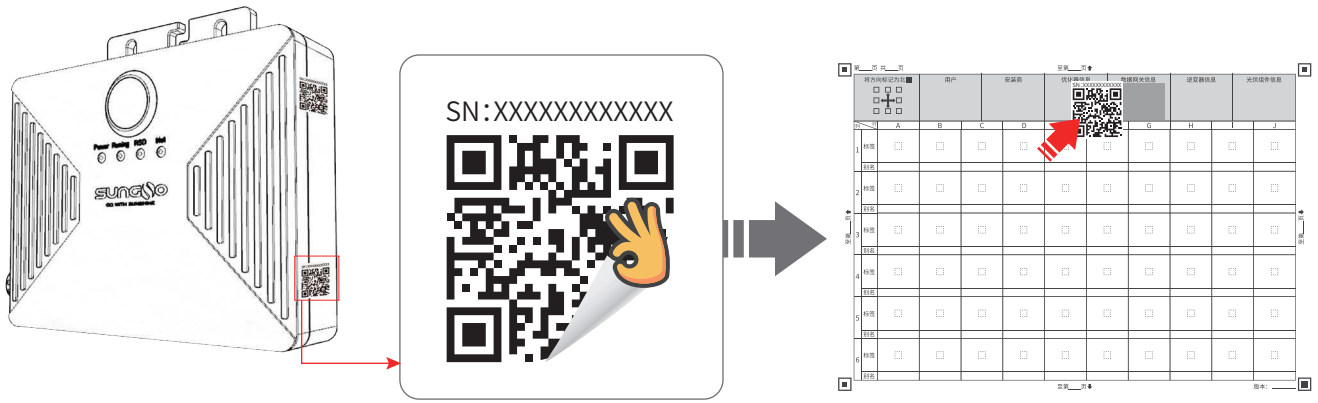

步骤4.

取下SN标签后将优化器安装到光伏板边框-背面安装。

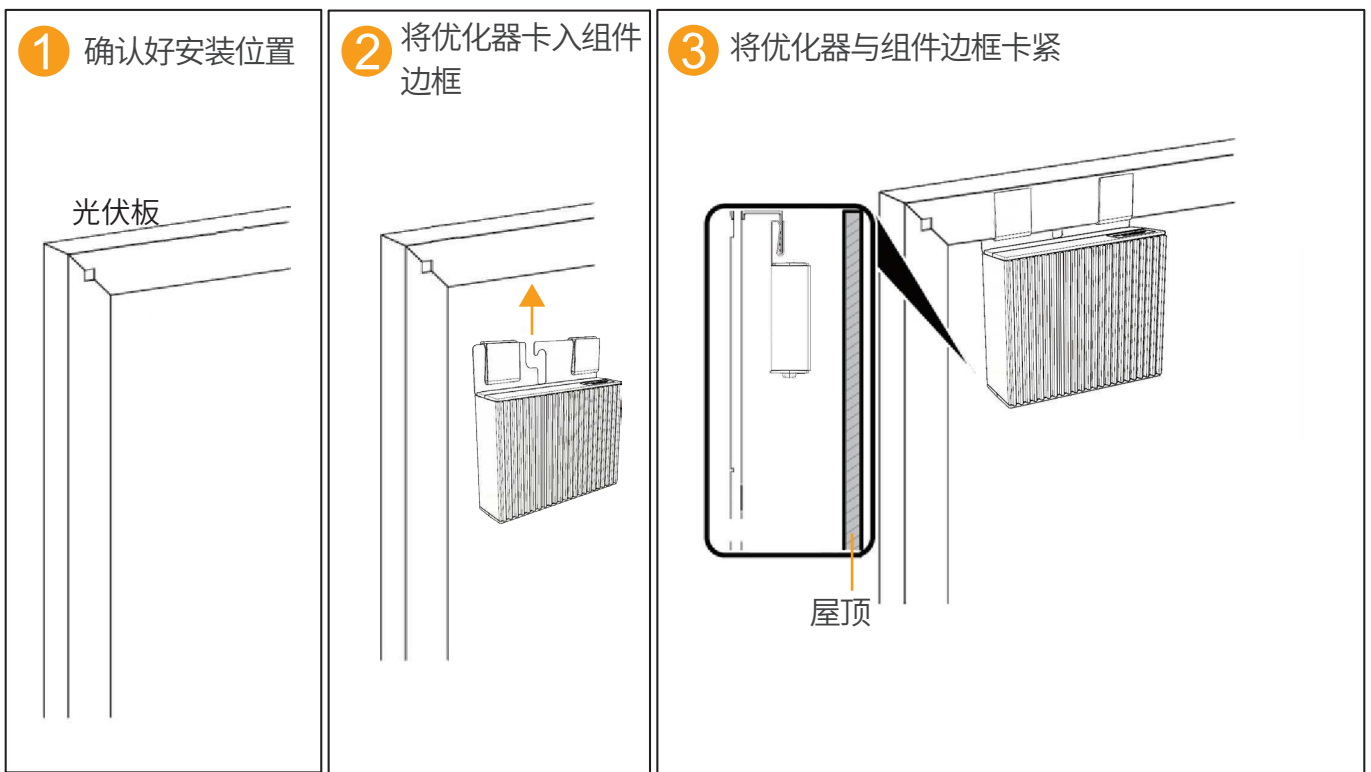

将优化器通过卡扣卡在光伏背面的外框上, 将卡子完全卡入外框即安装完毕。

3 智能优化器iOPT线缆连接

步骤1.

- 请按照如下图示安装优化器线缆, 否则可能会损坏优化器或光伏组件。
- 1. 将优化器的IN+与IN-对应连接到光伏板接线盒的正负极接线端。
- 2. 将第一个优化器的OUT+连接到下一个优化器的OUT-。
- 3. 按照步骤1和步骤2依次连接其他优化器的线缆。

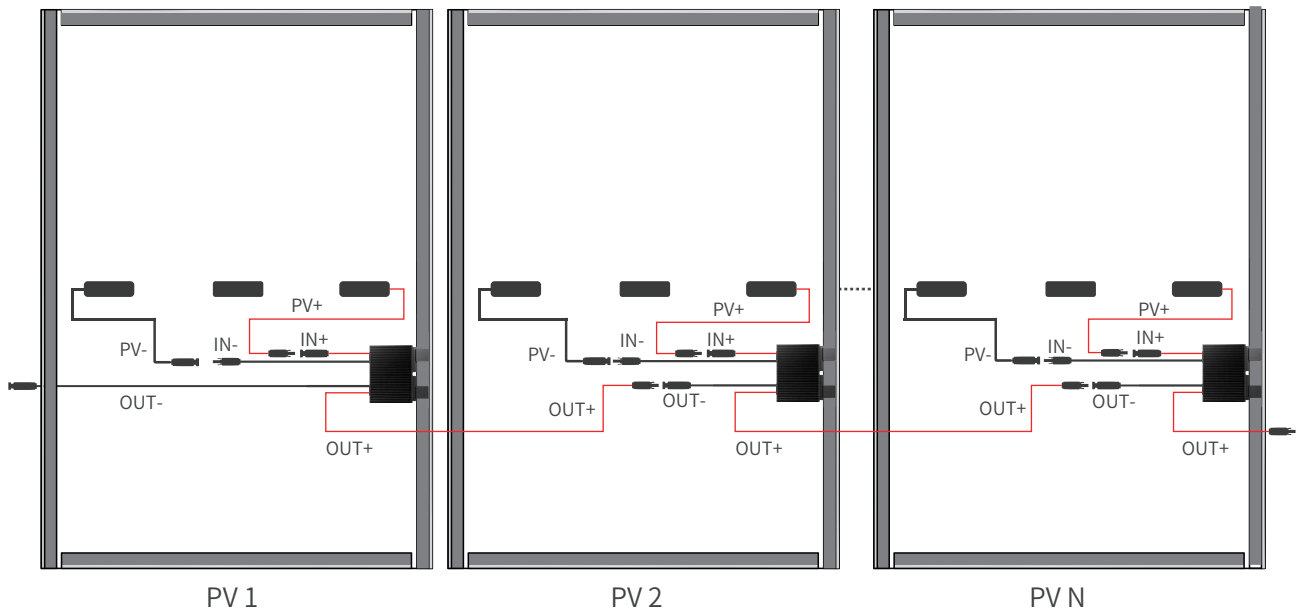

⚠ 注意!

安装时
必须先连接优化器的输入线,再连接优化器的输出线。

拆下时
必须先断开优化器的输出线,再断开优化器的输入线。

步骤2. 优化器检测

1. 将优化器输入 (IN) 连接光伏接线盒。
2. 使用万用表正表笔连接优化器输出正极, 负表笔连接输出负极, 检查单个优化器输出的电压。

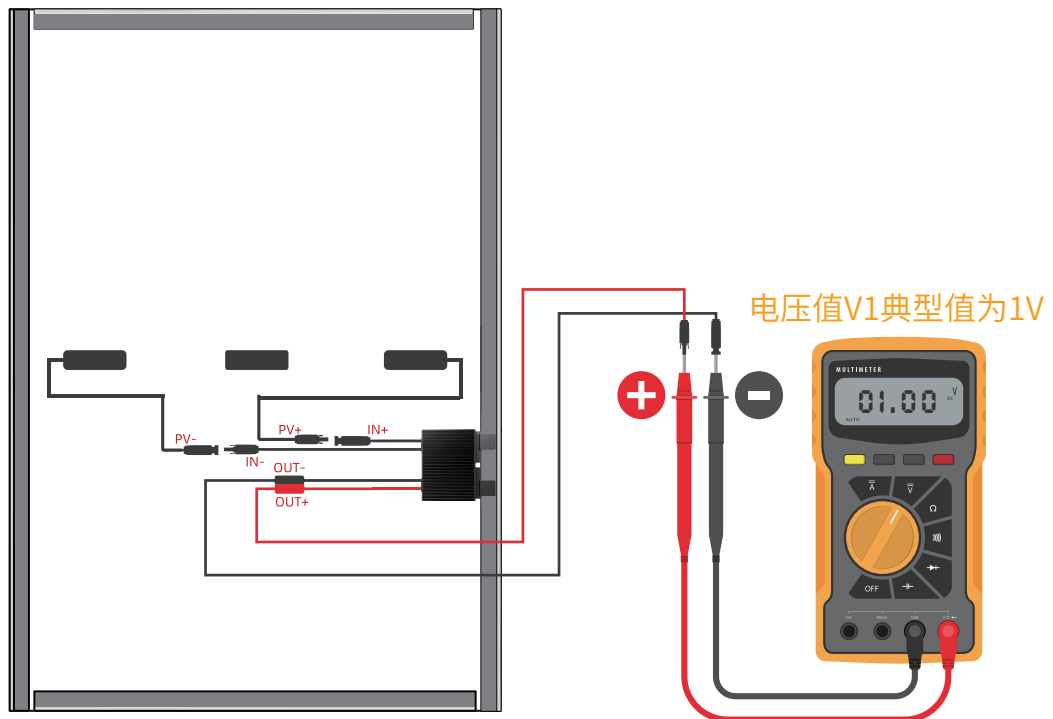

电压值	原因	处理建议
$0.9V \leq V1 \leq 1.1V$	优化器无异常	—
$V1 > 1.1V$	优化器故障	更换优化器
$V1 < 0.9V$	<ul style="list-style-type: none"> ·光照弱 ·优化器输入未连接 ·优化器接线错误 ·优化器故障 	<ol style="list-style-type: none"> 1. 在光照充足时测量电压。 2. 连接优化器输入线缆 3. 修正优化器线缆连接, 将优化器输入线缆连接光伏组件输出 4. 如果电压依然异常, 需更换优化器
$V1 \approx -1V$	表笔接反	表笔正负交换

3. 确认优化器及输入线缆连接无异常后, 连接优化器输出线缆。在光照充足时, 测量光伏组串电压。

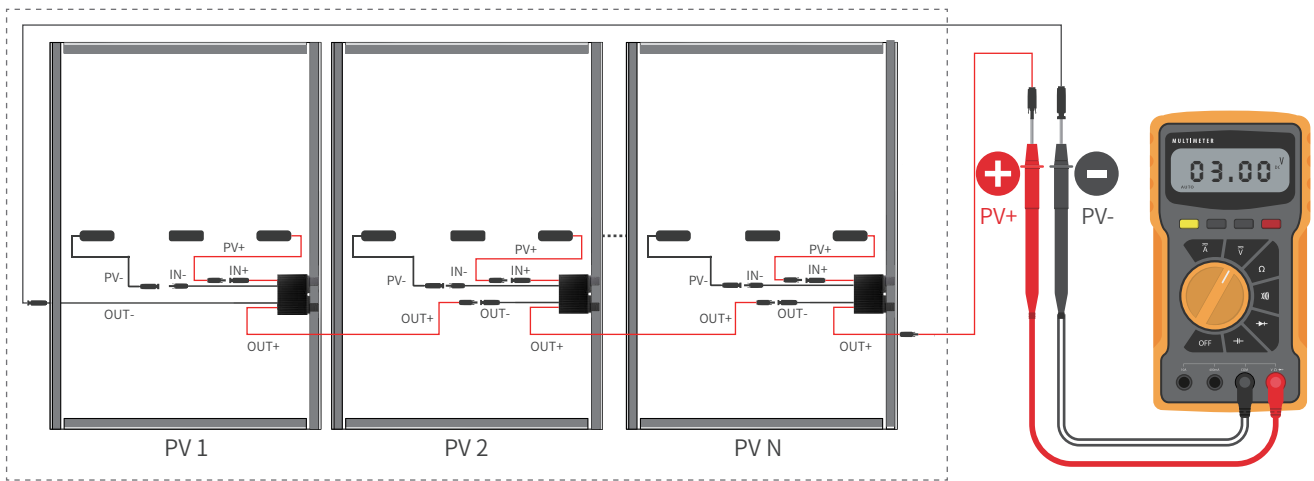

光伏组串

电压值	原因	处理建议
组串电压为0	<ul style="list-style-type: none"> ·光伏组串中存在断路 ·线缆非同一路组串 	<ol style="list-style-type: none"> 1. 排查组串是否存在断路故障 2. 正确编组组串线缆
组串电压为负	<ul style="list-style-type: none"> ·表笔接反 ·线缆标签标识错误 	<ol style="list-style-type: none"> 1. 表笔正负交换 2. 正确制作线缆标签
组串电压小于优化器个数	<ul style="list-style-type: none"> ·部分优化器输入漏接 ·部分优化器输出漏接 ·部分优化器输出反接 	排查组件及组串线缆接线是否正确
组串电压大于优化器个数	<ul style="list-style-type: none"> ·组串中实际优化器数量大于预期数量 ·光伏板未接优化器, 直接接入组串 	<ol style="list-style-type: none"> 1. 检查组串中优化器数量是否正确 2. 排查组件及组串线缆接线是否正确

4 安装GT并将组串连接逆变器

1. 将GT安装到逆变器附近。
2. 将最后一个优化器的OUT+连接到逆变器的PV+。
3. 将第一个优化器的OUT-连接GT (如下图) 再连接到逆变器的PV-。
4. 确认连接无误后GT连接微型断路器再连接到市电。

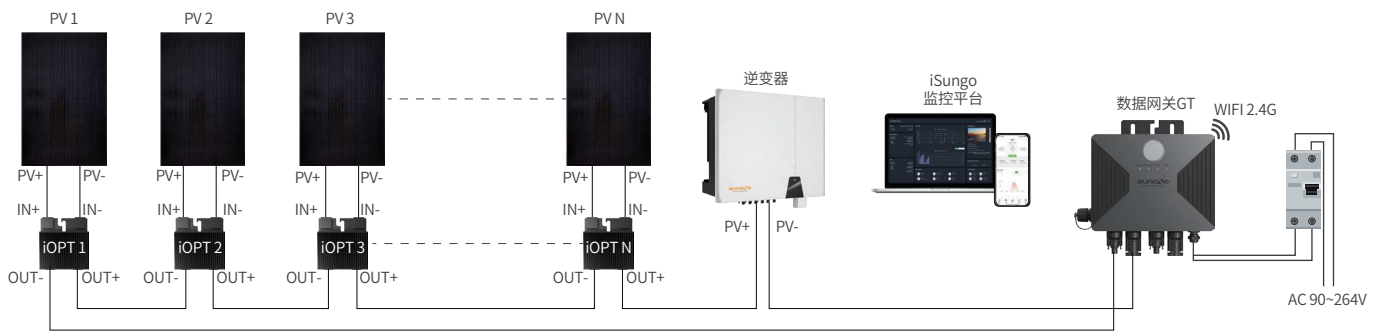

智能优化器连接示意图

- GT本身具有IP67防水, 可以不使用配电柜, AC输入线使用L16-2防水连接器接入市电。
- 检查结构安装件是否牢固, 所有螺丝是否拧紧。
- 检查所有线缆连接极性是否正确, 连接是否牢固可靠, 确保无短路。

5 系统上电和产品管理

步骤1. 逆变器开机

确认系统连接无误, 逆变器DC开关置于ON档, 逆变器开机。

步骤2. 数据网关供电

将数据网关GT接到AC 90~264V市电电源。Power指示灯绿灯常亮, Running指示灯绿灯常亮, 查看逆变器是否正常工作。

步骤3. GT状态指示

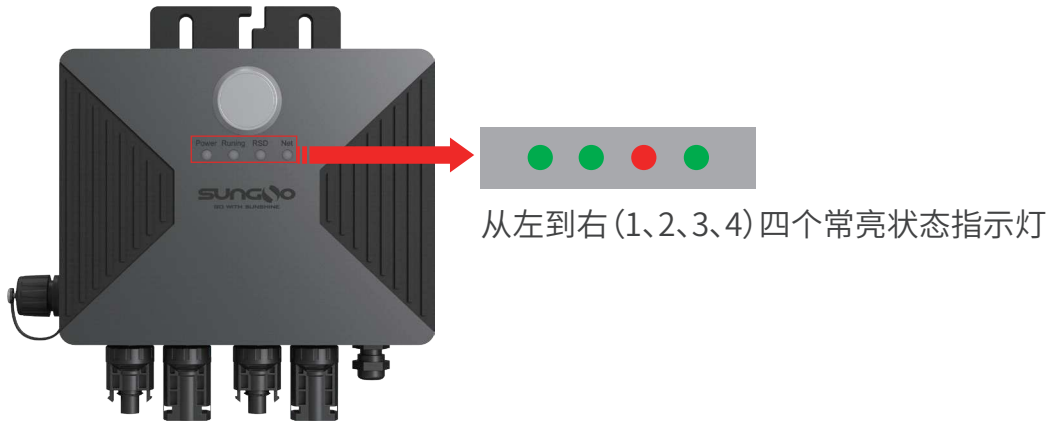

指示灯状态：

1、2、4指示灯状态示意：●表示常亮 ●表示熄灭 ●表示闪烁 3指示灯状态示意：●表示常亮 ●表示熄灭 ●表示闪烁	
四个指示灯都不亮 电路连接错误或者故障	1亮 2灭 3亮 4亮 关断优化器, 网络正常连接
1、2亮 3、4灭 启动优化器, 网络未连接	1亮 2闪烁 3闪烁 4闪烁 自动录入优化器
1、2亮 3灭 4亮 启动优化器, 网络正常连接	1亮 2闪烁 3灭 4灭或亮 自动录入优化器成功
1亮 2灭 3亮 4灭 关断优化器, 网络未连接	1亮 2灭 3闪烁 4灭或亮 自动录入优化器失败

步骤4. GT录入优化器

GT中需要录入所管理的优化器的地址, 否则无法正常通信并上传优化器的数据。录入优化器分别有**自动**和**手动**两种方式, 当现场只有1台GT时可以使用自动录入优化器, 如果现场有多台GT时**必须执行手动**录入优化器。

自动录入优化器 (GT=1个)

按GT中间按钮让Running灯常亮, 让RSD灯熄灭, 5秒后再长按按钮, GT进入自动录入模式, 松开按钮, 指示灯234来回闪烁等待约10分钟Running指示灯闪烁表示自动录入成功, 再次按按钮至Running指示灯常亮, 优化器正常工作。如果指示灯3闪烁代表本次自动录入失败请检查线路后重新执行该步骤, 如果三次都不成功请联系相关技术人员。

手动录入优化器 (GT>1个)

备注:如果使用了自动录入优化器功能,会使现场多台GT中各自管理的优化器重复而产生冲突,只需重新执行手动录入优化器的操作即可。(手动录入优化器是为了将现场的优化器录入到不同的GT中)

一、流程

推荐应用流程:

- 1.首先将GT上电
- 2.采用USB转RS485线,连接GT和电脑
- 3.选择对应的串口
- 4.读取MAC Addr和Version,如果正常显示,代表当前连接正常,否则检查线缆是否正确连接
- 5.录入iOPT编码到List列表,然后点击Write写入GT;录入方式方式有以下两种
 - ①通过Import按钮,识别选择的图片进行导入
 - ②通过键盘手工录入编号,注意每个编号间采用英文逗号进行分割
- 6.通过To Monitor,进行优化器当前状态监控

二、接线

使用USB转RS485,将GT与电脑连接,连接示意如下图

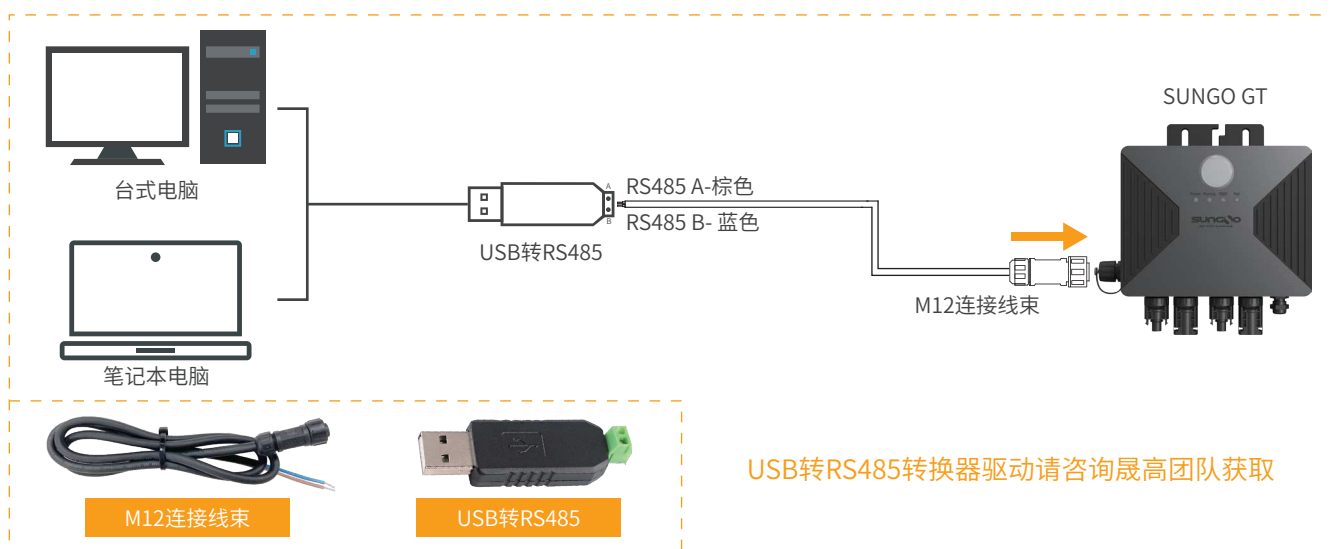

接线示意图

三、说明

1.选择对应的串口

成功后,显示绿圆圈,如下图

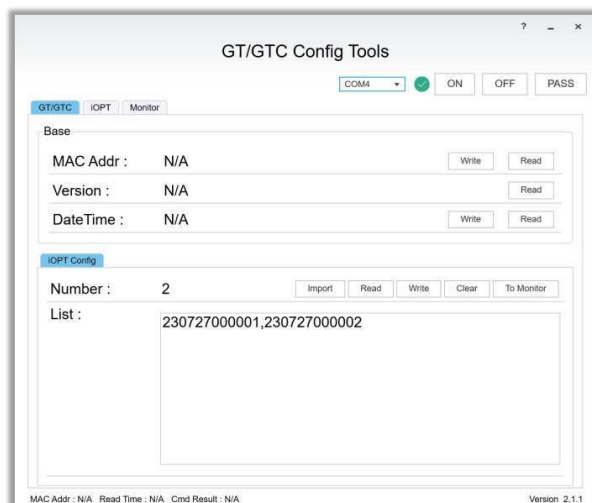
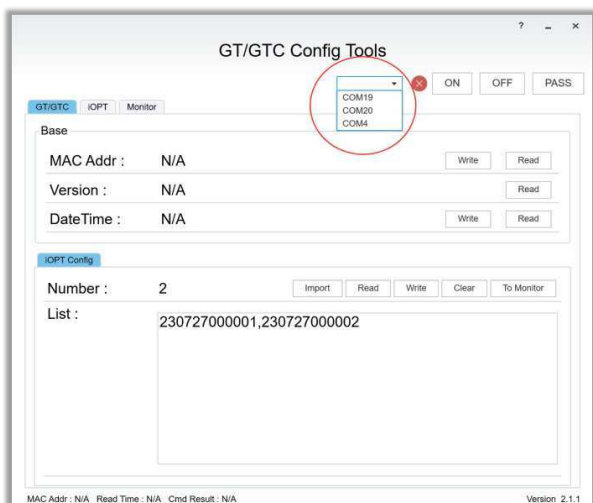

2.GT功能说明

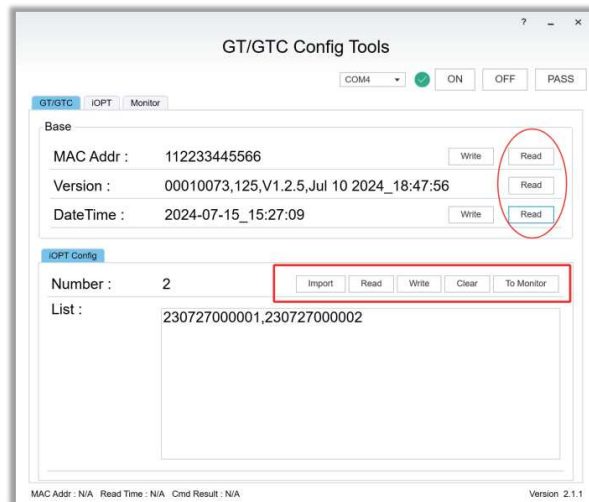

①MAC Addr:

点击Read, 读取GT的地址, 点击Write将左侧输入框内的地址写入GT

②Version

点击Read, 读取GT的软件版本号

③DateTime

点击Read, 读取GT的时间, 点击Write将系统时间写入GT

④iOPT Config – Import

点击Import, 通过图片导入iOPT编码, 如下图

点击Import, 将识别到的编码, 导入List框中

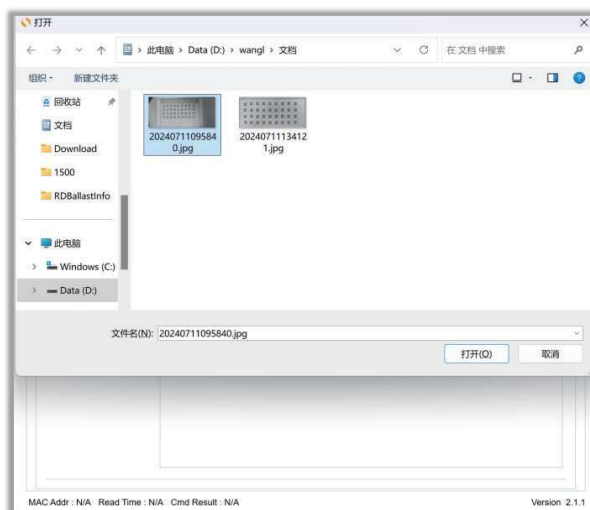

⑤iOPT Config – Read

点击Read, 读取当前GT配置的iOPT列表

⑥iOPT Config – Write

点击Write, 将List中的iOPT列表, 写入GT

⑦iOPT Config – Clear

点击Clear, 将GT中的iOPT都删除

⑧iOPT Config – To Monitor

点击Monitor, 将List列表的iOPT, 放到Monitor页面进行展示

3. 读取单台iOPT工作参数功能说明

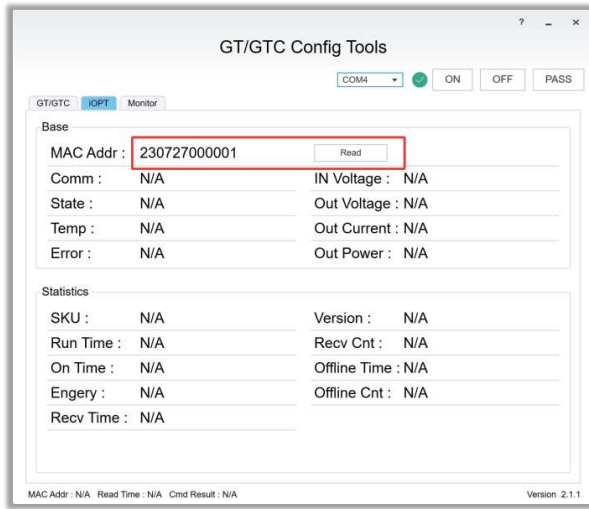

输入需要读取的iOPT编号, 点击Read, 读取其当前状态

Comm: 通讯状态, Online代表在线, Offline代表离线

State: 当前状态, ON工作, OFF关闭

Temp: 当前温度, 摄氏度

Error: 当前故障, Normal代表正常

IN Voltage: 输入电压

Out Voltage: 输出电压

Out Current: 输出电流

Out Power: 输出功率

SKU: 产品型号

Run Time: 运行时间

On Time: 工作时间

Engery: 发电量

Recv Time: 接收时间

4. Monitor功能说明

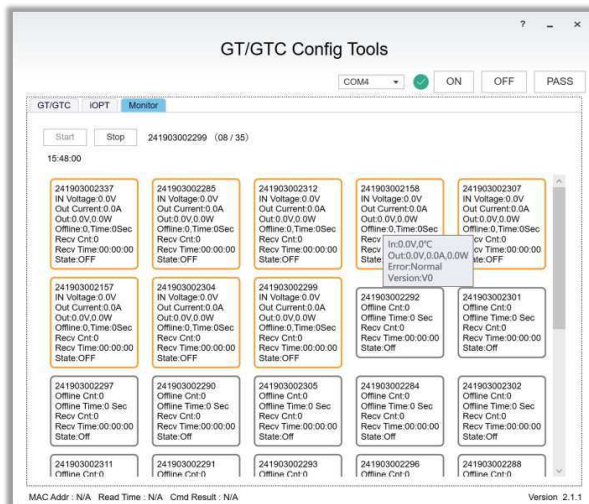

点击Start, 启动监控, 软件将定时刷新List中iOPT的状态。

6.1 GT配网(APP1.0 使用说明)

步骤1. 下载APP并注册账号



扫描二维码下载
iSungo APP



打开APP注册账号

步骤2. 创建电站



点击右上角创建电站

步骤3. 填写电站信息



步骤4. 扫码采集数据网关



WIFI Serial Number:
XXXXXXXXXXXXXXXXXX

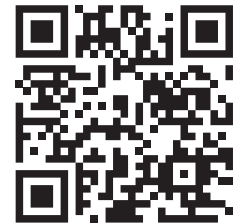

GT左侧二维码示例

点击电站右侧箭头, 下拉点击添加采集器, 扫描数据网关GT左侧面的WIFI序列号二维码。

步骤5. GT WIFI 配网

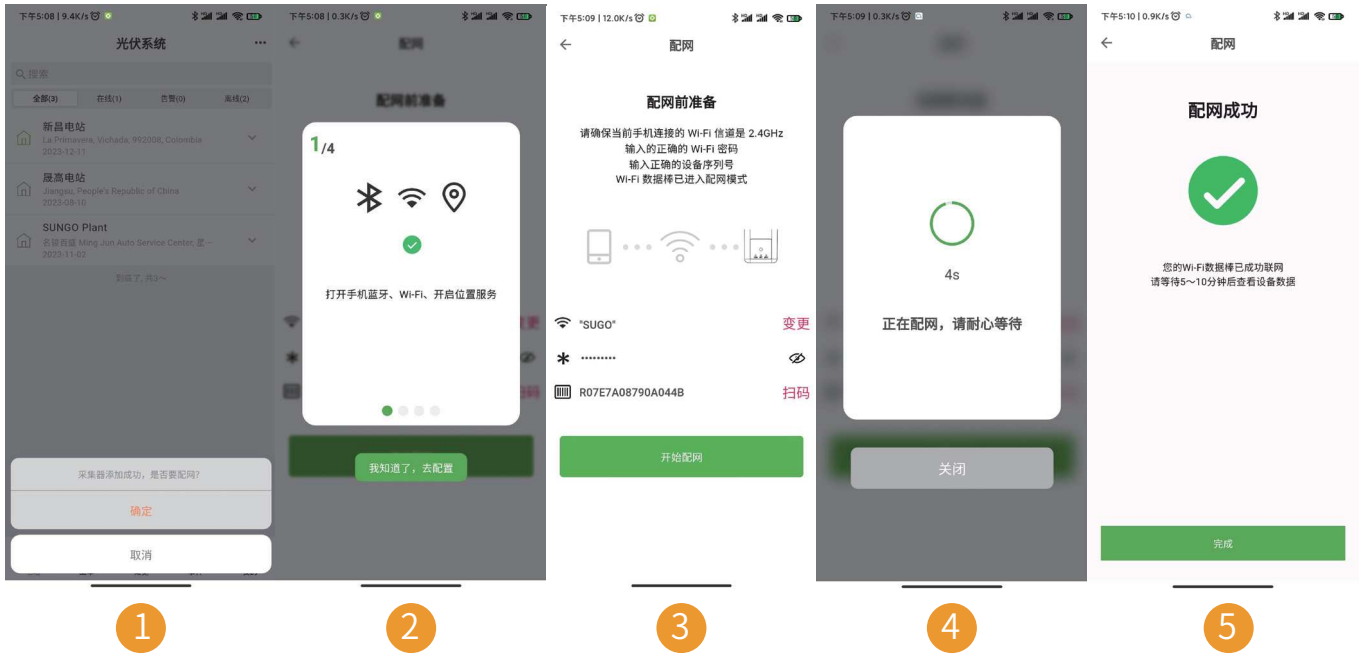

按照指示流程操作, 显示配网成功即可。

步骤6. 优化器状态查看



配网成功后, 点击电站项目右侧箭头直到出现优化控制器, 然后点击优化控制器, 再点击优化器编码, 查看优化器详情。

步骤7. 查看电站状态



点击APP**概览**,再打开页面右上角下拉菜单,点击**布局**查看状态。

点击布局后,电站状态如下图几种状态显示。

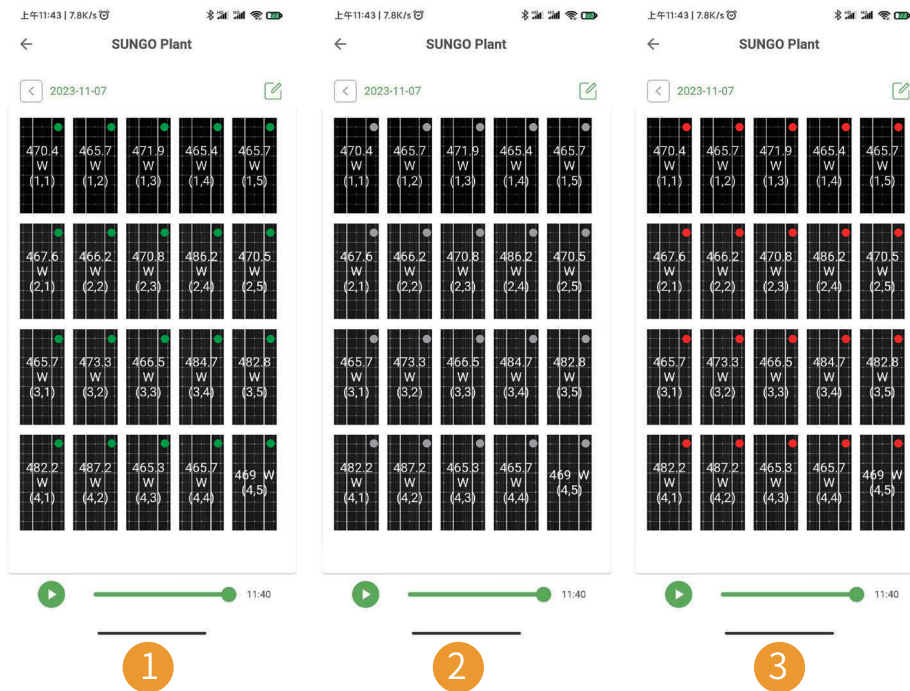

状态	说明
如图1-右上角绿色圆圈	优化器运行正常
如图2-右上角灰色圆圈	优化器离线,请检查SN和位置信息是否正确,然后重新搜索设备
如图3-右上角红色圆圈	优化器故障,需更换优化器

6.2 GT配网(APP2.0 使用说明)

步骤1. 下载APP并注册账号



iSungo-Android



iSungo-ios

扫描二维码下载
iSungo APP



打开APP注册账号

步骤2. 创建电站

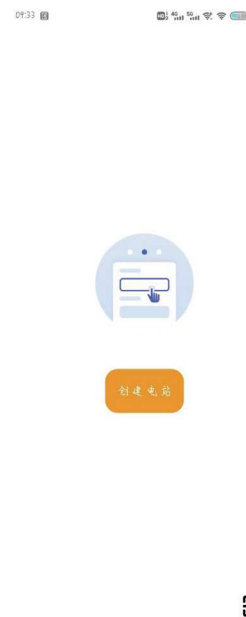

点击创建电站

步骤3. 填写电站信息



按照自己的电站信息填写即可

步骤4. 扫码采集数据网关



WIFI Serial Number:
XXXXXXXXXXXXXXXXXX



GT左侧二维码示例

点击右上角下拉菜单, 点击“添加采集器”, 扫描数据网关GT左侧面的WIFI序列号二维码

步骤5. GT WIFI 配网

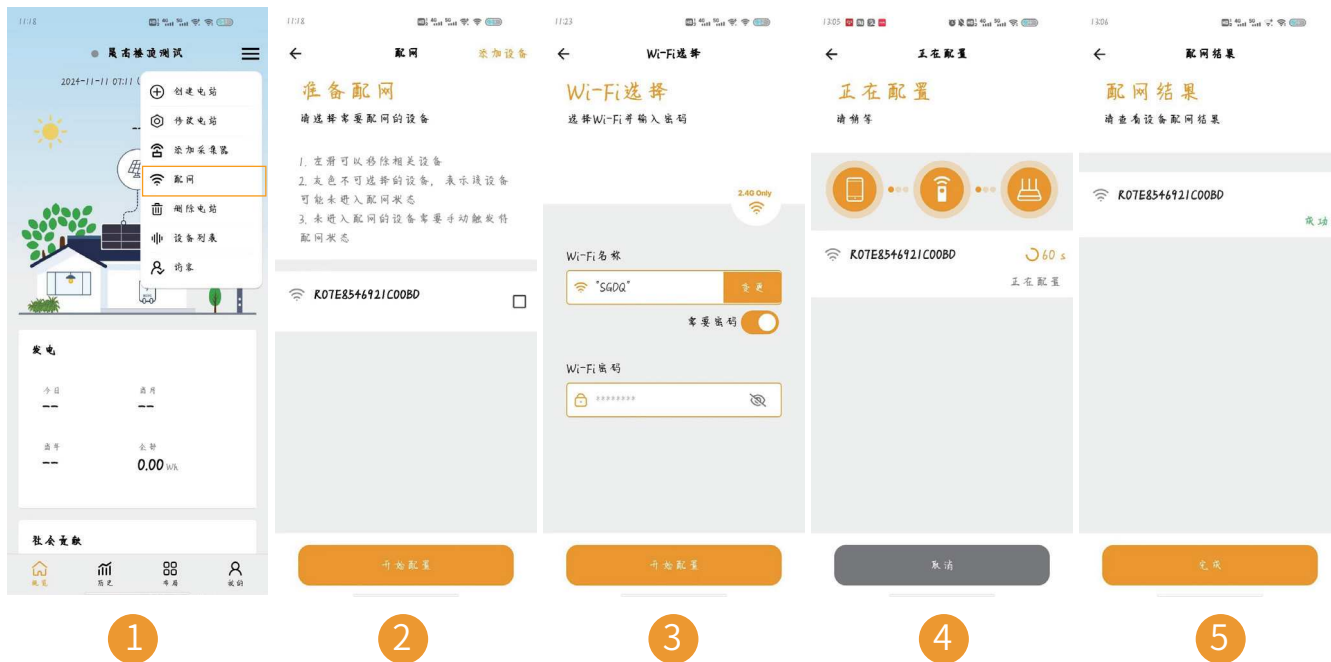

先点击“概览”页面右上角下拉菜单,点击“配网”,按照指示流程操作,显示配网成功即可

步骤6. 优化器详情

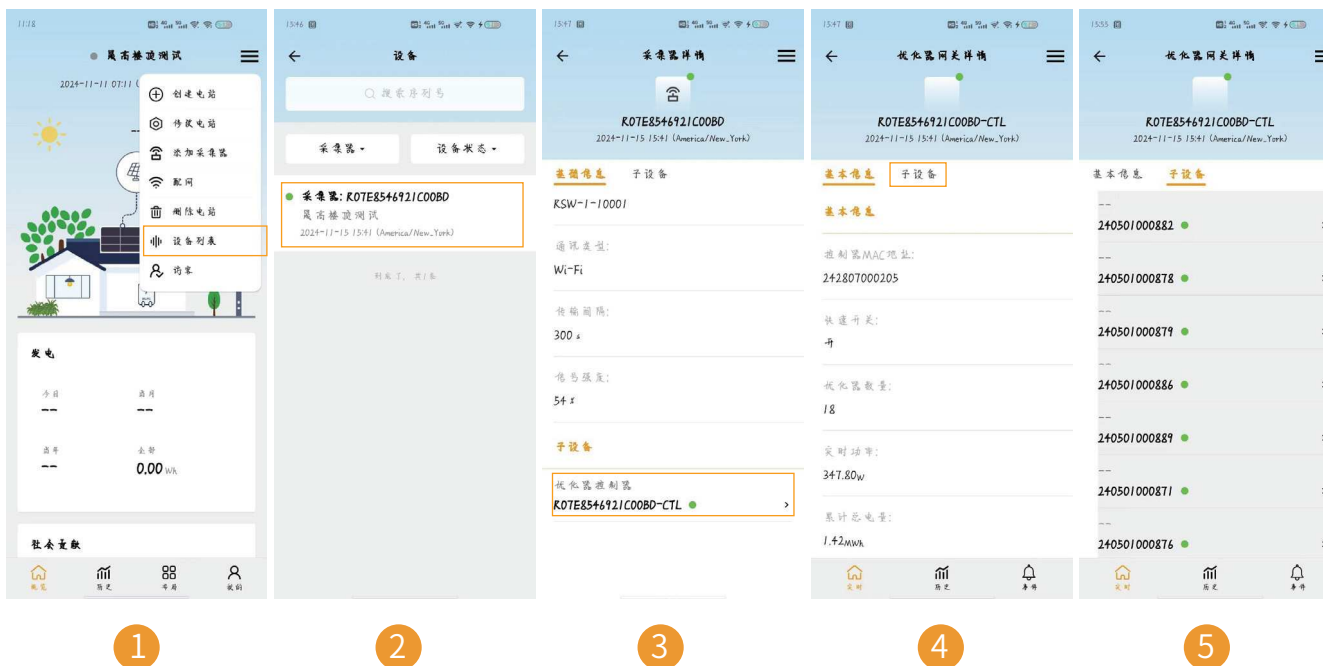

- 1.点击“概览”页面右上角的下拉菜单,然后点击“设备列表”
- 2.点击“采集器”栏目即可进入采集器详情页面
- 3.点击“采集器详情”下方的“优化器控制器”即可进入“优化器网关详情”页面
- 4.点击“子设备”就可以看到优化器序列号
- 5.点击优化器序列号右侧箭头就可以进入“优化器详情”页面

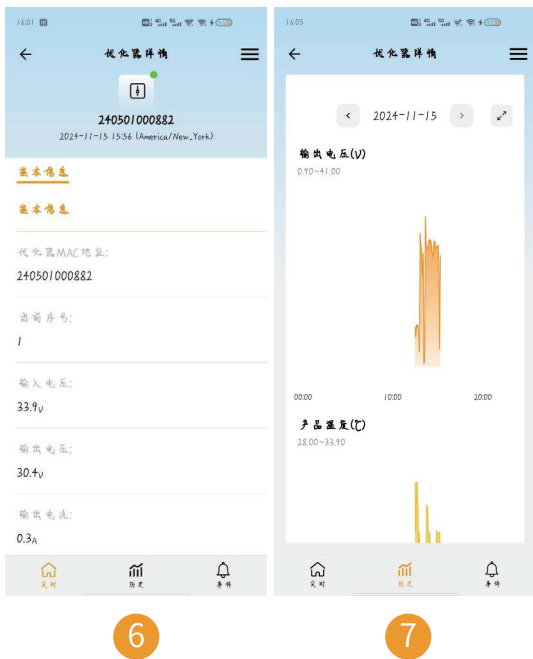

6. “优化器详情”页面显示设备信息

7. 点击下方“历史”图标就可以看到“优化器详情”的图表显示（显示输入电压，输出电压，温度，输出电流和输出功率）

步骤7. 查看电站状态

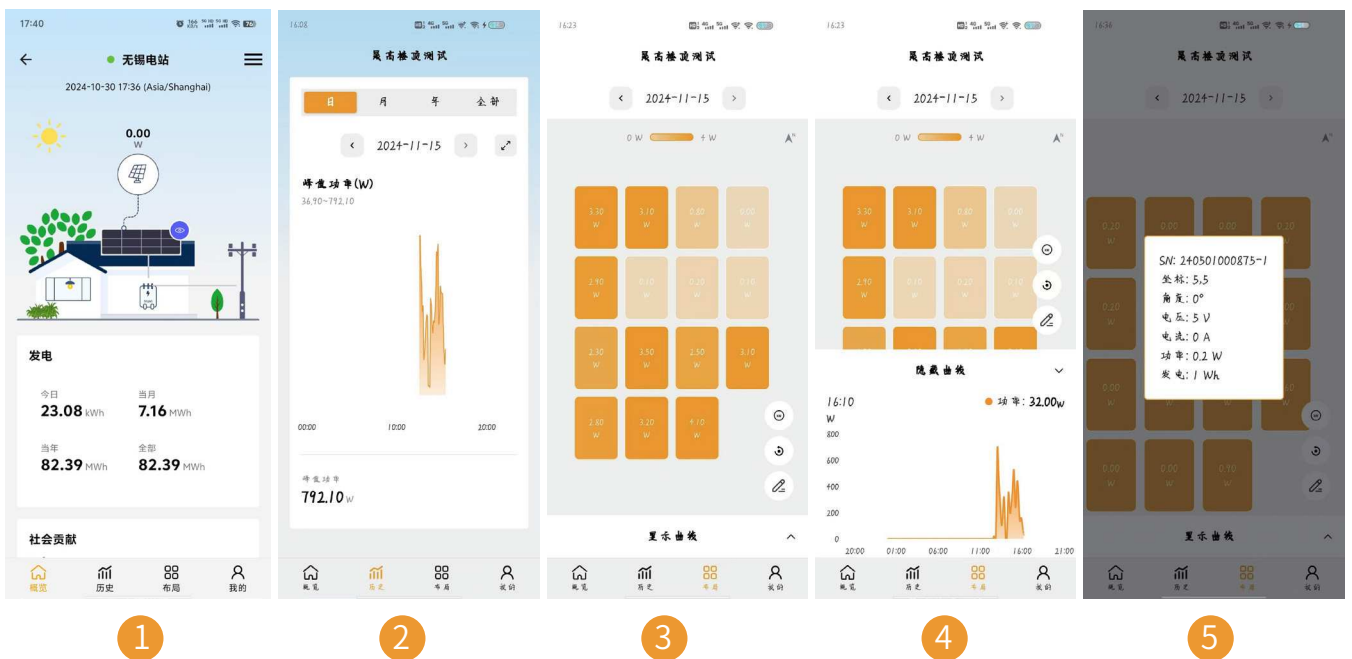

1. 返回“概览”页面可以看到电站发电的基本信息

2. 点击APP“概览”右侧的“历史”可以看到电站的峰值功率

3. 点击APP“历史”右侧的“布局”可以看到光伏组件的状态

4. 点击“显示曲线”可以看到光伏组件的功率曲线

5. 长按“光伏组件图形”可以显示组件的详细信息

步骤8. 布局修改

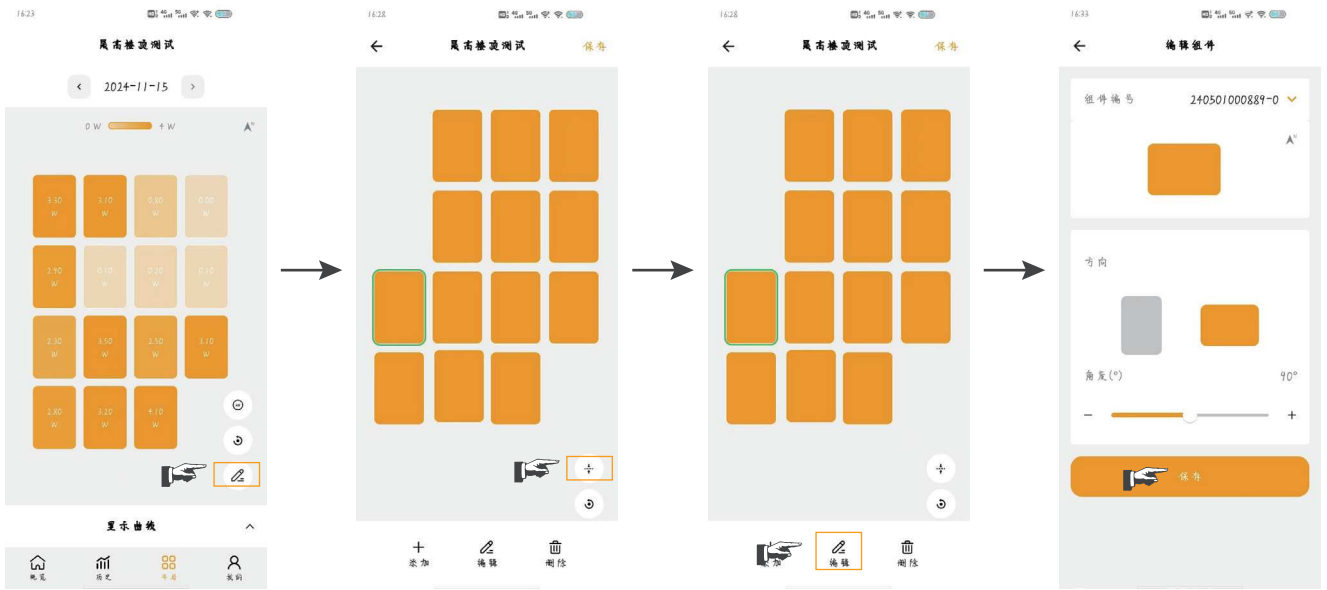

点击此处小图标
可以修改布局

点击此处小图标有
虚线网格方便布局

点击编辑

可以修改组件角度，
完成后保存即可

其它功能

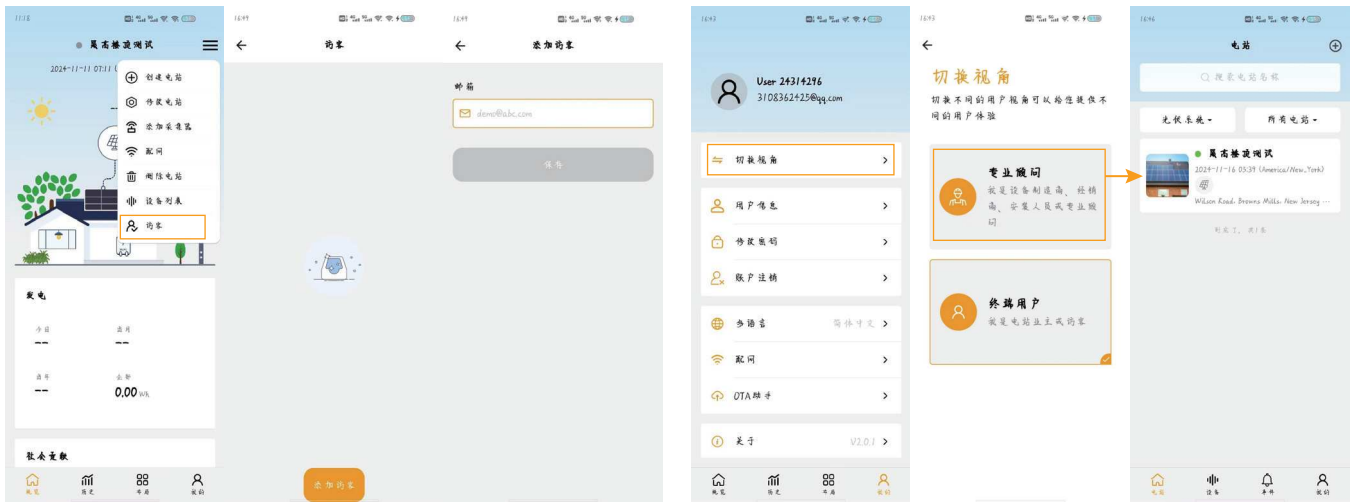

添加访客邮箱

切换视角，专业顾问和终端用户，
以上步骤都是基于终端用户进行操作

全球总部

晟高能源科技(江苏)有限公司

地址:江苏省苏州市工业园区苏虹西路179号1层01单元

优化器&储能制造中心

康晟佳智慧能源(浙江)有限公司

地址:浙江省绍兴市新昌县澄潭街道兴梅大道69号小微产业园3#楼

日本公司

SungoEnergy株式会社

地址:東京都武蔵野市関前四丁目16番5-206号

荷兰公司

SUNGO Energy Technology B.V.

地址:Hoofdweg-Noord 9T, 2913LB Nieuwerkerk aan den IJssel, The Netherlands

英国公司

地址:60 Windsor Avenue, London SW19 2RR, United Kingdom

美国公司

SUNGO ENERGY TECHNOLOGY INC.

地址:5900 Balcones Drive,STE 100 Austin TX 78731

网址: www.sungoess.com

邮箱: sales@sungoess.com

电话: +86 (0)512 6512 2036

售后邮箱: after-sales@sungoess.com

版权所有©晟高能源科技(江苏)有限公司,保留一切权利。本文提及的所有其他商标均为其各自所有者的商标。
本文档信息仅供参考,不构成任何要约和承诺,晟高能源科技可能不经通知修改上述信息,恕不另行通知。



微信公众号



视频号



抖音