



江苏佑诚至信机电设备有限公司

Jiangsu Youcheng Zhixin Electromechanical Equipment Co., Ltd

公司/产品宣传手册

Corporate/Product Brochure

中国·江苏

CONTENTS

目录

01

公司介绍

About Us

02

产品介绍

Our Products

03

发展规划

Development planning

04

联系方式

Contact Us



1

PART 1

公司介绍 AboutUs

公司简介、发展历程、企业文化、企业架构

Our Profile, Development history, Culture & Enterprise Structure

Jiangsu Youcheng Zhixin Electromechanical Equipment Co., Ltd





1.1

PART 1.1

公司简介 Our Profile

简介、车间设备、资质证书、样品展厅

Brief, Equipment, Certificates & Showroom

Jiangsu Youcheng Zhixin Electromechanical Equipment Co., Ltd



公司简介

Our Profile - Brief

江苏佑诚至信机电设备有限公司

Jiangsu Youcheng Zhixin Electromechanical Equipment Co., Ltd



专注五金设备领域10余年

以佑诚之名为全球自动化设备企业提供优质产品和服务

Focused on the field of hardware equipment for over 20 years

Providing high-quality products and services to global automation equipment enterprises under the name of Youcheng

- 江苏佑诚至信机电设备有限公司（简称“佑诚至信”）
- 成立于**2013年**，现位于江苏省昆山市。是一家集研发、设计、生产和销售为一体的企业。主要产品有：**储气罐、真空泵、电机、风机、气动元件、真空系统五金制品、电子材料**等。具体的应用领域主要有以下几方面：在电力行业、石油化工行业、食品行业、CNC加工、制药行业、印刷行业、航天行业、塑料工业、实验室医疗器械等。
- 公司一贯坚持“客户至上、以人文本、品质第一、价值第一”的宗旨，凭借着高质量的产品，良好的信誉，优质的服务，产品畅销全国以及远销全球155个国家。
- 竭诚与国内外商家双赢合作，共同发展，共创辉煌！
- Jiangsu Youcheng Zhixin Electromechanical Equipment Co., Ltd. (referred to as "Youcheng Zhixin")
- Founded in 2013, it is now located in Kunshan, Jiangsu Province. It is an enterprise that integrates research and development, design, production, and sales. The main products include: air storage tanks, vacuum pumps, motors, fans, pneumatic components, vacuum system hardware products, electronic materials, etc. The specific application areas mainly include the following: in the power industry, petrochemical industry, food industry, CNC processing, pharmaceutical industry, printing industry, aerospace industry, plastic industry, laboratory medical equipment, etc.
- The company has always adhered to the principle of "customer first, people-oriented, quality first, and value first". With high-quality products, good reputation, and high-quality service, the products are best-selling nationwide and exported to 155 countries around the world.
- Sincerely cooperate with domestic and foreign merchants for win-win cooperation, common development, and create brilliance together!

公司简介——车间设备

Our Profile - Equipment

江苏佑诚至信机电设备有限公司

Jiangsu Youcheng Zhixin Electromechanical Equipment Co., Ltd



公司简介——样品展厅

Our Profile - Sample Showroom

江苏佑诚至信机电设备有限公司

Jiangsu Youcheng Zhixin Electromechanical Equipment Co., Ltd

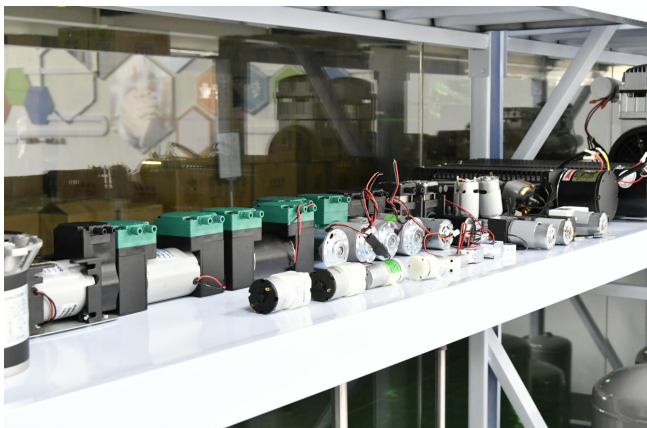



1.2

PART 1.2

发展历程 Our Development

发展历程及企业概况

Our Development & Now

Jiangsu Youcheng Zhixin Electromechanical Equipment Co., Ltd



公司成立 Incorporation

江苏佑诚至信机电设备有限公司于2013年03月07日成立

Jiangsu Youcheng Zhixin Electromechanical Equipment Co., Ltd. was established on March 7, 2013.

业务发展 Business Development

在国内销售平台：储气罐、真空泵、风机、电机、气动元件、空压机、五金制品、电子材料等，取得较好的成果

We have achieved good results in domestic sales platforms such as gas storage tanks, vacuum pumps, fans, motors, pneumatic components, air compressors, hardware products, electronic materials, etc.

全面开拓 Comprehensive development

快速发展的一个阶段，扩建工厂，规模扩大，由大部分外发加工转为自主生产

A stage of rapid development, with expansion of factories and expansion of scale, shifting from most outsourced processing to independent production.

2017

可持续发展 Sustainable development

进入2023年公司立足专业技术创新，把客户满意度做到极致。公司力图成为客户事业重要的参与者、友好伙伴，不断开发新产品，新服务，积极推进企业可持续发展

Entering 2023, the company will focus on professional and technological innovation, achieving the ultimate in customer satisfaction. The company strives to become an important participant and friendly partner in the customer business, continuously developing new products and services, and actively promoting sustainable development of the enterprise

2013

2015

2020

2023

国际投资 International investment

企业进一步发展起来后，着眼于走国际化道路，开拓国外市场，抓住了大量外销商机；同时也提高了在国际市场上的竞争力和影响力

After the enterprise further developed, it focused on taking the path of internationalization, exploring foreign markets, and seizing a large number of export business opportunities; At the same time, it has also improved its competitiveness and influence in the international market.

佑诚至信的产品出口全球155个国家和地区

目前公司拥有2家自有工厂

Youcheng Zhixin's products are exported to 155 countries and regions worldwide

Currently, the company has two own factories



2家

- 出口全球155个国家和地区，包括欧洲、北美、南美、东南亚等国家；
- Exported to 155 countries and regions worldwide, including Europe, North America, South America, Southeast Asia, and other countries;

- 江苏苏飞特机械设备有限公司
- 江西光丰机械设备有限公司
- Jiangsu Sufeite Machinery Equipment Co., Ltd
- Jiangxi Guangfeng Machinery Equipment Co., Ltd



1.3

PART 1.3

企业文化 Our Culture

企业使命、企业愿景、企业价值观

Corporate Mission, Wish & Value

Jiangsu Youcheng Zhixin Electromechanical Equipment Co., Ltd



以佑诚之名为全球
自动化设备企业提供
优质产品和服务

Providing high-quality
products and services to
global automation equipment
enterprises under the name of
Youcheng

使命
mission

客户至上 以人为本
品质第一 价值第一

Customer first, people-
oriented, quality first, and
value first

价值观
values

创优质品牌
铸一流企业

Creating high-quality brands
and creating first-class
enterprises

愿景
Vision



1.4

PART 1.4

企业架构 Enterprise Structure

内贸部、外贸部、工厂、仓储、财务部...

Domestic trade department, overseas trade department, factory, finance department...

Jiangsu Youcheng Zhixin Electromechanical Equipment Co., Ltd





佑诚至信董事长：苏检华

Chairman of Youcheng Zhixin: Jianhua Su

人生格言：攀登，永不停止

Life motto: Challenge yourself, have the courage to climb, and never stop





佑诚至信总经理：李娜

General Manager of Youcheng Zhixin: Na Li

人生格言：成功属于敢于自我超越的人。

Motto: Success belongs to those who are self - transcendent.

企业架构

Our Structure

江苏佑诚至信机电设备有限公司

Jiangsu Youcheng Zhixin Electromechanical Equipment Co., Ltd

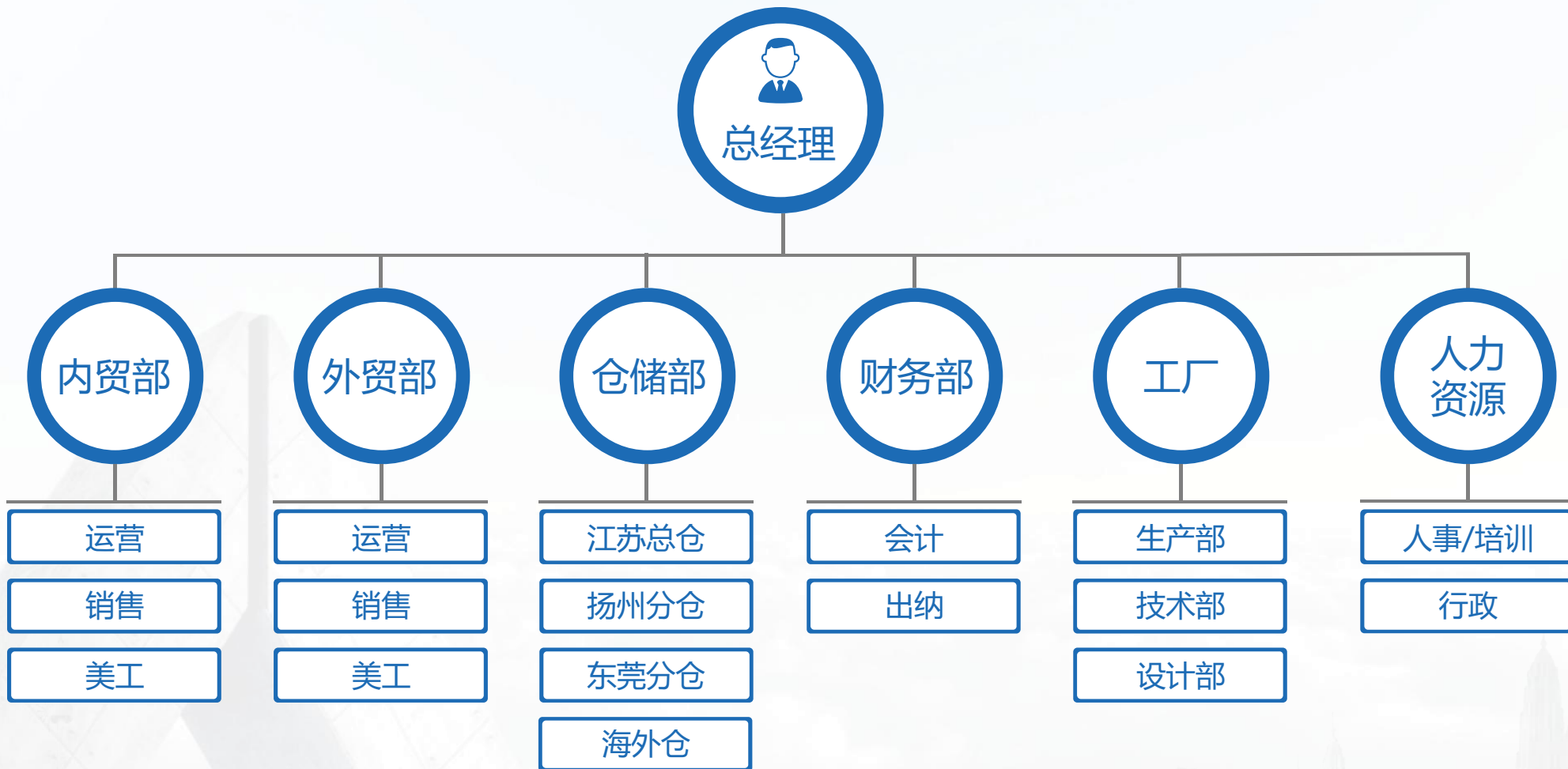

2

PART 2

我们的产品 Our Products

储气罐、电机、风机、真空泵、真空系统、气动元件以及五金设备...

Air tanks, Motors, Fans, Vacuum pumps, Vacuum systems, Pneumatic components, and Hardware equipment

Jiangsu Youcheng Zhixin Electromechanical Equipment Co., Ltd

我们的产品——储气罐

Our Products - Air Tank

江苏佑诚至信机电设备有限公司

Jiangsu Youcheng Zhixin Electromechanical Equipment Co., Ltd



• 碳钢储气罐 Carbon steel air storage tank



• 304不锈钢镜面储气罐 304 stainless steel mirror air storage tank



• 304不锈钢磨砂储气罐 304 stainless steel frosted air storage tank



• 铝合金储气罐 Aluminum alloy air storage tank



我们的产品——电机

Our Products - electrical machinery

江苏佑诚至信机电设备有限公司

Jiangsu Youcheng Zhixin Electromechanical Equipment Co., Ltd



• 小功率长轴电机 Small power long shaft motor



• 大功率长轴电机 High power long shaft motor



• 隔热款长轴电机 Insulated long shaft motor



• 防爆款长轴电机 Explosion proof long shaft motor



我们的产品——风机

Our Products - fan

江苏佑诚至信机电设备有限公司

Jiangsu Youcheng Zhixin Electromechanical Equipment Co., Ltd



• 普通款离心风机 Ordinary centrifugal fan

• 隔热款离心风机 Insulated centrifugal fan

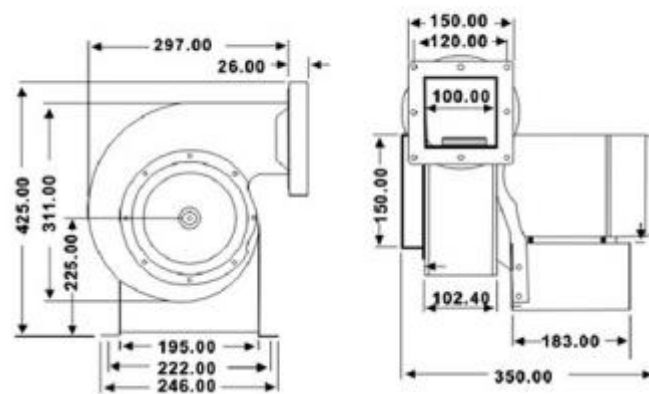
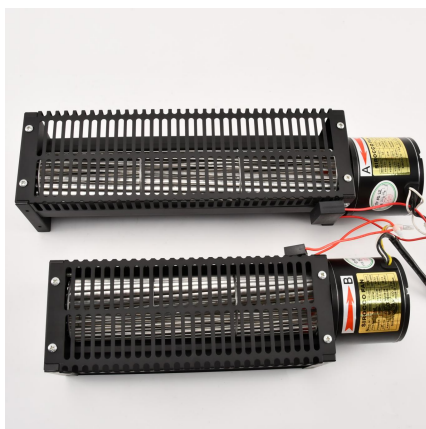

• 横流风机 Cross flow fan

我们的产品——真空泵

Our Products - vacuum pump

江苏佑诚至信机电设备有限公司

Jiangsu Youcheng Zhixin Electromechanical Equipment Co., Ltd

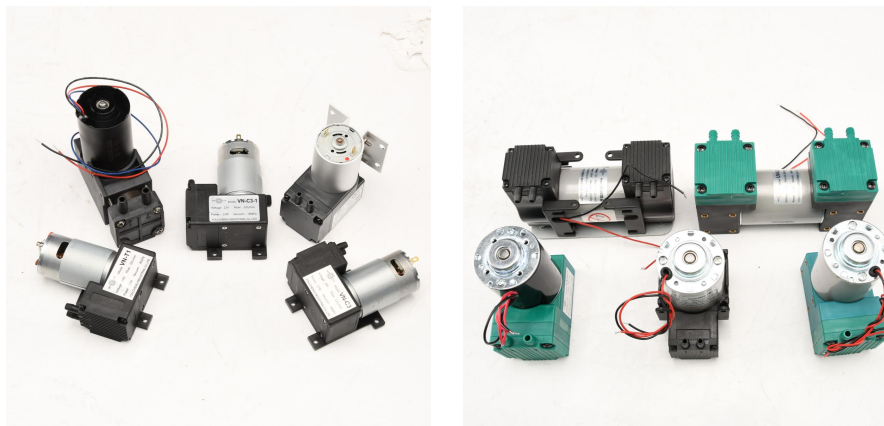

• 直流真空泵 DC vacuum pump



• 无油真空泵 Oil free vacuum pump



• 旋片真空泵 Vane Vacuum Pump



• 隔膜真空泵 Diaphragm Vacuum Pump

我们的产品——真空系统

Our Products - vacuum system

江苏佑诚至信机电设备有限公司

Jiangsu Youcheng Zhixin Electromechanical Equipment Co., Ltd



• 无油真空泵站 Oil free vacuum pump station

• 旋片真空泵站 Rotary vane vacuum pump station



• 水环式真空泵系统 Water ring vacuum pump system

• 自动真空排水系统 Automatic vacuum drainage system

我们的产品——消泡桶

Our Products - Defoaming bucket

江苏佑诚至信机电设备有限公司

Jiangsu Youcheng Zhixin Electromechanical Equipment Co., Ltd



• 不锈钢消泡桶 Stainless steel defoaming bucket

• 压力桶 Pressure bucket



• 透明盖消泡桶 Transparent lid defoaming bucket

我们的产品——增压泵

Our Products - Booster pump

江苏佑诚至信机电设备有限公司

Jiangsu Youcheng Zhixin Electromechanical Equipment Co., Ltd



• 增压阀 Boost valve



• 增压阀 + 储气罐 Booster valve+air tank



• 增压阀 + 增压罐 + 二联件 Booster valve+air tank+dual piece



• 四维科技增压阀 4D Technology Booster Valve

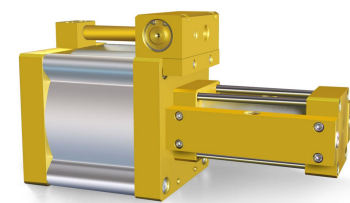

我们的产品——风轮/风叶

Our Products - Wind wheel/blade

江苏佑诚至信机电设备有限公司

Jiangsu Youcheng Zhixin Electromechanical Equipment Co., Ltd



• 镀锌风轮 Galvanized wind turbine

• 镀锌风叶 Galvanized fan blades



• 304不锈钢风轮 304 stainless steel wind turbine



3

PART 3

发展规划 Development planning

发展计划、创新战略、品牌战略、产品战略.....

Development plan, innovation strategy, brand strategy, product strategy

Jiangsu Youcheng Zhixin Electromechanical Equipment Co., Ltd



发展计划 Development planning

未来3-5年内公司将继续推进“引进高端人才+加强产品创新和集成+推动成果产业化+抢占国际市场”的战略，以实现跨越式快速发展！抓住机遇，向外拓展，向内挖潜，扩大品牌美誉，实现跨越式发展。

In the next 3-5 years, the company will continue to promote the strategy of "introducing high-end talents, strengthening product innovation and integration, promoting industrialization of achievements, and seizing the international market" to achieve rapid development by leaps and bounds! Seize opportunities, expand outward, tap potential inward, expand brand reputation, and achieve leapfrog development.

中长期发展规划具体目标

Specific goals for medium and long-term development planning

- | | |
|------------------------------|------------------------------|
| (一) 创新战略 Innovation Strategy | (二) 品牌战略 Brand Strategy |
| (三) 产品战略 Product Strategy | (四) 销售战略 Sales Strategy |
| (五) 人才战略 Talent Strategy | (六) 管理战略 Management Strategy |

(一) 创新战略 Innovation strategy

加大研发投入

- 从组织体系、资金投入和人才开发等方面，加强企业技术中心建设，以拓品为核心，提高企业产品创新能力。
- 产品研发成为企业发展战略和发展规划的研究中心，信息化的集成中心，市场调研和开拓中心，产学研联合中心，新产品、新技术、新设备、新工艺、新材料的研发中心，知识产权创建和管理中心。
- 实施知识产权战略，提升知识产权的创造、应用、保护和管理能力。
- 积极申报专利，积极申报国家、省、市级科技成果奖，树立通过自主创新，创建核心技术自主知识产权的意识。
- Strengthen the construction of enterprise technology centers from the aspects of organizational system, capital investment, and talent development, with expanding products as the core, and improve the enterprise's product innovation ability.
- Product R&D has become a research center for enterprise development strategy and development planning, an information integration center, a market research and development center, an industry university research United Center, a research and development center for new products, new technologies, new equipment, new processes, and new materials, and a center for intellectual property creation and management.
- Implement an intellectual property strategy to enhance the ability to create, apply, protect, and manage intellectual property.
- Actively apply for patents, actively apply for national, provincial, and municipal scientific and technological achievements awards, and establish the awareness of creating independent intellectual property rights for core technologies through independent innovation.



(二) 品牌战略 Branding

品牌推广



- 加快从做产业做销售做营销做品牌的发展。实现从质量战略到品牌战略的转变。
- 通过企业内部整合和全员培训，使品牌建设的内容渗透到企业经营管理、产品研发生产、销售和营销的各个环节，品牌建设的理念为全体员工认同并身体力行。
- 通过各项品牌识别元素、直销活动、展会、网页、专业杂志、企业资料、大型推介活动等形式引进品牌的传播，使用户认知企业、认知品牌、认知产品。
- 积极慎重地申报国家和各级政府认可的、不以盈利为目的的评价和奖励项目，提高企业和企业品牌的知名度和公信力。
- Accelerate the development of industries, sales, marketing, and brands. Realize the transformation from quality strategy to brand strategy.
- Through internal integration and training for all employees, the content of brand building is permeated into all aspects of enterprise management, product research and development, production, sales, and marketing. The concept of brand building is recognized and practiced by all employees.
- Introduce brand communication through various brand identification elements, direct sales activities, exhibitions, web pages, professional magazines, enterprise materials, large-scale promotion activities, etc., to enable users to recognize the enterprise, brand, and products.
- Actively and cautiously apply for evaluation and reward projects recognized by the state and governments at all levels that are not for profit, in order to enhance the visibility and credibility of enterprises and their brands.

(三) 产品战略 Product

开拓市场/研发新品

- 在产品结构方面，公司将进一步丰富产品结构，大力开拓市场。
- 公司将加强新产品研发工作，并不断增强产品设计和产品定制能力，努力生产出更多性价比更高的新产品。
- 在产品制造方面，公司将严控质量，开展质量兴企活动，强化包括生产准备、加工制造、交付与使用全过程的质量控制。
- 通过对全员的培训、全岗位的规范、全员活动的监管、约束、考核，实现全员的质量控制。从而，保证优秀的产品实物质量。
- 在采购方面，公司将执行原材料采购评审制度，保证原材料优质低价输入，并通过与零配件生产企业组成产业战略联盟，缩短产业链，降低运营成本，增强一体化经营能力。
- In terms of product structure, the company will further enrich its product structure and vigorously explore the market.
- The company will strengthen the research and development of new products, continuously enhance product design and customization capabilities, and strive to produce more cost-effective new products.
- In terms of product manufacturing, the company will strictly control quality, carry out quality revitalization activities, and strengthen quality control throughout the entire process, including production preparation, processing and manufacturing, delivery, and use.
- By providing training to all employees, standardizing all positions, and supervising, constraining, and assessing all activities, we can achieve quality control for all employees. Thus, ensuring excellent physical product quality.
- In terms of procurement, the company will implement a raw material procurement review system to ensure high-quality and low-cost input of raw materials, and form an industrial strategic alliance with spare parts production enterprises to shorten the industrial chain, reduce operating costs, and enhance integrated business capabilities.

(四) 销售战略 Sales Strategy

完善销售体系，建设销售团队

完善销售体系，建设销售团队，制订并执行适合市场需求，建立一支有责任心、事业心，积极开拓进取的销售队伍。实现市场结构的根本调整，把市场开拓的重点放在客户上，努力与各大行业的排头兵企业建立战略合作关系，从根本上调整市场结构。

Improve the sales system, build a sales team, formulate and implement a sales team that is suitable for market demand, and establish a responsible, enterprising, and actively pioneering sales team. Realizing fundamental adjustments to the market structure, focusing market development on customers, striving to establish strategic partnerships with leading enterprises in various industries, and fundamentally adjusting the market structure

提升企业整体形象，提高客户满意度

以企业的规模和生产能力，技术创新体系、能力、队伍、投入和成果，员工的素质和凝聚力，厂容厂貌的气质构成的企业整体形象，以优质的产品、良好的服务、合理的性价比、供需关系的和谐亲和，为客户提供无忧虑的产品应用，提高客户的满意度。

The overall image of the enterprise is composed of its scale and production capacity, technological innovation system, capabilities, team, investment and achievements, employee quality and cohesion, and the appearance of the factory. With high-quality products, good services, reasonable cost-effectiveness, and harmonious supply-demand relationships, we provide customers with worry free product applications and improve customer satisfaction.

(五) 人才战略 Talent strategy

加强人才队伍建设



努力形成系统、持续、长中短期兼顾的人力资源管理体系。牢固树立人才是第一资源，加强人才队伍建设是提升企业竞争力的决定因素的观点，把人力资源能力建设和人才培养工程纳入企业发展战略。形成尊重劳动、尊重知识、尊重人才、尊重创造的人才氛围。完善吸纳人才、留住人才、激励人才、培养人才的新型用人机制。建立有利于人才队伍建设的科学合理的绩效考评体系和薪酬分配制度。加强经营管理人才、专业技术人才和技能人才三支队伍建设，尤其是开拓型经营管理人才、创新型专业技术人才和高素质技能人才的培养，为企业的快速发展提供强大的人才支持和智力保障。

Efforts should be made to establish a systematic, sustained, and long-term human resource management system that takes into account the short term. Firmly establish the view that talent is the primary resource and strengthening the construction of talent teams is the determining factor in enhancing the competitiveness of enterprises. Incorporate human resource capacity building and talent training projects into the development strategy of enterprises. Create a talent atmosphere that respects labor, knowledge, talent, and creativity. Improve the new employment mechanism for attracting, retaining, motivating, and cultivating talents. Establish a scientific and reasonable performance evaluation system and salary distribution system that is conducive to talent team construction. Strengthen the construction of three teams of business management talents, professional technical talents, and skilled talents, especially the cultivation of pioneering business management talents, innovative professional technical talents, and high-quality skilled talents, to provide strong talent support and intellectual guarantee for the rapid development of enterprises

(六) 管理战略 Management strategy

加强现代企业制度建设

强化战略管理，建立企业的战略管理体系和防范战略风险的机制，加强现代企业制度建设，完善以公司制为主要形式的现代企业制度。提高企业的执行力，明确界定各部门、岗位的目标、职责和权限，建立相应的授权、检查和逐级问责制度，确保其在授权范围内履行职能；设立涵盖企业所有运营环节的控制架构，并制订各层级之间的控制程序，保证董事会及高管层下达的指令能够严格执行。

Strengthen strategic management, establish a strategic management system and a mechanism to prevent Strategic risk, strengthen the construction of modern enterprise system, and improve the modern enterprise system in the form of company system. Improve the execution capability of the enterprise, clearly define the goals, responsibilities, and authorities of each department and position, establish corresponding authorization, inspection, and step-by-step accountability systems, and ensure that they perform their functions within the authorized scope; Establish a control structure that covers all operational aspects of the enterprise, and develop control procedures between different levels to ensure strict execution of instructions issued by the board of directors and senior management.

企业文化输出

塑造特色企业文化，注重以和谐为丰富内涵的优秀企业文化的挖掘、提炼和培育，建设适应企业发展战略和经营理念的清晰完整的企业文化体系，使企业文化的核心价值观得到广大员工的认同和遵循，形成企业的凝聚力和持续发展的内在动力。

Shaping distinctive corporate culture, emphasizing the excavation, refinement, and cultivation of excellent corporate culture with harmony as its rich connotation, and building a clear and complete corporate culture system that adapts to the development strategy and business philosophy of the enterprise, so that the core values of corporate culture are recognized and followed by the majority of employees, forming the cohesion and internal driving force for sustainable development of the enterprise



4

PART 4

联系方式 Contact Us

公司地址、电话、网站

Company address, phone number, website

Jiangsu Youcheng Zhixin Electromechanical Equipment Co., Ltd





(中国网站 Chinese websites)



(国际网站 International website)



(销售总监 Sales director)



总部办公室地址：江苏省昆山市巴城镇红杨路725号浩义泰产业园

Address of headquarters office: Haoyitai Industrial Park, No. 725, Hongyang Road, Bacheng Town, Kunshan, Jiangsu Province

客户专线【Hotline】：0512-88820290

联系人/Attn.：李娜 / Na Li 13382516956

国内网址【Domestic website】：<http://www.ycchuqiguan.com>

国际官网【International websites】：<https://www.youchengzhixin.com/>