

PROFESSIONAL FOOD MACHINE

COOKING EQUIPMENT

Digital Control Range

FOOD MACHINE

Good Helper In The Kitchen

2021



GUANGZHOU R&M MACHINERY CO., LTD

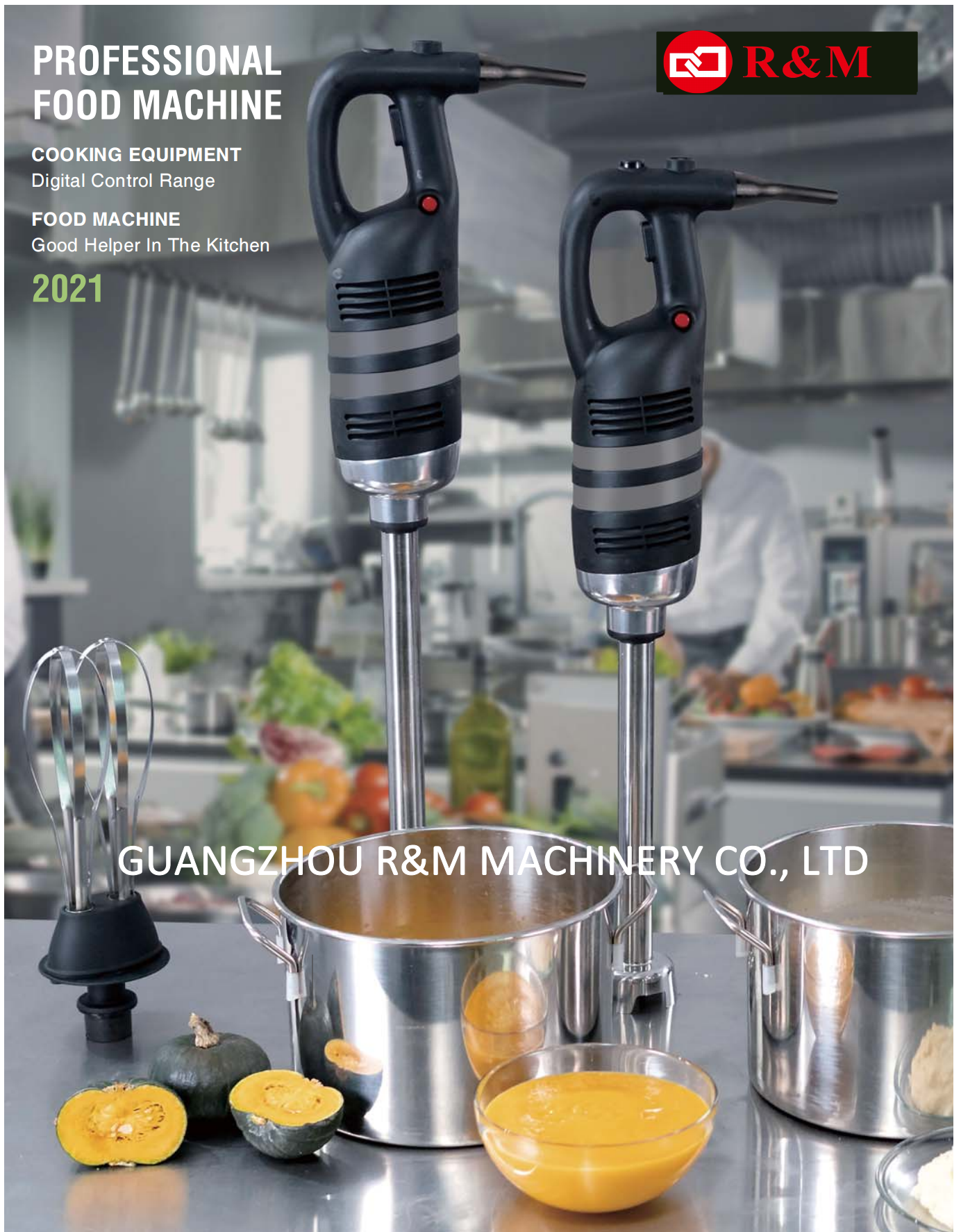

ABOUT US >>>



Show Room



Office



Warehouse





Guangzhou R&M Machinery CO., LTD.
R&M is a High-Tech enterprise specializing in food machinery manufacturing for Decades of experience. As an innovative brand, **R&M** focuses on the design, development, production and sales of unique style **food** machine. We attention to detail and precision, which enabled us with the aim of fully satisfying our clients by high-quality products and service. We serves globally customers in an efficient and innovative manner. When choosing a solution from **R&M**, you will be provided with tailored bakery solutions with unique know-how.

PRODUCTS

COOKING EQUIPMENT

FOOD MACHINE

CONTENTS

04	BAIN MARIE
05	SOUS VIDE COOKER
06	ELECTRIC DEEP FRYER
07	ELECTRIC HOT PLATE
08	ELECTRIC GRIDDLE
09-12	BOWL CUTTER
13-14	IMMERSION BLENDER (HAND MIXER)
15	ICE CRUSHER
15	ICE SHAVER
16	HEAVY DUTY COMBINATION PROCESSOR
17-20	COMPACT VEGETABLE CUTTER AND BLADES
21-24	VEGETABLE CUTTER AND BLADES
25	STRAIGHT KEBAB SLICER
26	KEBAB SLICER
27	MEAT MIXER
28	AUTOMATIC MEAT SLICER
29-30	SEMI-AUTOMATIC MEAT SLICER
31-32	MEAT GRINDER
33	CHEESE GRATER
33	MEAT GRINDER GRATER
34	ELECTRIC MEAT TENDERIZER/STRIPPER
35-36	POTATO PEELER
37	SAUSAGE STUFFER/FILLER

BAIN MARIES SERIES

BM150T/BM200T



BM150T



Drain Tap



Digital Control Panel



BM200T

TECHNIC PARAMETERS:

MODEL:	BM150T	BM200T
DESCRIPTION:	Bain Marie with drain valve	Bain Marie with drain valve
POWER:	800W	1200W
VOLTAGE:	220V-240V~ 50/60Hz	220V-240V~ 50/60Hz
FIT FOOD PAN SIZE:	GN 1/1 Gastronorm pan (not included)	GN 1/1 Gastronorm pan (not included)
WATER BATH DEPTH:	165mm	215mm
TEMPERATURE:	35-100°C	35-100°C
TIMER:	0 - 60 hrs (division 1 min)	0 - 60 hrs (division 1 min)
N.W./G.W.:	14.0/15.5kg	15.0/16.5kg
PACKAGE SIZE:	73x44x34cm	73x44x39cm

GENERAL FEATURE:

- Stainless steel construction
- Sophisticated digital controller
- Fits GN 1/1 size
- Safety thermal protection
- 35 - 100°C temperature control
- 0 - 6 hours timer, division 1 min
- Main rocker switch to shut off standby current
- Height adjustable alloy feet

SOUS VIDE COOKERS SERIES

SOU13L/SOU20L



SOU20L



SOU13L



Exhaust Valve



Sous Vide Rack

TECHNIC PARAMETERS:

	SOU13L	SOU20L
MODEL:	SOU13L	SOU20L
DESCRIPTION:	Sous Vide System	Sous Vide System
POWER:	800W	1200W
VOLTAGE:	220V-240V~ 50/60Hz 115V~ 60Hz	220V-240V~ 50/60Hz 115V~ 60Hz
WATER BATH:	355x325x200mm	530x325x200mm
CAPACITY:	13L	20L
NO. OF COOKING SPACE:	4	6
TEMPERATURE:	40 - 95°C	40 - 95°C
TIMER:	0 - 99 hrs (division 1 min)	0 - 99 hrs (division 1 min)
N.W./G.W.:	10.4/11.4 kg	13.0/14.0kg
PACKAGE SIZE:	53.5x43.5x35.5cm	71x43.5x35.5cm

GENERAL FEATURE:

- Stainless steel construction
- Sophisticated digital controller
- Stainless steel sous vide rack
- Safety thermal protection
- 40 - 95°C temperature control (precision to 0.1°C)
- 0 - 99 hrs minutes timer (division 1 minute)
- Main rocker switch to shut off standby current
- Height adjustable alloy feet
- Drain tap to release water
- Air tight lid

ELECTRIC DEEP FRYERS SERIES

DF350-9L/DF350-9L2

DF350-9L2



DF350-9L



Heating Element

GENERAL FEATURE:

- Stainless steel construction
- Sophisticated digital controller
- PID temperature control algorithm
- Heating element can be turned upward for easy cleaning of oil tank
- V-shape oil tank with effective cold zone
- Safety thermal protection
- 50 - 190°C temperature range
- 0 - 20 hrs timer (division 1 min)
- Drain tap for releasing oil
- Main rocker switch to shut off standby current
- Height adjustable alloy feet

TECHNIC PARAMETERS:

MODEL:	DF350-9L
DESCRIPTION:	Deep fryer, single tank
POWER:	3500W
VOLTAGE:	220V-240V~ 50/60Hz
	115V~ 60Hz
CAPACITY:	9L
TEMPERATURE:	50-190°C
TIMER:	0 - 20 hrs (division 1 min)
N.W./G.W.:	11.1/12.1kg
PACKAGE SIZE:	63x39.5x41.5cm

MODEL:	DF350-9L2
DESCRIPTION:	Deep fryer, twin tank
POWER:	2 x 3500W
VOLTAGE:	220V-240V~ 50/60Hz
	115V~ 60Hz
CAPACITY:	2 x 9 L
TEMPERATURE:	50-190°C
TIMER:	0 - 20 hrs (division 1 min)
N.W./G.W.:	20.2/21.7kg
PACKAGE SIZE:	68x63.5x41.5cm

V-shape Oil Tank & Cold Zone

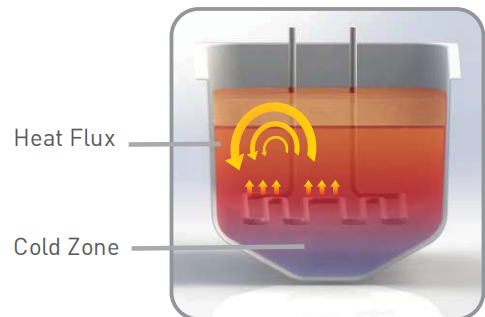

ELECTRIC HOT PLATES SERIES

HP300CR/HP300LG



HP300CR



HP300LG

GENERAL FEATURE:

- Stainless steel construction
- Digital controller
- Cast iron hotplate element 180mm dia.
- 1 - 13 power level
- Safety thermal protection
- 0 - 3 hours timer, division 1 min
- Main rocker switch to shut off standby current
- Height adjustable alloy feet

TECHNIC PARAMETERS:

MODEL:	HP300CR	HP300LG
DESCRIPTION:	Electric Hot Plates - crosswise	Electric Hot Plates - lengthwise
POWER:	1500W + 1500W	1500W + 1500W
VOLTAGE:	220V-240V~ 50/60Hz 115V~ 60Hz	220V-240V~ 50/60Hz 115V~ 60Hz
HOT PLATE DIAMETER:	180mm	180mm
HEATING ELEMENT:	OFF + 1 to 13 Levels	OFF + 1 to 13 Levels
TIMER:	0 - 3 hrs (division 1 min)	0 - 3 hrs (division 1 min)
N.W./G.W.:	11.4/12.4kg	10.9/11.9kg
PACKAGE SIZE:	68x40.5x25cm	68x40.5x25cm



Hot Plate Heating Element



Main Rocker Switch

ELECTRIC GRIDDLES SERIES

GD280CR/GD280LG

GENERAL FEATURE:

- Stainless steel construction
- Sophisticated digital controller
- Hard chrome plated grill plate
- Stainless steel crumb tray
- Safety thermal protection
- 50 - 300°C temperature control
- 0 - 60 minutes timer
- Main rocker switch to shut off standby current
- Height adjustable alloy feet



Dual Mode Timer

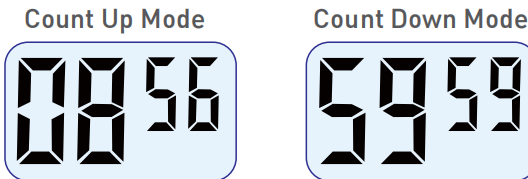

GD280LG



GD280CR

TECHNIC PARAMETERS:

MODEL:	GD280CR	GD280LG
DESCRIPTION:	Griddle - crosswise	Griddle - lengthwise
POWER:	2400W	2400W
VOLTAGE:	220V-240V~ 50/60Hz	220V-240V~ 50/60Hz
	115V~ 60Hz	115V~ 60Hz
COOKING AREA:	598 x 220mm	298 x 520mm
GRILL PLATE SURFACE:	Hard chrome plating	Hard chrome plating
GRILL PLATE:	Steel 10mm thick	Steel 10mm thick
TEMPERATURE:	50 - 300°C	50 - 300°C
TIMER:	0 - 60min (division 1 sec)	0 - 60min (division 1 sec)
N.W./G.W.:	23.3/24.3kg	23.6/24.6kg
PACKAGE SIZE:	72x41.5x28cm	73x41.5x28cm



Crumb Tray

BOWL CUTTER SERIES

LFC-5V1/LFC-8V1/LFC-12V1/LFC-18V1

LFC-5V2/LFC-8V2/LFC-12V2/LFC-18V2



Micro Switch



Control Panel



LFC-5V1/LFC-8V1/LFC-12V1/LFC-18V1

GENERAL FEATURE:

- Full stainless steel construction
- Strong cutlery steel knife
- Powerful and ventilated motor
- Safety microswitch included
- Transparent lid with opening to add ingredients during operation
- Scraper accessory ensures a perfect result
- The machine is designed and produced according to international standards for safety and hygiene.



TECHNIC PARAMETERS:

MODEL:	LFC-5V1	LFC-8V1	LFC-12V1	LFC-18V1
POWER:	800W	800W	1500W	1500W
VOLTAGE:	220V-240V~ 50/60Hz 115V~ 60Hz	220V-240V~ 50/60Hz 115V~ 60Hz	220V-240V~ 50/60Hz 115V~ 60Hz	220V-240V~ 50/60Hz 115V~ 60Hz
SPEED:	1500rpm(50Hz) 1725rpm(60Hz)	1500rpm(50Hz) 1725rpm(60Hz)	1500rpm(50Hz) 1725rpm(60Hz)	1500rpm(50Hz) 1725rpm(60Hz)
CAPACITY:	5L	8L	12L	18L
N.W./G.W.:	21.8/23.3kg	22.1/23.6kg	28.2/29.7kg	29.3/30.8kg
PACKAGE SIZE:	43.5X43.5X67cm	43.5X43.5X67cm	49.5X45.5X79.5cm	49.5X45.5X79.5cm



LFC-5V2/LFC-8V2/LFC-12V2/LFC-18V2



GENERAL FEATURE:

- Full stainless steel construction
- Strong cutlery steel knife
- Powerful and ventilated motor
- Safety microswitch included
- Transparent lid with opening to add ingredients during operation
- Scraper accessory ensures a perfect result
- Two speeds control and pulse function
- The machine is designed produced according to international standards for safety and hygiene.



"S" Smooth Blade In
LFC-5V1 / LFC-8V1



Twin "S" Smooth Blades In
LFC-12V1 / LFC-18V1 / ALL V2 Version

MODEL:	LFC-5V2	LFC-8V2	LFC-12V2	LFC-18V2
POWER:	1500W	1500W	2200W	2200W
VOLTAGE:	220V-240V~ 50/60Hz	220V-240V~ 50/60Hz	220V-240V~ 50/60Hz	220V-240V~ 50/60Hz
SPEED:	115V~ 60Hz LO.:1500rpm / HI.:2800rpm	115V~ 60Hz LO.:1500rpm / HI.:2800rpm	115V~ 60Hz LO.:1500rpm / HI.:2200rpm	115V~ 60Hz LO.:1500rpm / HI.:2200rpm
CAPACITY:	5L	8L	12L	18L
N.W./G.W.:	22.9/24.4kg	23.2/24.7kg	28.1/29.6kg	29.2/30.7kg
PACKAGE SIZE:	43.5X43.5X67cm	43.5X43.5X67cm	49.5X45.5X79.5cm	49.5X45.5X79.5cm

BOWL CUTTER SERIES

FC-5V1/FC-8V1/FC-12V1/FC-18V1

GENERAL FEATURE:

- Full stainless steel construction
- Strong cutlery steel knife
- Powerful and ventilated motor
- Safety microswitch included
- Transparent lid with opening to add ingredients during operation
- Scraper accessory ensures a perfect result
- The machine is designed and produced according to international standards for safety and hygiene.



TECHNIC PARAMETERS:

MODEL:	FC-5V1	FC-8V1	FC-12V1	FC-18V1
POWER:	800W	800W	1500W	1500W
VOLTAGE:	220V-240V~ 50/60Hz 115V~ 60Hz	220V-240V~ 50/60Hz 115V~ 60Hz	220V-240V~ 50/60Hz 115V~ 60Hz	220V-240V~ 50/60Hz 115V~ 60Hz
SPEED:	1500rpm(50Hz) 1725rpm(60Hz)	1500rpm(50Hz) 1725rpm(60Hz)	1500rpm(50Hz) 1725rpm(60Hz)	1500rpm(50Hz) 1725rpm(60Hz)
CAPACITY:	5L	8L	12L	18L
N.W./G.W.:	21.5/23.0kg	21.8/23.3kg	27.9/29.4kg	29/30.5kg
PACKAGE SIZE:	43.5X43.5X67cm	43.5X43.5X67cm	49.5X45.5X79.5cm	49.5X45.5X79.5cm

BOWL CUTTER SERIES

EFC-5V1/EFC-8V1/EFC-12V1/EFC-18V1



TECHNIC PARAMETERS:

MODEL:	EFC-5V1	EFC-8V1	EFC-12V1	EFC-18V1
POWER:	800W	800W	1500W	1500W
VOLTAGE:	220V-240V~ 50/60Hz 115V~ 60Hz	220V-240V~ 50/60Hz 115V~ 60Hz	220V-240V~ 50/60Hz 115V~ 60Hz	220V-240V~ 50/60Hz 115V~ 60Hz
SPEED:	1500rpm(50Hz) 1725rpm(60Hz)	1500rpm(50Hz) 1725rpm(60Hz)	1500rpm(50Hz) 1725rpm(60Hz)	1500rpm(50Hz) 1725rpm(60Hz)
CAPACITY:	5L	8L	12L	18L
N.W./G.W.:	21.5/23.0kg	21.8/23.3kg	27.9/29.4kg	29/30.5kg
PACKAGE SIZE:	43.5X43.5X67cm	43.5X43.5X67cm	49.5X45.5X79.5cm	49.5X45.5X79.5cm

IMMERSION BLENDER (HAND MIXER) SERIES

GENERAL FEATURE:

- Professional equipment particularly suited for ice cream shops, confectionery, restaurants and hotels etc.
- Elegant body design made from plastic, heavy duty hand mixer available in 4 motor sizes to meet the demands of any kitchens
- 280W, 450W, 650W and 850W ventilated motors, thermal overload protection and variable speed control switch
- Ergonomic handle for comfortable use
- Full stainless steel, high performance blade, all food contact parts in stainless steel



IB280AF/IB280AV

IB450AF/IB450AV

TECHNIC PARAMETERS:

POWER:	280W	450W
VOLTAGE:	220V-240V~ 50/60Hz / 115V~ 60Hz	220V-240V~ 50/60Hz / 115V~ 60Hz
SPEED:	20000rpm / 6000-20000rpm	16000rpm / 4000-16000rpm
INNER BOX SIZE:	46.5x17.5x9.5cm	55.5x29x11cm
MASTER BOX SIZE:	49.5x48.5x37cm (10PCS)	57x57x31cm (5PCS)



WALL HANGER FOR IMMERSION BLENDER

WB-1



WB-3



BLD160-U
Use for
IB280AF/IB280AV only



WIK185-U (0.81KGS)
Use for IB280AV only



BLD250-U



BLD300-U



BLD350-U



Emulsifying Blade
optional





IB650AF/IB650AV

IB850AF/IB850AV

650W

220V-240V~ 50/60Hz / 115V~ 60Hz

18000rpm / 8000-18000rpm

50x28x13.5cm

69X52X30cm (5PCS)

850W

220V-240V~ 50/60Hz / 115V~ 60Hz

18000rpm / 8000-18000rpm

60x28x13.5cm

69X62.5X30cm (5PCS)

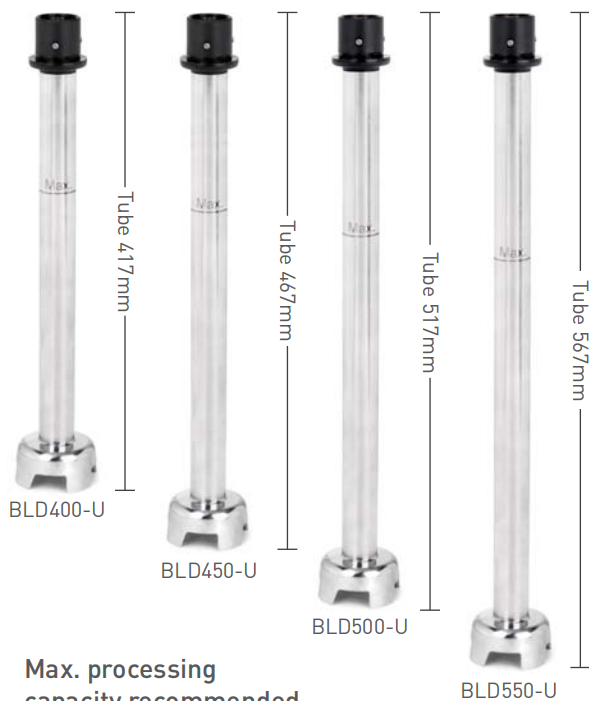

WIK250-U (0.9KGS)

Use for
IB450AV / IB650AV and IB850AV

SUPPORT BRACKET FOR
IMMERSION BLENDER

BTH



**Max. processing
capacity recommended**

MODELS	WEIGHT	BLD160-U	BLD250-U	BLD300-U	BLD350-U	BLD400-U	BLD450-U	BLD500-U	BLD550-U
WEIGHT		0.5 kg	0.9 kg	1.0 kg	1.13 kg	1.35 kg	1.5 kg	1.65 kg	1.8 kg
IB280	1.78 kg	10L	/	/	/	/	/	/	/
IB450	2.55 kg	/	20L	30L	50L	80L	100L	120L	/
IB650	3.60 kg	/	/	40L	60L	100L	140L	180L	220L
IB850	3.60 kg	/	/	50L	70L	120L	160L	200L	240L

ICE CRUSHER

IC80A

GENERAL FEATURE:

- Base made in aluminum alloy
- Stainless steel container
- Strong cutlery steel blade
- Safety microswitch included
- High capacity for professional use
- Ventilated motor with gear transmission for prolonged use
- The machine is designed and produced according to international standards for safety and hygiene.



Stainless Steel Blade



TECHNIC PARAMETERS:

MODEL:	IC80A
POWER:	200W
VOLTAGE:	220V-240V~ 50/60Hz 115V~ 60Hz
CAPACITY:	3L
N.W./G.W.:	5.4/7.1kg
PACKAGE SIZE:	38.5X25.5X58cm

ICE SHAVER

ISC-1 / ISC-2



ISC-1

TECHNIC PARAMETERS:

MODEL:	ISC-1	ISC-2
POWER:	300W	300W
SPEED:	1500rpm	1500rpm
VOLTAGE:	220V-240V~ 50/60Hz 115V~ 60Hz	220V-240V~ 50/60Hz 115V~ 60Hz
N.W./G.W.:	9.8/10.9kg	16.5/17.4kg
PACKAGE SIZE:	47X30.5X45.5cm	48X36.5X63.5cm



ISC-2

GENERAL FEATURE:

- Waterproof On/Off switch
- Durable stainless steel blade
- High efficiency & fast speed
- Ventilation motor and long lifespan
- Simple operation & easy to clean

HEAVY DUTY COMBINATION PROCESSOR SERIES

VC70MF



VC70MF



CB5 (5L)

CB8 (8L)

TECHNIC PARAMETERS:

MODEL:	VC70MF
POWER:	1500W
VOLTAGE:	220V-240V~ 50/60Hz
SPEED:	500-3000rpm
VOLTAGE:	115V~ 60Hz
SPEED:	300-1700rpm
N.W./G.W.:	27.3/31.5kg
PACKAGE SIZE:	54X41X73.5cm

GENERAL FEATURE:

- Strong and robust casting aluminum housing
- Very powerful and ventilated motor
- Detachable blades and discs
- Adjustable speeds control and pulse function
- Safety microswitch included
- Transparent lid with opening to add ingredients during operation
- Scraper accessory ensures a perfect result
- The machine is designed and produced according to international standards for safety and hygiene



LCD Control Panel

COMPACT VEGETABLE CUTTER MACHINE SERIES

VC20MF/VC30MV/VC40MR

GENERAL FEATURE:

- Direct drive motor at the single speed of 1500 rpm
- Detachable discs
- Interlocked apparatus included for safety use
- Kidney shape and round shape inlet for your choice
- Compact design and medium duty can meet most of daily kitchen use



VC30MV



VC20MF

VC40MR

4 STANDARD DISCS INCLUDED IN EVERY UNIT



SC002



SC004



GC003



GC007



Easy Assembling And Disassembling

TECHNIC PARAMETERS:

MODEL:	VC20MF	VC30MV	VC40MR
POWER:	400W	400W	400W
VOLTAGE:	220V-240V~ 50/60Hz	220V-240V~ 50/60Hz	220V-240V~ 50/60Hz
SPEED:	115V~ 60Hz 1500rpm(50Hz) 1800rpm(60Hz)	115V~ 60Hz 1500rpm(50Hz) 1800rpm(60Hz)	115V~ 60Hz 1500rpm(50Hz) 1800rpm(60Hz)
N.W./G.W.:	14.2/17.4kg	14.2/17.4kg	14.5/17.7kg
PACKAGE SIZE:	47X38.5X63cm	47.5X39X65cm	47.5X39X65cm



Convenient Fastener

COMPACT BOWL CUTTER SERIES

FC3SP/FC5SP

GENERAL FEATURE:

- It's designed to process all types of food.
- Polycarbonate lid designed to allow the addition of liquid or ingredients during processing.
- Single speed 1500 rpm for bowl cutter
- Smooth blade included
- Safety microswitch included



TECHNIC PARAMETERS:

MODEL:	FC3SP	FC5SP
POWER:	735W	735W
VOLTAGE:	220V-240V~ 50/60Hz 115V~ 60Hz	220V-240V~ 50/60Hz 115V~ 60Hz
SPEED:	1500rpm(50Hz) 1800rpm(60Hz)	1500rpm(50Hz) 1800rpm(60Hz)
BOWL CAPACITY:	3L	5L
N.W./G.W.:	14.3/15.8 kg	14.8/16.1 kg
PACKAGE SIZE:	38X36X52cm	38X36X52cm



COMPACT COMBINATION PROCESSOR SERIES

VB60CH/VB60CR/ VB60CN



VB60CR

CB3S (3L)
CB5S (5L)

GENERAL FEATURE:

- A cutting bowl and a vegetable cutter attachment works on the same plastic motor base.
- Polycarbonate lid designed to allow the addition of liquid or ingredients during processing.
- Single speed 1500 rpm for two attachments
- Compact design and medium duty can meet most of daily kitchen use
- Interlocked apparatus included for safety use
- Direct drive motor
- Detachable blades and discs

Attention: the cutting bowl is optional

TECHNIC PARAMETERS:

MODEL:	VB60CN	VB60CH	VB60CR
POWER:	735W	735W	735W
VOLTAGE:	220V-240V~ 50/60Hz	220V-240V~ 50/60Hz	220V-240V~ 50/60Hz
	115V~ 60Hz	115V~ 60Hz	115V~ 60Hz
SPEED:	1500rpm(50Hz)	1500rpm(50Hz)	1500rpm(50Hz)
	1800rpm(60Hz)	1800rpm(60Hz)	1800rpm(60Hz)
BOWL CAPACITY:	3L/5L	3L/5L	3L/5L
N.W./G.W.:	17.2/20.5 kg	17.2/20.5 kg	17.5/20.8 kg
PACKAGE SIZE:	47X38.5X63cm	47.5X39X65cm	47.5X39X65cm

BLADES OF VEGETABLE CUTTER COMPACT SERIES



GC002 For Grater / Shredder (2mm)



GC003 For Grater / Shredder (3mm)



JC202 Julienne Disc 2x2mm



GC005 For Grater / Shredder (5mm)



GC007 For Grater / Shredder (7mm)



JC404 Julienne Disc 4x4mm



SC001 For Slicer (1mm)



SC003 For Slicer (3mm)



JC808 Julienne Disc 8x8mm



SC002 / SC004 For Slicer (2mm / 4mm)



SC007 For Slicer (7mm)



VDH Disc Holder

VEGETABLE CUTTER MACHINE SERIES

MULTI-PURPOSE ELECTRIC VEGETABLE CUTTERS



VC60MS

Semi-Hopper + S/S Bottom Base

TECHNIC PARAMETERS:

MODEL: VC60MS
POWER: 550W
VOLTAGE: 220V-240V~ 50/60Hz
115V~ 60Hz
N.W./G.W.: 24.2/27.2kg
PACKAGE SIZE: 65X31.5X53.5cm



Polished and Anodized Aluminum
Hopper and Body

Die-casting Aluminum Hopper and Body



Small inlet for long vegetable i.e carrot, cucumber up to Ø55mm



Larger inlet up to Ø165mm



Use different discs for your needs



Magnetic switch

VC65MS

Round Hopper + S/S Bottom Base

TECHNIC PARAMETERS:

MODEL: VC65MS
 POWER: 750W
 VOLTAGE: 220V-240V~ 50/60Hz
 115V~ 60Hz
 N.W./G.W.: 24.9/28.2kg
 PACKAGE SIZE: 65X32.5X53.5cm



Polished and Anodized Aluminum Hopper and Body

Die-casting Aluminum Hopper and Body



5 STANDARD DISCS INCLUDED IN EVERY UNIT



GENERAL FEATURE:

- Versatile and efficient: you can quickly process food to achieve different results with an excellent finish
- Utmost hygiene: the components are manufactured from materials suitable for food handling and can be easily removed for fast cleaning
- Ventilated motor: powerful and low-noise can perform all processes effortlessly
- Controls with low-voltage (24V) switch
- Machines conforming to CE hygiene and safety standards
- Discs and blades for all kinds of processing

BLADES OF VEGETABLE CUTTER SERIES

For slicer



SP002 3 Blades / 2mm

For slicer



SP004 2 Blades / 4mm

Optional blades for crimping slicing



For Grater / Shredder



G003 Holes: 3mm

For Grater / Shredder



G005 Holes: 4.5mm

For Grater / Shredder



G007 Holes: 7mm

For Grater / Shredder



G002 Holes: 2mm

For Grater / Shredder



G010 Holes: 10mm



For Fine Grater



V001



For Julienne



J303 3X3mm

For Julienne



J404 4X4mm

Disc Holder



VCH



For Slicer 1mm

SA001 3 Blades



For Slicer 2mm

SA002 3 Blades



For Slicer 4mm

SA004 2 Blades



For Slicer 14mm

SA014 Single Blade



For Slicer 2/4/10mm

SS002 / SS004 / SS010



For Slicer 6mm

SA006 2 Blades



For Slicer 8mm

SA008 Single Blade



For Slicer 10mm

SA010 Single Blade



COMBINED BLADES OF VEGETABLE CUTTER



For French Fries

FS808 8X8mm

Work with SA008



For French Fries

FS100

SA010

FS100 10X10mm

Work with SA010

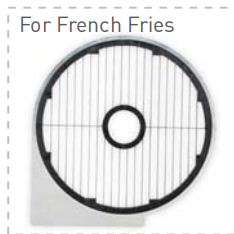

For French Fries

FR808 8X8mm

Only work in VC65MS with SA008

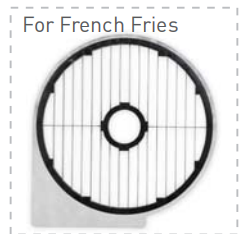

For French Fries

FR100 10X10mm

Only work in VC65MS with SA010



For Dicing

DS888 8X8X8mm

Work with SA008



For Dicing

DS1000 10X10X10mm

Work with SA010



For Dicing

DS140 14X14X14mm

Work with SA014

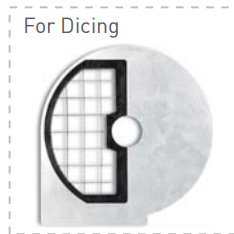

For Dicing

DS2000 20X20X14mm

Work with SA014

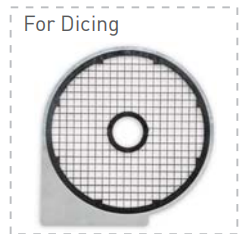

For Dicing

DR888 8X8X8mm

Only work in VC65MS with SA008



BLADE PACKAGE

Separated package for all kinds of vegetable cutting blades/discs.

DICE CLEANING KIT DCK08/DCK10



For Dicing

DR1000 10X10X10mm

Only work in VC65MS with SA010

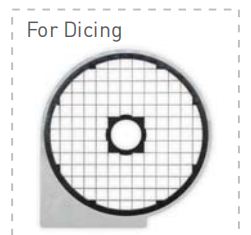

For Dicing

DR140 14X14X14mm

Only work in VC65MS with SA014

STRAIGHT KEBAB SLICER

KS80S

GENERAL FEATURE:

- Full stainless steel blade cover
- Adjustment ring and screw for desired thickness
- Metal anti-slip body, ergonomic design, safe and easy handling
- The front part is easily detachable for cleaning
- Wear-resistant switch
- One smooth blade included in the unit and one serrated blade included in the package
- An adapter and a slicer stand included



TECHNIC PARAMETERS:

MODEL:	KS80S
POWER:	80W
SPEED:	8000rpm
VOLTAGE:	220V-240V~ 50/60Hz 115V~ 60Hz
OUTPUT VOLTAGE:	24 VDC
FUSE:	3.15A
BLADE DIA.:	80mm
N.W./G.W.:	3.8/4.4kg
INNER BOX SIZE:	31.5x23x12.5cm
MASTER BOX SIZE:	48x34x39.5cm (6PCS)



6 colors for your choice

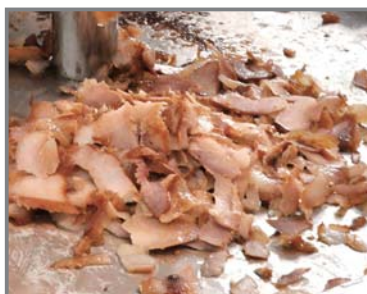
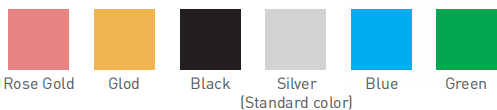

KEBAB SLICER SERIES



2 Smooth blades

KS100E

TECHNIC PARAMETERS

POWER: 80W
 VOLTAGE: 220V-240V~ 50/60Hz
 115V~ 60Hz
 CUTTING DEPTH: 0-8mm
 BLADE DIA.: 100mm
 CAPACITY: 60kg/h
 N.W/G.W.: 1.40/1.73kg
 INNER BOX SIZE: 23X18X26.5cm
 MASTER BOX SIZE: 56X47.5X28.3cm (6PCS)

GENERAL FEATURE:

- These are the perfect tools for obtaining tasty, well-prepared, and consistent slices of meat in a matter of seconds
- Adjustment ring and screw for desired thickness
- 304# Full stainless steel blade cover



2 Blades included
 (1 Smooth blade + 1 Serrated blade)

KS100T

TECHNIC PARAMETERS

POWER: 80W
 VOLTAGE: 220V-240V~ 50/60Hz
 115V~ 60Hz
 CUTTING DEPTH: 0-8mm
 BLADE DIA.: 100mm
 CAPACITY: 60kg/h
 N.W/G.W.: 1.25/1.55kg
 INNER BOX SIZE: 23X18X26.5cm
 MASTER BOX SIZE: 56X47.5X28.3cm (6PCS)



Thickness Adjusting Metal Ring



Smooth blade

Serrated blade



2 Blades included
 (1 Smooth blade + 1 Serrated blade)

KS100C

TECHNIC PARAMETERS

POWER: 80W
 CUTTING DEPTH: 0-8mm
 BLADE DIA.: 100mm
 CAPACITY: 60kg/h
 BATTERY: Li-ion 12V 2.0Ah*2PCS
 N.W/G.W.: 1.5/1.85kg
 INNER BOX SIZE: 20.5X19.5X16.5cm
 MASTER BOX SIZE: 60X42.5X18.5cm (6PCS)



Charger AU91SA

Battery LI1220B



FULL AISI 304 STAINLESS STEEL MEAT MIXER

MM55DW



GENERAL FEATURE:

- It is a commercial meat mixer, which is designed to effortlessly season ground meat thoroughly and consistently in a short time.
- It provides the best solution for butcher shops, supermarkets and meat processing industries.
- Modern design and strong AISI 304 stainless steel tank construction
- Removeable AISI 304 stainless steel mixing paddle
- Stainless steel cover with safety microswitch
- Forward and reverse switches
- Energy efficient motor with cooling fan and precision gear drive
- Circuit breaker and motor thermal protection included
- Minimum loading required: 30% max. capacity

TECHNIC PARAMETERS:

MODEL:	MM55DW
POWER:	550W
VOLTAGE:	220V-240V~ 50/60Hz 115V/60Hz
TANK DIMENSION:	27X32cm
TANK CAPACITY:	20kg
N.W./G.W.:	40/45kg
PACKAGE SIZE:	60x38x63cm

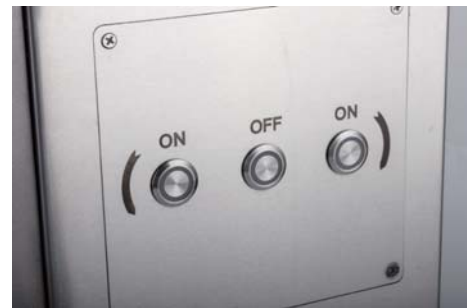

AUTOMATIC MEAT SLICER

MS300AS



TECHNIC PARAMETERS:

MODEL:	MS300AS
SLICING MOTOR POWER:	300W
RECIPROCATING MOTOR POWER:	400W
SLICING SPEED:	37 times/min
VOLTAGE:	220V-240V~ 50/60Hz 115V~ 60Hz
BLADE SIZE:	300mm
CUTTING THICKNESS:	0-11mm
N.W./G.W.:	46.3/56.5kg
PACKAGE SIZE:	60x57x58.5cm

GENERAL FEATURE:

- Stainless steel base
- Piston/rod system carriage motion
- Very Sturdy and easy to use and clean
- Fixed sharpener with double stones included
- Fan-cooled carriage motion motor with oil bath reduction
- Blade and carriage motion powered by two separate motors

SEMI-AUTOMATIC MEAT SLICER SERIES

MS-ST-U

- Construction in food grade aluminium, blade of hardened and chromium
- Meeting the most demanding sanitation requirements
- High precision slicing control thickness
- CE certification



Magnet Switch Built-in Sharpener

Cut off power when lifting the sharpener

Backside Knob Built-in magnet switch

Loosen the blade cover, Machine stops running



Long handle

Keep your hands off the moving blade



TECHNIC PARAMETERS

MODEL:	MS220ST-U	MS250ST-U	MS300ST-U
POWER:	0.15HP/120W	0.2HP/150W	1/3HP/250W
VOLTAGE:	220V-240V~ 50/60Hz	220V-240V~ 50/60Hz	220V-240V~ 50/60Hz
	115V~ 60Hz	115V~ 60Hz	115V~ 60Hz
BLADE SIZE:	220mm	250mm	300mm
THICKNESS:	0-9mm or 0-11mm	0-9mm or 0-11mm	0-11mm or 0-13mm
N.W./G.W.:	14.8/16.4kg	16.0/17.5kg	22.6/25.3kg
PACKAGE SIZE:	52X46X38cm	52X46X38cm	63X53X46cm

SEMI-AUTOMATIC MEAT SLICER SERIES

MS-ST

GENERAL FEATURE:

- Anodized aluminium alloy, increasing resistance to corrosion and wear
- Meeting the strictest sanitation requirements
- High precision slicing control thickness
- Food carriage mounted on ball bearings featuring exceptionally smooth running
- Attractive design suitable for any open kitchen or deli shop
- The smooth finish is durable and easy to clean



MS220ST



MS250ST



MS275ST



MS300ST



All Slicer Series Can Be Teflon Coated For Choice



Anodized Aluminum Surface, Nice Slicer Carriage, Pressing Plate



Thickness Adjusting Dial Knob
Water Proof On-Off Switch Button

TECHNIC PARAMETERS

MODEL:	MS220ST	MS250ST	MS275ST	MS300ST
POWER:	0.15HP/120W	0.2HP/150W	0.25HP/200W	1/3HP/250W
VOLTAGE:	220V-240V~ 50/60Hz	220V-240V~ 50/60Hz	220V-240V~ 50/60Hz	220V-240V~ 50/60Hz
	115V~ 60Hz	115V~ 60Hz	115V~ 60Hz	115V~ 60Hz
BLADE SIZE:	220mm	250mm	275mm	300mm
THICKNESS:	0-9mm	0-9mm	0-9mm	0-11mm
N.W./G.W.:	14.3/15.3kg	15.0/16.2kg	16.0/17.9kg	22.3/25.0kg
PACKAGE SIZE:	52X46X38cm	52X46X38cm	57X46X38.5cm	63X53X46cm

MEAT GRINDER SERIES

MG12HD / MG22HD

GENERAL FEATURE:

- Full Stainless steel housing with brush finish
- Housing, food grade chopper, strict with international hygiene standard
- Spiral meat grinder head, high efficiency and hard to be jammed
- Energy efficient motor with cooling fan and precision gear drive
- The circuit with overload and over current protection
- Conforms to North America standards Including ETL, NSF

Attachment: 6mm & 8mm perforated plates, 1 crossing knife and 1 sausage making tube



TECHNIC PARAMETERS

MODEL: MG12HD
 POWER: 3/4HP/550W
 VOLTAGE: 220V-240V~ 50/60Hz
 115V~ 60Hz
 N.W./G.W.: 22.8/25.2kg
 PACKAGE SIZE: 47X34X46cm

MODEL: MG22HD
 POWER: 1.2HP/900W
 VOLTAGE: 220V-240V~ 50/60Hz
 115V~ 60Hz
 N.W./G.W.: 30.0/33.3kg
 PACKAGE SIZE: 57X36X51.5cm



MEAT GRINDER ENTERPRISE SYSTEM



Meat Tenderizer Attachment
THN-12



Meat Cutter Attachment
FC-12



MG-MD MEAT GRINDER SERIES



TECHNIC PARAMETERS

MODEL:	MG12MD	MG22MD	MG32MD
POWER:	0.75HP/550W	1HP/735W	1.2HP/900W
VOLTAGE:	220V-240V~ 50/60Hz 115V~ 60Hz	220V-240V~ 50/60Hz 115V~ 60Hz	220V-240V~ 50/60Hz 115V~ 60Hz
N.W/G.W.:	21.5/24.5kg	24.2/27.0kg	29/31.7kg
PACKAGE SIZE:	50X31.5X55cm	50X31.5X55cm	49.5X32X58cm

GENERAL FEATURE:

- Housing constructed in aluminum alloy, food grade chopper, strict with international hygiene standard
- Spiral meat grinder head, high efficiency and hard to be jammed
- Energy efficient motor with cooling fan and precision gear drive, the circuit with overload and over current protection
- CE certification



MEAT GRINDER
ENTERPRISE SYSTEM





MEAT GRINDER SERIES

MG12ID/MG22ID/MG32ID

GENERAL FEATURE:

- Full stainless steel mirror polished housing, food grade chopper, strict with international hygiene standard
- Spiral meat grinder head, high efficiency and hard to be jammed
- Energy efficient motor with cooling fan and precision gear drive,
- The circuit with overload and over current protection

TECHNIC PARAMETERS

MODEL:	MG12ID	MG22ID	MG32ID
POWER:	1HP/735W	1.2HP/900W	1.5HP/1100W
CAPACITY:	120kg/h	220kg/h	300kg/h
N.W/G.W.:	27.5/29.5kg	31.0/34.0kg	36.8/39.2kg
PACKAGE SIZE:	62X35.7X54cm	62X37X54cm	67X37X54cm
VOLTAGE:	220V-240V~ 50/60Hz / 115V~ 60Hz		

Attachment: 6mm & 8mm perforated plates, 1 crossing knife and 1 sausage making tube

CHEESE GRATER

CG55SH

GENERAL FEATURE:

- Interlock handle - Prevents grater from operating unless the handle presses down
- Hand guard grid - For operator safety and injury prevention
- Direct gear driven motor - Longer wear with no belts or chains to replace

NOTE: FOR GRATING HARD CHEESE ONLY.

TECHNIC PARAMETERS

POWER:	0.75HP/550W
VOLTAGE:	220V-240V~ 50/60Hz
	115V~ 60Hz
N.W/G.W.:	16/18kg
PACKAGE SIZE:	49X32.5X48.5cm



MEAT GRINDER GRATER

CG22DM

GENERAL FEATURE:

- Interlock handle - Prevents grater from operating unless the handle presses down
- Hand guard grid - For operator safety and injury prevention
- Direct gear driven motor - Longer wear with no belts or chains to replace
- Stainless steel pan and grater drum - For sanitary operation and easy cleaning

NOTE: FOR GRATING HARD CHEESE ONLY.

TECHNIC PARAMETERS

POWER:	1.2HP/900W
VOLTAGE:	220V-240V~ 50/60Hz
	115V~ 60Hz
CAPACITY:	Meat Mincer : 180kg/h
	Cheese Grater: 60kg/h
N.W/G.W.:	27/30kg
PACKAGE SIZE:	68X33.5X58cm



ELECTRIC MEAT TENDERIZER/ STRIPPER TR8SH

GENERAL FEATURE:

- Robust and full stainless steel model, no sharp corner
- Meets the hygiene and all safety regulations
- Simple and easy operation and cleaning
- Tenderizer, meat stripper attachments for your choice

TECHNIC PARAMETERS

POWER: 350W
 VOLTAGE: 220V-240V~ 50/60Hz
 115V~ 60Hz
 N.W./G.W.: 14.3/15.7kg
 PACKAGE SIZE: 56X30.5X56cm



MSA Meat Stripper Attachment

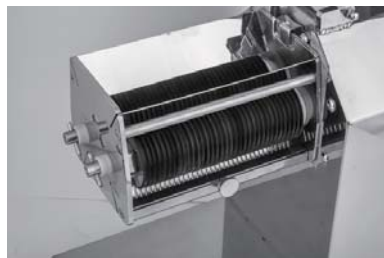

N.W./G.W.: 4.1/4.3kg
 PACKAGE SIZE: 28X17X18cm

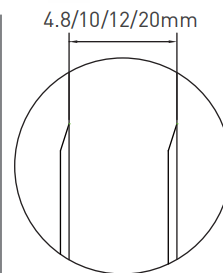
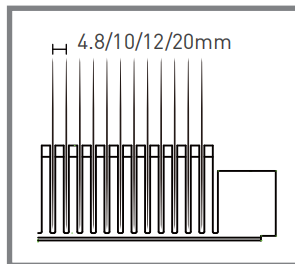

TDA Tenderizer Attachment A



N.W./G.W.: 3.8/4.0kg
 PACKAGE SIZE: 28X17X18cm

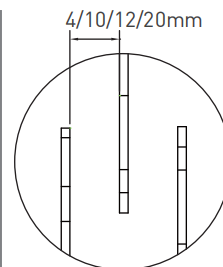
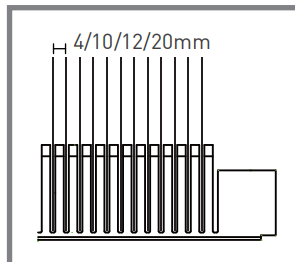

TDB Tenderizer Attachment B



N.W./G.W.: 2.9/3.1kg
 PACKAGE SIZE: 28X17X18cm



OPTIONAL
ACCESSORY

POTATO PEELER COUNTERTOP

PP5ST Countertop / PP10SF Countertop

GENERAL FEATURE:

- High efficiency, each load stuffing takes only 2-3 minutes
- International hygiene and safety standards, easy to operate and clean
- Adjustable S/S feet can be fixed to the floor
- Microswitches built-in the lid and the outlet opening
- Precise mechanical timer.



PP5ST Countertop



PP10SF Countertop



TECHNIC PARAMETERS

MODEL: PP5ST Countertop

POWER: 550W

VOLTAGE: 220V-240V~ 50/60Hz
115V~ 60Hz

CAPACITY: 70-100kg/h

VOLUME: 5KG/12L

N.W./G.W.: 33.2/43.3kg

PACKAGE SIZE: 71X62X81cm

MODEL: PP10SF Countertop

POWER: 750W

VOLTAGE: 220V-240V~ 50/60Hz
115V~ 60Hz

CAPACITY: 130-200kg/h

VOLUME: 10KG/22L

N.W./G.W.: 33.7/44.2kg

PACKAGE SIZE: 71X62X86cm

POTATO PEELER

PP5ST / PP10SF / PP18SF

GENERAL FEATURE:

- High efficiency, each load stuffing takes only 2-3 minutes
- International hygiene and safety standards, easy to operate and clean
- Adjustable S/S feet can be fixed to the floor
- Microswitches built-in the lid and the outlet opening
- Precise mechanical timer.



PP5ST



PP10SF



PP18SF



Potato Peeling Disc



Filter



Micro Switch



Switches and Timer

TECHNIC PARAMETERS

MODEL: PP5ST
POWER: 550W
VOLTAGE: 220V-240V~ 50/60Hz
115V~ 60Hz
CAPACITY: 70-100kg/h
VOLUME: 5KG/12L
N.W./G.W.: 38.6/49.5kg
PACKAGE SIZE: 71X62X99cm

MODEL: PP10SF
POWER: 750W
VOLTAGE: 220V-240V~ 50/60Hz
115V~ 60Hz
CAPACITY: 130-200kg/h
VOLUME: 10KG/22L
N.W./G.W.: 39.0/50.5kg
PACKAGE SIZE: 71X62X104cm

MODEL: PP18SF
POWER: 1100W
VOLTAGE: 220V-240V~ 50/60Hz
115V~ 60Hz
CAPACITY: 240-360kg/h
VOLUME: 18KG/28L
N.W./G.W.: 41.8/54.5kg
PACKAGE SIZE: 71X62X119cm

SAUSAGE STUFFER/FILLER

GENERAL FEATURE:

- Light-duty model, easy to be operated
- Include 4 plastic sausage making tubes: 10/20/30/35mm, S/S making tubes selectable
- The full stainless steel cylinder, the food approved aluminum piston with special finishing
- The solid rack, the precision gears and the accurate manufacturing of all mechanical details ensure a perfect working, the maximum efficiency and long life.



SS-3V

CAPACITY: 3L
N.W./G.W.: 8.6/9.6kg
SIZE: 61X35X31cm



SS-3H



CAPACITY: 3L
N.W./G.W.: 7.4/8.4kg
SIZE: 60X26X24cm

SS-5H



CAPACITY: 5L
N.W./G.W.: 8.7/9.8kg
SIZE: 64X26X24cm

SS-7H



CAPACITY: 7L
N.W./G.W.: 9.5/10.7kg
SIZE: 64X28X26cm



SS-5V

CAPACITY: 5L
N.W./G.W.: 9.3/11.1kg
SIZE: 73X35X31cm



SS-7V

CAPACITY: 7L
N.W./G.W.: 10.4/12.1kg
SIZE: 74X38X35cm

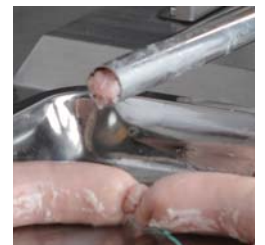



“The product comes from the life, comes from the social need”

Our idea is to provide for the society more advanced, more convenient, more simpler and effective tool & equipment, make own one diligently For the happy life, We have paid attention and have maintained diligently with the tool user's exchange and service

“Learn more from customers and thanks !”

We welcome the customer and people's any comment and suggestion wholeheartedly, our each product's innovation and company's development possibly benefits from your valued suggestion, here, we also thank the warm-hearted friend, thanks customer's consistent support.

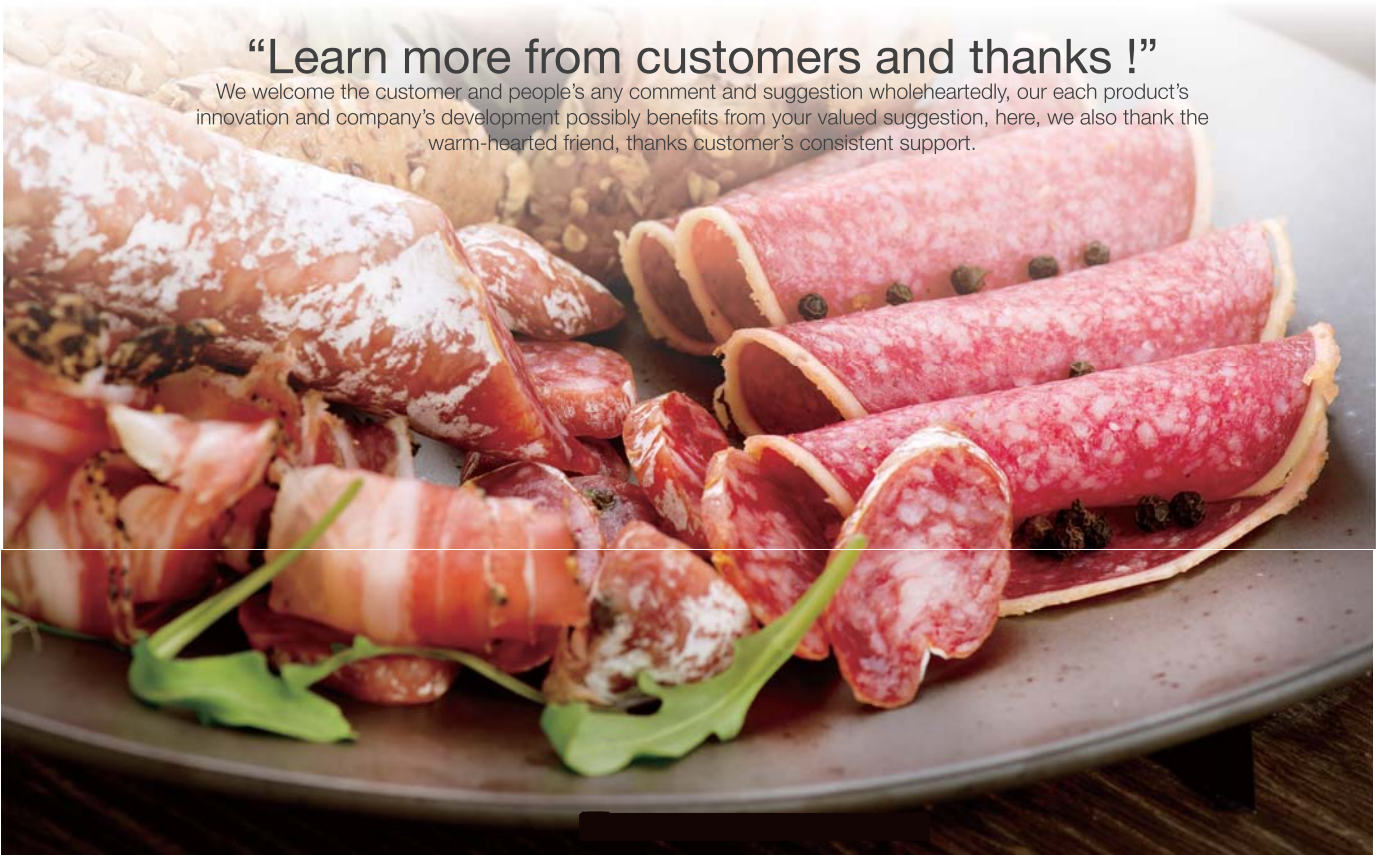

GUANGZHOU R&M MACHINERY CO., LTD

广州市荣麦烘焙食品机械制造有限公司.

地址：广州市南沙区榄核镇民生路117号

Address: No.117, Minsheng Road, Lanhe Town, Nansha District, Guangzhou, China.

电话Tel: +86-20-34917123

邮箱Email: rmachinery@126.com

中文官网: www.rmjxgs.com

Website: www.bakerovens.com

www.rmachinery.com