



厨房设备系列

KITCHEN EQUIPMENT SERIES

广州市荣麦烘焙食品机械制造有限公司
GUANGZHOU R&M MACHINERY CO., LTD.

地址：广州市南沙区榄核镇民生路117号
Address: No. 117, Minsheng Road, Lanhe Town, Nansha District, Guangzhou, China.

电话 Tel: 020-34917123
邮箱 Email: rmachinery@126.com
Website: www.rmachinery.com



万能蒸烤箱系列 Combi-steamer Series



ELECTRIC
3N~380V



标准版Manual
EOA-61-CMP
电子版可存储50个常用菜单



电脑版Digital
EOA-61-AC
电脑版可存储100个常用菜单

特性:

- 1.全不锈钢结构,内膛拉伸圆角设计、无死角、易清洗.
- 2.高效加热控制、极速升温.
- 3.电子版可存储50个常用菜单,可长期方便使用.
- 4.电脑版可存储100个常用菜单,功能更强大.
- 5.360度热风加热,蒸汽功能,温度无死角更均匀.
- 6.蒸汽锅炉喷雾功能保证足够的蒸汽量.
- 7.肉针测温功能,可保障食物内部的熟透程度.
- 8.冷热风交换,排汽功能,烘烤不串味.
- 9.全自动三级清洗功能,让你更省人力.

万能蒸烤箱系列 Combi-steamer Series

Table Top 6 Layer Combi-Oven

型号	Model	标准版 EOA-61-CMP	电脑版 EOA-61-AC
清洗功能	Cleaning	自动 Auto	自动 Auto
容量	Capacity	6*1/1 GN	
每天烹制份数	Output	30-80	
纵向插槽	Pan size	1/1,1/2,2/3,1/3,2/8GN	
长度	Width	847mm	
宽度	Depth	771mm	

高度	Height	782mm
进水口	Infall	R3/4"
出水口	Outfall	DN 50
水压	Water Pressure	150-600kPa或者0.15-0.6Mpa
重量	N/W	112.5kg
设备功率	Hp	11kW
保险丝	Fuse	3*16A
电源连接	Volts	3NAC 380V
热气功率	Roast Power	10kW
蒸汽功率	Steam Power	9kW

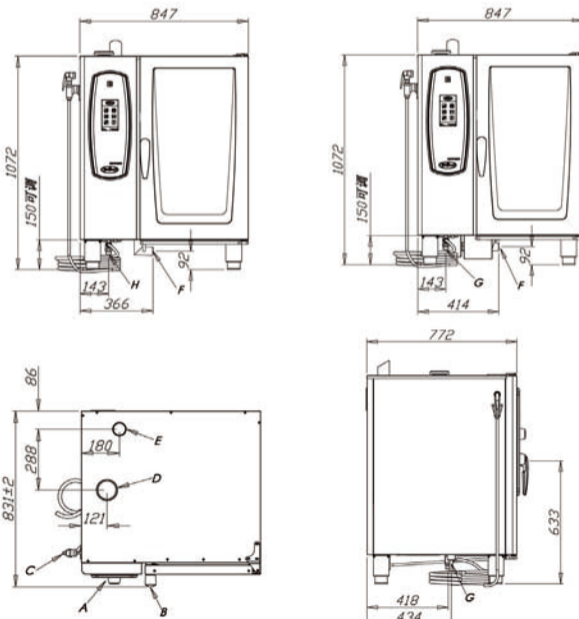

- A: 操作面板
- B: 门把手
- C: 手动水枪
- D: 冷空气进气口
- E: 排气管
- F: (DN50) 排水口
- G: G 3/4 进水口
- H: 5x6² 电缆线接口

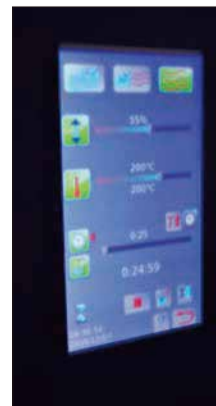

万能蒸烤箱系列 Combi-steamer Series



ELECTRIC
3N~380V



标准版 Manual
EOA-10-CMP
电子版可存储50个常用菜单



电脑版 Digital
EOA-10-AC
电脑版可存储100个常用菜单

特性:

- 1.全不锈钢结构，内膛拉伸圆角设计，无死角、易清洗。
- 2.高效加热控制，极速升温。
- 3.电子版可存储50个常用菜单，可长期方便使用。
- 4.电脑版可存储100个常用菜单，功能更强大。
- 5.360度热风加热，蒸汽功能，温度无死角更均匀。
- 6.蒸汽锅炉喷雾功能保证足够的蒸汽量。
- 7.肉针测温功能，可保障食物内部的熟透程度。
- 8.冷热风交换，排气功能，烘烤不串味。
- 9.全自动三级清洗功能，让你更省人力。

- 1.Efficient heating controller, heating fast
- 2.All stainless steel body, oven chamber stretched by round corner, easy to cleaning
- 3.With 50 commonly menus in manual type oven for long-term use
- 4.With 100 menus in digital controlled type, multifunction
- 5.With 360 degrees hot air heating, steam function, make temperature more uniform
- 6.The steam boiler spray function ensures sufficient steam.
- 7.Temperature sensor inside the food ensure the food to be cooked
- 8.Hot and cold air exchange, exhaust function, keep food fresh when baking and roasting
- 9.Automatic three-level cleaning function, save time and energy



万能蒸烤箱系列 Combi-steamer Series

Table Top 10 Layer Combi-Oven

型号	Model	标准版 EOA-10-CMP	电脑版 EOA-10-AC
清洗功能	Cleaning	自动 Auto	自动 Auto
容量	Capacity	10*1/1 GN	
每天烹制份数	Output	80-150	
纵向插槽	Pan size	1/1, 1/2, 2/3, 1/3, 2/8GN	
长度	Width	847mm	
宽度	Depth	771mm	

高度	Height	1060mm
进水口	Infall	R3/4"
出水口	Outfall	DN 50
水压	Water Pressure	150-600kPa或者0.15-0.6Mpa
重量	N/W	132.5kg
设备功率	Hp	18.6kW
保险丝	Fuse	3*32A
电源连接	Volts	3NAC 380V
热气功率	Roast Power	18kW
蒸汽功率	Steam Power	18kW

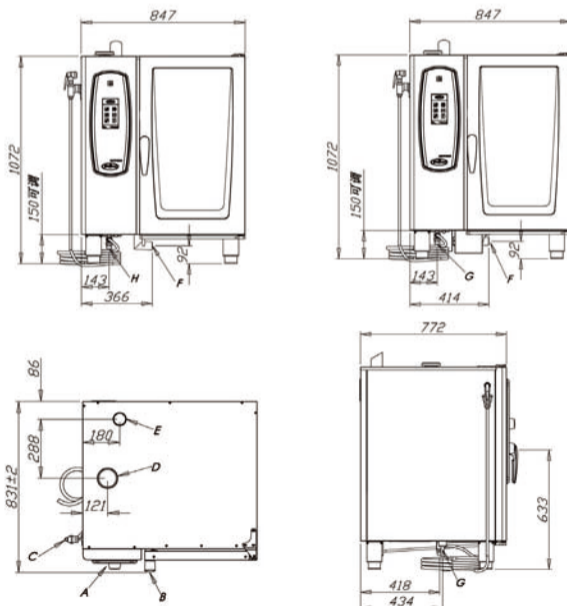

- A: 操作面板
- B: 门把手
- C: 手动水枪
- D: 冷空气进气口
- E: 排气管
- F: (DN50) 排水口
- G: G 3/4 进水口
- H: 5x6² 电缆接口



烘烤 探头控温

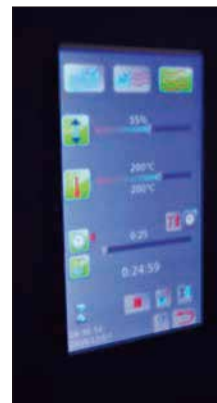

万能蒸烤箱系列 Combi-steamer Series

ELECTRIC
3N~380V



标准版 Manual
EOA-20-CMP
电子版可存储50个常用菜单



电脑版 Digital
EOA-20-AC
电脑版可存储100个常用菜单

特性:

- 1.全不锈钢结构,内膛拉伸圆角设计,无死角、易清洗.
- 2.高效加热控制、极速升温.
- 3.电子版可存储50个常用菜单,可长期方便使用.
- 4.电脑版可存储100个常用菜单,功能更强大.
- 5.360度热风加热,蒸汽功能,温度无死角更均匀.
- 6.蒸汽锅炉喷雾功能保证足够的蒸汽量.
- 7.肉针探温功能,可保障食物内部的熟透程度.
- 8.冷热风交换,排气功能,烘烤不串味.
- 9.全自动三级清洗功能,让你更省人力.

- 1.Efficient heating controller, heating fast
- 2.All stainless steel body, oven chamber stretched by round corner, easy to cleaning
- 3.With 50 commonly menus in manual type oven for long-term use
- 4.With 100 menus in digital controlled type, multifunction
- 5.With 360 degrees hot air heating, steam function, make temperature more uniform
- 6.The steam boiler spray function ensures sufficient steam.
- 7.Temperature sensor inside the food ensure the food to be cooked
- 8.Hot and cold air exchange, exhaust function, keep food fresh when baking and roasting
- 9.Automatic three-level cleaning function, save time and energy



万能蒸烤箱系列 Combi-steamer Series

20Layer Combi-Oven

型号	标准版 Manual EOA-20-CMP	电脑版 Digital EOA-20-AC
清洗功能	Cleaning 自动 Auto	自动 Auto
容量	Capacity	20*1/1 GN
每天烹制份数	Output	150-300
纵向插槽	Pan size	1/1,1/2,2/3,1/3,2/8GN
长度	Width	879mm
宽度	Depth	791mm

高度	Height	1880mm
进水口	Infall	R3/4"
出水口	Outfall	DN 50
水压	Water Pressure	150-600kPa或者0.15-0.6Mpa
重量	N/W	267kg
设备功率	Hp	37kW
保险丝	Fuse	3*63A
电源连接	Volts	3NAC 380V
热气功率	Roast Power	36kW
蒸汽功率	Steam Power	18kW

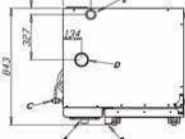
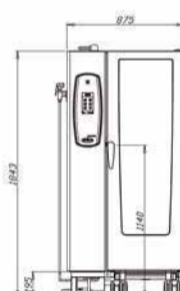
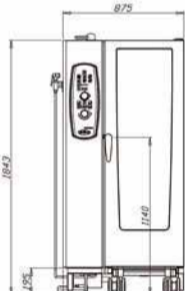

A: 操作面板
B: 门把手
C: 手动水枪
D: 冷空气进气口
E: 排气窗
F: (DN50) 排水口
G: G-3/4"进水口
H: Sx10°电熔线接口
I: 餐车

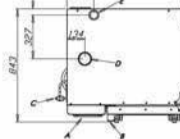

A: 操作面板
B: 门把手
C: 手动水枪
D: 冷空气进气口
E: 排气窗
F: (DN50) 排水口
G: G-3/4"进水口
H: Sx10°电熔线接口
I: 餐车



万能蒸烤箱系列 Combi-steamer Series



经济型系列



EOA-10-MP

万能蒸烤箱系列 Combi-steamer Series

Table Top 10 Layer Combi-Oven

型号	Model	EOA-10-MP
清洗功能	Cleaning	人工 Manual
容量	Capacity	10*1/1 GN
每天烹制份数	Output	80-150
纵向插槽	Pan size	1/1, 1/2, 2/3, 1/3, 2/8GN
长度	Width	817mm
宽度	Depth	771mm
高度	Height	1060mm

进水口	Infall	R3/4"
出水口	Outfall	DN 25
水压	Water Pressure	150-600kPa或者0.6-3Mpa
重量	N/W	
设备功率	Hp	9kW
保险丝	Fuse	3*16A
电源连接	Volts	3NAC 380V



特性:

1. 全不锈钢结构，内膛拉伸圆角设计、无死角、易清洗。
2. 高效加热控制、极速升温。
3. 电子版可存储50个常用菜单，可长期方便使用。
4. 360度热风加热，蒸汽功能，温度无死角更均匀。
5. 肉针测温功能，可保障食物内部的熟透程度。
6. 冷热风交换，排气功能，烘烤不串味。
7. 手动高压清洗功能，让你更省人力。

1. Efficient heating controller, heating fast
2. All stainless steel body, oven chamber stretched by round corner, easy to cleaning
3. With 50 commonly menus in manual type oven for long-term use
4. With 100 menus in digital controlled type, multifunction
5. With 360 degrees hot air heating, steam function, make temperature more uniform
6. The steam boiler spray function ensures sufficient steam.
7. Manual three-level cleaning function, save time and energy

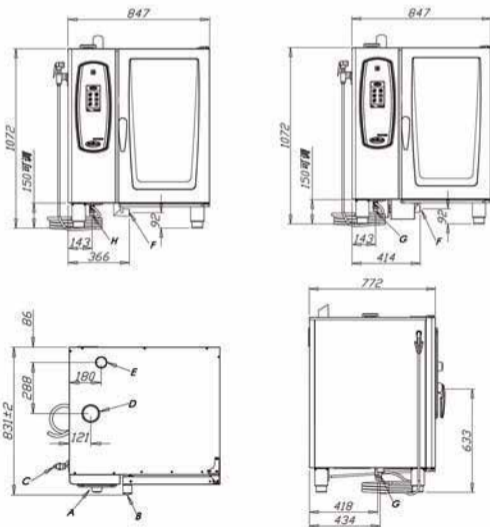

焖烤



探头控温

万能蒸烤箱系列 Combi-steamer Series



经济型系列

ELECTRIC
3N~380V



万能蒸烤箱系列 Combi-steamer Series

EOA-61-MP

Table Top 6 Layer Combi-Oven

型号	Model	EOA-61-MP
清洗功能	Cleaning	人工 Manual
容量	Capacity	6*1/1 GN
每天烹制份数	Output	30-80
纵向插槽	Pan size	1/1, 1/2, 2/3, 1/3, 2/8GN
长度	Width	817mm
宽度	Depth	771mm
高度	Height	782mm

进水口	Infall	R3/4"
出水口	Outfall	DN 25
水压	Water Pressure	150-600kPa或者0.6-3Mpa
重量	N/W	
设备功率	Hp	9kW
保险丝	Fuse	3*16A
电源连接	Volts	3NAC 380V



经济型系列

ELECTRIC
3N~380V



EOA-41-MP

万能蒸烤箱系列 Combi-steamer Series

Table Top 4 Layer Combi-Oven

型号	Model	EOA-41-MP
清洗功能	Cleaning	人工 Manual
容量	Capacity	4*1/1 GN
每天烹制份数	Output	30-80
纵向插槽	Pan size	1/1, 1/2, 2/3, 1/3, 2/8GN
长度	Width	817mm
宽度	Depth	771mm
高度	Height	504mm

进水口	Infall	R3/4"
出水口	Outfall	DN 25
水压	Water Pressure	150-600kPa或者0.6-3Mpa
重量	N/W	
设备功率	Hp	9kW
保险丝	Fuse	3*16A
电源连接	Volts	3NAC 380V



万能蒸烤箱系列 Combi-steamer Series



经济型系列

ELECTRIC
220V



万能蒸烤箱(小6层)
Combi-steamer Series

EOA-61-MX

Table Top 6 Layer Combi-Oven

型号	Model	EOA-61-MX
清洗功能	Cleaning	人工 Manual
容量	Capacity	6*2/3GN
每天烹制份数	Output	30-80
纵向插槽	Pan size	1/2,2/3,1/3,2/8GN
长度	Width	687mm
宽度	Depth	681mm
高度	Height	740mm

进水口	Infall	R3/4"
出水口	Outfall	DN 25
水压	Water Pressure	150-600kPa或者0.6-3Mpa
重量	N/W	85kg
设备功率	Hp	6kW
保险丝	Fuse	3*16A
电源连接	Volts	220V



经济型系列

ELECTRIC
220V



EOA-41-MX

万能蒸烤箱系列(小4层)
Combi-steamer Series

Table Top 4 Layer Combi-Oven

型号	Model	EOA-41-MX
清洗功能	Cleaning	人工 Manual
容量	Capacity	4*2/3 GN
每天烹制份数	Output	30-80
纵向插槽	Pan size	1/2,2/3,1/3,2/8GN
长度	Width	687mm
宽度	Depth	681mm
高度	Height	642mm

进水口	Infall	R3/4"
出水口	Outfall	DN 25
水压	Water Pressure	150-600kPa或者0.6-3Mpa
重量	N/W	85kg
设备功率	Hp	6kW
保险丝	Fuse	3*16A
电源连接	Volts	220V



热风电烤箱(带喷雾)系列

Convection Oven (With Spray) Series



热风电烤箱(带喷雾)

Convection Oven (With Spray)

ELECTRIC
3N~380V

特性:

1. 全不锈钢结构, 内腔拉伸圆角设计, 无死角、易清洗。
All stainless steel body, oven chamber stretched by round corner, easy to cleaning
2. 高效加热控制, 极速升温。
Efficient heating controller, heating fast
3. 电子版可存储10个常用菜单, 每个菜单可设置5个步骤, 可长期方便使用。
With 10 commonly menus in manual type oven for long-term use
4. 360度正反转热风加热, 温度无死角更均匀。
With 360 degrees hot air heating, make temperature more uniform
5. 手动或自动蒸汽喷雾功能保证足够的蒸汽量。
The steam boiler spray function ensures sufficient steam.



EOA-81F

热风电烤箱(带喷雾)8层

Convection Oven (With Spray)

型号	Model	EOA-81F
清洗功能	Cleaning	人工 Manual
容量	Capacity	600X400X25mmX8PCS
每天烹制份数	Output	30-80
纵向插槽	Pan size	600X400X25mm
长度	Width	817mm
宽度	Depth	771mm
高度	Height	1060mm

进水口	Infall	R3/4"
出水口	Outfall	DN 25
水压	Water Pressure	150-600kPa或者0.6-3Mpa
重量	N/W	
设备功率	Hp	9kW
保险丝	Fuse	3*16A
电源连接	Volts	3NAC 380V



热风电烤箱(带喷雾)

Convection Oven (With Spray)

ELECTRIC
3N~380V

特性:

1. 全不锈钢结构, 内腔拉伸圆角设计, 无死角、易清洗。
All stainless steel body, oven chamber stretched by round corner, easy to cleaning
2. 高效加热控制, 极速升温。
Efficient heating controller, heating fast
3. 电子版可存储10个常用菜单, 可长期方便使用。
With 10 commonly menus in manual type oven for long-term use
4. 360度正反转热风加热, 温度无死角更均匀。
With 360 degrees hot air heating, make temperature more uniform
5. 手动或自动蒸汽喷雾功能保证足够的蒸汽量。
The steam boiler spray function ensures sufficient steam.



EOA-51F

热风电烤箱(带喷雾)5层

Convection Oven (With Spray)

型号	Model	EOA-51F
清洗功能	Cleaning	人工 Manual
容量	Capacity	600X400X25mmX5PCS
每天烹制份数	Output	30-80
纵向插槽	Pan size	600X400X25mm
长度	Width	817mm
宽度	Depth	771mm
高度	Height	782mm

进水口	Infall	R3/4"
出水口	Outfall	DN 25
水压	Water Pressure	150-600kPa或者0.6-3Mpa
重量	N/W	
设备功率	Hp	9kW
保险丝	Fuse	3*16A
电源连接	Volts	3NAC 380V





立式燃气六头煲仔炉连气焗炉
Gas Range With 6-Burner& Oven

型号	Model	BGH-997A	BGH-797A(700)
规格	Size	1200X900X930mm	1050X700X930mm
热功率	Hp	31.2kW	31.2kW
净重	Net Weight	200kg	175kg

立式燃气煲仔炉 Gas Range



立式燃气四头煲仔炉连烧烤炉连气焗炉
Gas Range With 4-Burner&Lava Rock Grill& Oven

型号	Model	BGH-999A	BGH-799A(700)
规格	Size	1200X900X930mm	1050X700X930mm
热功率	Hp	27kW	27kW
净重	Net Weight	205kg	175kg



立式燃气四头煲仔炉连扒炉连气焗炉
Gas Range With 4-Burner& Griddle& Oven

型号	Model	BGH-996A	BGH-796A(700)
规格	Size	1200X900X930mm	1050X700X930mm
热功率	Hp	30kW	30kW
净重	Net Weight	200kg	170kg

立式燃气煲仔炉 Gas Range



组合炉系列
Gas Combination Oven



立式燃气四头煲仔炉连气焗炉
Gas Range With 4-Burner & Gas Oven

型号	Model	BGH-987A
规格	Size	800X900X930mm
热功率	Hp	20.8kW
净重	Net Weight	143kg
型号	Model	BGH-787A(700)
规格	Size	700X700X930mm
热功率	Hp	20.8kW
净重	Net Weight	91kg



立式燃气扒炉连气焗炉1/3坑
Gas Griddle with & Gas Oven(1/3Grooved)

型号	Model	BGH-986A	BGH-786A(700)
规格	Size	800X900X930mm	700X700X930mm
热功率	Hp	20.8kW	20.8kW
净重	Net Weight	143kg	91kg



立式燃气四头煲仔炉连柜座
Gas Range With 4-Burner with Cabinet

型号	Model	BGH-987	BGH-787(700)
规格	Size	800X900X930mm	700X700X930mm
热功率	Hp	16kW	16kW
净重	Net Weight	143kg	91kg



立式燃气扒炉连柜座1/3坑
Gas Griddle with Cabinet(1/3Grooved)

型号	Model	BGH-986
规格	Size	800X900X930 mm
热功率	Hp	9.6kW
净重	Net Weight	138kg

型号	Model	BGH-786(700)
规格	Size	700X700X930mm
热功率	Hp	8.1kW
净重	Net Weight	81kg



立式燃气炸炉连柜座
Gas Fryer(2-Tank&2-Basket) With Cabinet

型号	Model	BGF-985	BGF-785(700)
规格	Size	800X900X930mm	700X700X930mm
热功率	Hp	32kW	32kW
容量	Capacity	30L/缸	20L/缸
净重	Net Weight	138kg	85kg



立式燃气火山石烧烤炉连柜座
Gas Lava Rock Grill with Cabinet

型号	Model	BGB-989	BGB-789(700)
规格	Size	800X900X930mm	700X700X930mm
热功率	Hp	12.4kW	12.4kW
净重	Net Weight	121kg	94kg



立式燃气汤池连柜座
Gas Bain Marie with Cabinet

型号	Model	BGH-984	BGH-784(700)
规格	Size	800X900X930mm	700X700X930mm
热功率	Hp	4.5KW	4.5KW
净重	Net Weight	75kg	53kg

立式燃气煮面炉连柜座
Gas Pasta Cooker with Cabinet

型号	Model	BGH-988	BGH-788(700)
规格	Size	800X900X930mm	700X700X930mm
热功率	Hp	12.4KW	12.4KW
净重	Net Weight	82kg	63kg



立式燃气可倾斜式炒锅
Gas Tilting Braising Pan

型号	Model	BGH-980	BGH-780
规格	Size	800X900X930mm	800X700X930mm
热功率	Hp	12kW	9.5kW
容量	Capacity	80L	60L
净重	Net Weight	140kg	120kg



立式燃气夹层汤锅
Gas Soup Kettle

型号	Model	BGH-981	BGH-781
规格	Size	800X900X930mm	800X700X930mm
热功率	Hp	24kW	16kW
容量	Capacity	100L	60L
净重	Net Weight	140kg	120kg



立式电磁四头煮食炉连电焗炉
Freestanding 4 Burner Induction Cooker With Oven

型号	Model	BEH-887D
规格	Size	800X900X930mm
功率	Hp	3.5kW x 4+4.8kW
电压	Volt	3N~380V
净重	Net Weight	80kg

立式电热六头煮食炉连电焗炉
Electric Range With 6-Hot Plate & Oven

型号	Model	BEH-897A 方板
规格	Size	1200X900X930mm
功率	Hp	4kW x 6+4.8kW
电压	Volt	3N~380V
净重	Net Weight	140kg



立式电热四头煮食炉连电焗炉
Electric Range With 4-Hot Plate & Oven

型号	Model	BEH-887A
规格	Size	800X900X930mm
功率	Hp	4kW x 4+4.8kW
电压	Volt	3N~380V
净重	Net Weight	80kg



立式电热四头煮食炉连柜座
Electric Range With 4-Hot Plate & Cabinet

型号	Model	BEH-887
规格	Size	800X900X930mm
功率	Hp	16kW
电压	Volt	3N~380V
净重	Net Weight	80kg



电热煮食炉 Electric Range



立式电热四头煮食炉连电焗炉
Electric Range With 4-Hot Plate & Oven

型号	Model	BEH-887B
规格	Size	800X900X930mm
功率	Hp	2kWx2+2.6kWx2+4.8kW
电压	Volt	3N~380V
净重	Net Weight	80kg



立式电热四头煮食炉连电焗炉
Electric Range With 4-Hot Plate & Oven

型号	Model	BEH-787B
规格	Size	700X700X930mm
功率	Hp	2kWx2+2.6kWx2+4.8kW
电压	Volt	3N~380V
净重	Net Weight	80kg



立式电热四头煮食炉连柜座
Electric Range With 4-Hot Plate & Cabinet

型号	Model	BEH-887C	BEH-787C
规格	Size	800X900X930mm	700X700X930mm
功率	Hp	2kWx2+2.6kWx2	2kWx2+2.6kWx2
电压	Volt	3N~380V	3N~380V
净重	Net Weight	80kg	80kg



组合方系列
Combination Oven



立式电扒炉连柜座1/3坑
Electric Griddle with Cabinet(1/3Grooved)

型号	Model	BEG-886(900)	BEG-786(700)
规格	Size	800X900X930mm	700X700X930mm
功率	Hp	8.1kW	8.1kW
电压	Volt	3N~380V	3N~380V
净重	Net Weight	118kg	82kg



立式电双缸炸炉连柜座
Electric Fryer(2-Tank&2-Basket) with Cabinet

型号	Model	BDF-885(900)	BDF-785(700)
规格	Size	800X900X930mm	700X700X930mm
功率	Hp	9+9kW	9+9kW
电压	Volt	3N~380V	3N~380V
容量	Capacity	30L/缸	20L/缸
净重	Net Weight	72kg	65kg



立式电热火山石烧烤炉连柜座
Electric Lava Rock Grill with Cabinet

型号	Model	BEB-889(900)	BEB-789(700)
规格	Size	800X900X930mm	700X700X930mm
功率	Hp	8.1kW	8.1kW
电压	Volt	3N~380V	3N~380V
净重	Net Weight	115kg	95kg



立式电热汤池连柜座
Electric Bain Marie with Cabinet

型号	Model	BEH-884	BEH-784(700)
规格	Size	800X900X930mm	700X700X930mm
功率	Hp	9kW	9kW
电压	Volt	3N~380V	3N~380V
净重	Net Weight	68.5kg	60kg

立式电煮面炉连柜座
Electric Pasta Cooker with Cabinet

型号	Model	BEH-888	BEH-788(700)
规格	Size	800X900X930mm	700X700X930mm
功率	Hp	18kW	18kW
电压	Volt	3N~380V	3N~380V
净重	Net Weight	75.5kg	63kg



电热可倾斜式炒锅
Electric Tilting Braising Pan

型号	Model	BEH-880(900)	BEH-780(700)
规格	Size	800X900X930mm	800X700X930mm
功率	Hp	10.2kW	9kW
电压	Volt	3N~380V	3N~380V
容量	Capacity	80L	60L
净重	Net Weight	140kg	120kg



电热夹层汤锅
Electric Gas Soup Kettle

型号	Model	BEH-881(900)	BEH-781(700)
规格	Size	800X900X930mm	800X700X930mm
功率	Hp	18kW	12kW
电压	Volt	3N~380V	3N~380V
容量	Capacity	100L	60L
净重	Net Weight	140kg	120kg



BGF-975
BGF-775(700)



BGH-974
BGH-774Z(700)



BGH-978
BGH-778(700)

立式燃气炸炉连柜座
Gas Fryer(1-Tank&1-Basket) With Cabinet

立式燃气汤池炉连柜座
Gas Bain Marie With Cabinet

立式燃气煮面炉连柜座
Gas Pasta Cooker With Cabinet

型号	Model	BGF-975	BGF-775(700)	BGH-974	BGH-774Z(700)	BGH-978	BGH-778(700)
规格	Size	400X900X930	400X700X930	400X900X930	400X700X930	400X900X930	400X700X930
热功率	Hp	16KW	16KW	2.4KW	2.4KW	6.2KW	6.2KW
容量	Capacity	28L/缸	28L/缸				
净重	Net Weight	52kg	48kg	43kg	42kg	48kg	42kg



BGH-977
BGH-777(700)



BGB-979
BGB-779(700)



BGH-976
BGH-776Z(700)

立式燃气二头煲仔炉连气焗炉
Gas Range With 2-Burner & Gas Oven

立式燃气火山石烧烤炉连柜座
Gas Lava Rock Grill with Cabinet

立式燃气扒炉连柜座
Gas Griddle with Cabinet

型号	Model	BGH-977	BGH-777(700)	BGB-979	BGB-779(700)	BGH-976	BGH-776Z(700)
规格	Size	400X900X930	400X700X930	400X900X930	400X700X930	400X900X930	400X700X930
热功率	Hp	8KW	8KW	6.2KW	6.2KW	4.8KW	4.8KW
净重	Net Weight	45kg	42kg	77kg	68kg	63kg	58kg



BDF-875
BDF-775(700)



BEH-874Z
BEH-774Z(700)



BEH-876Z
BEH-776Z(700)

立式电热28L炸炉连柜座
Electric Fryer(1-Tank&1-Basket) With Cabinet

立式电热汤池炉连柜座
Electric Bain Marie With Cabinet

立式电热煮面炉连柜座
Electric Pasta Cooker With Cabinet

型号 Model	BDF-875	BDF-775(700)	BEH-874Z	BEH-774Z(700)	BEH-876Z	BEH-776Z(700)
规格 Size	400X900X930	400X700X930	400X900X940	400X700X940	400X900X940	400X700X940
功率 Hp	9kW	9kW	380V	380V	380V	380V
电压 Volt	3N~380V	3N~380V	3kW	3kW	9kW	9kW
净重 Net Weight	52kg	28L/缸	48kg	42kg	48kg	42kg



BEH-877(方)
BEH-777(圆)



BEB-879
BEB-779(700)



BEH-876Z
BEH-776Z(700)

立式电热二头煮食炉连柜座
Electric Range With 2-Hot Plate&Cabinet

立式电热火山石烧烤炉连柜座
Electric Lava Rock Grill with Cabinet

立式电热扒炉连柜座
Electric Griddle with Cabinet

型号 Model	BEH-877(方)	BEH-777(圆)	BEB-879	BEB-779(700)	BEH-876Z	BEH-776Z(700)
规格 Size	400X900X930	400X700X930	400X900X940	400X700X940	400X900X940	400X700X940
功率 Hp	4kW+4kW	2kW+2.6kW	380V	380V	380V	380V
电压 Volt	3N~380V	3N~380V	5.4kW	5.4kW	4.1kW	4.1kW
净重 Net Weight	63kg	58kg	77kg	68kg	63kg	58kg



台式燃气煲仔炉
Counter Top Gas Stove

型号	Model	BGH-587
规格	Size	600X630X440mm
热功率	Hp	16kW
净重	Net Weight	45kg



台式燃气扒炉
Counter Top Gas Griddle

型号	Model	BGH-586
规格	Size	600X630X440mm
热功率	Hp	8.2kW
净重	Net Weight	43kg



台式燃气双缸双筛炸炉
Counter Top Gas Fryer

型号	Model	BGF-585
规格	Size	600X630X440mm
热功率	Hp	5.6kW
容量	Capacity	8L/缸
净重	Net Weight	25kg



台式燃气火山石烧烤炉
Counter Top Gas Lava Rock Grill

型号	Model	BGB-589
规格	Size	600X630X440mm
热功率	Hp	8.2kW
净重	Net Weight	50kg



台式燃气四盆汤池
Counter Top Gas Bain Marie

型号	Model	BGH-584
规格	Size	700X630X440mm
热功率	Hp	4.2kW
净重	Net Weight	29kg



台式燃气六头煮面炉
Counter Top Gas Pasta Cooker

型号	Model	BGH-588
规格	Size	600X630X440mm
热功率	Hp	6kW
净重	Net Weight	25kg



台式电热火山石烧烤炉
Counter Top Electric Lava Rock Grill

型号	Model	BEB-689
规格	Size	600X600X340mm
电压	Volt	220V
功率	Hp	5.6kW
净重	Net Weight	36kg



台式双缸双筛电炸炉
Counter Top Electric Fryer
(2-Tank & 2-Basket)

型号	Model	BDF-685
规格	Size	600X600X340mm
功率	Hp	2.8+2.8kW
电压	Volt	220V
容量	Capacity	8L+8L/缸
净重	Net Weight	18kg



台式四盆电热汤池
Counter Top Electric Bain Marie

型号	Model	BEH-684
规格	Size	700X600X340mm
电压	Volt	220V
功率	Hp	1.5kW
净重	Net Weight	18kg



台式电热煮食炉
Counter Top Electric 4-plate Cooker

型号	Model	BEH-687
规格	Size	600X600X340mm
电压	Volt	220V
功率	Hp	7kW
净重	Net Weight	18.5kg



台式电热平扒炉(全平)
Counter Top Electric Griddle(flat)

型号	Model	BEG-686
规格	Size	600X600X340mm
电压	Volt	220V
功率	Hp	5.6kW
净重	Net Weight	30kg



台式电热煮面炉
Counter Top Electric Pasta Cooker

型号	Model	BEH-688
规格	Size	600X600X340mm
电压	Volt	220V
功率	Hp	6kW
净重	Net Weight	20kg



台式电热火山石烧烤炉
Counter Top Electric Lava Rock Grill

型号	Model	BEB-669
规格	Size	600X650X480mm
电压	Volt	3N~380V
功率	Hp	5.6kW
净重	Net Weight	36kg



台式电热煮食炉
Counter Top Electric 4-plate Cooker

型号	Model	BEH-667
规格	Size	600X650X480mm
电压	Volt	3N~380V
功率	Hp	9.2kW
净重	Net Weight	18.5kg



台式电热平扒炉(全平)
Counter Top Electric Griddle(flat)

型号	Model	BEG-666
规格	Size	600X650X480mm
电压	Volt	3N~380V
功率	Hp	5.6kW
净重	Net Weight	51kg



台式四盆电热汤池
Counter Top Electric Bain Marie

型号	Model	BEH-664
规格	Size	600X650X480mm
电压	Volt	220V
功率	Hp	1.5kW
净重	Net Weight	18kg



台式双缸双筛电炸炉
Counter Top Electric Fryer(2-Tank& 2-Basket)

型号	Model	BDF-665	BDF-665A
规格	Size	600X650X480mm	600X650X480mm
功率	Hp	8.5kW+8.5kW	4.5kW+4.5kW
电压	Volt	3N~380V	3N~380V
容量	Capacity	12L+12L/缸	12L+12L/缸
净重	Net Weight	18kg	18kg



台式电热煮面炉
Counter Top Electric Pasta Cooker

型号	Model	BEH-668
规格	Size	600X650X480mm
电压	Volt	3N~380V
功率	Hp	6kW
净重	Net Weight	20kg



台式电热火山石烧烤炉
Counter Top Electric Lava Rock Grill

型号	Model	BEB-649
规格	Size	400X650X480mm
电压	Volt	220V
功率	Hp	2.8kW
净重	Net Weight	36kg



台式电热煮食炉
Counter Top Electric 4-plate Cooker

型号	Model	BEH-647
规格	Size	400X650X480mm
电压	Volt	220V
功率	Hp	4.6kW
净重	Net Weight	13kg



台式电热平扒炉(全平)
Counter Top Electric Griddle(flat)

型号	Model	BEG-646
规格	Size	400X650X480mm
电压	Volt	220V
功率	Hp	2.8kW
净重	Net Weight	36kg



台式二盆电热汤池
Counter Top Electric Bain Marie

型号	Model	BEH-644
规格	Size	400X650X480mm
电压	Volt	220V
功率	Hp	1.5kW
净重	Net Weight	18.6kg



台式单缸单筛电炸炉
Counter Top Electric Fryer(1-Tank& 1-Basket)

型号	Model	BDF-645	BDF-645A
规格	Size	400X650X480mm	400X650X480mm
功率	Hp	8.5kW	4.5kW
电压	Volt	220V	220V
容量	Capacity	12L/缸	12L/缸
净重	Net Weight	12.6kg	12.6kg



台式电热煮面炉
Counter Top Electric Pasta Cooker

型号	Model	BEH-648
规格	Size	400X650X480mm
电压	Volt	220V
功率	Hp	3kW
净重	Net Weight	14kg

日式铁板烧



铁板烧款式、规格、出风口位置、均可订制
设备内部可选择安装抽风机、净化器



1米日式电磁铁板烧
1M Japanese-style Electric Teppanyaki Machine

型号	Model	BEH-1M
规格	Size	1000X800X800mm
功率	Hp	8kW
电压	Volt	3N~380V
净重	Net Weight	150kg

1.2米日式电磁铁板烧
1.2M Japanese-style Electric Teppanyaki Machine

型号	Model	BEH-12M
规格	Size	1200X800X800mm
功率	Hp	8kW
电压	Volt	3N~380V
净重	Net Weight	200kg

1.5米日式电磁铁板烧
1.5M Japanese-style Electric Teppanyaki Machine

型号	Model	BEH-15M
规格	Size	1500X800X800mm
功率	Hp	8kW
电压	Volt	3N~380V
净重	Net Weight	250kg

日式燃气铁板烧



1米日式铁板烧

1M Japanese-style Gas Teppanyaki Machine

1.2米日式铁板烧

1.2M Japanese-style Gas Teppanyaki Machine

1.5米日式铁板烧

1.5M Japanese-style Gas Teppanyaki Machine

型号	Model	BGH-1A	BGH-12A	BGH-15A
规格	Size	1000X800X800mm	1200X800X800mm	1500X800X800mm
热功率	Hp			
气源	Gas Source	低压液化石油气 (LPG)	低压液化石油气 (LPG)	低压液化石油气 (LPG)
净重	Net Weight	150kg	200kg	250kg



1米日式电热铁板烧

1M Japanese-style Electric Teppanyaki Machine

型号	Model	BEG-1M
规格	Size	1000X800X800mm
功率	Hp	8kW/12kW
电压	Volt	3N~380V
净重	Net Weight	150kg

1.2米日式电热铁板烧

1.2M Japanese-style Electric Teppanyaki Machine

型号	Model	BEG-12M
规格	Size	1200X800X800mm
功率	Hp	8kW/12kW
电压	Volt	3N~380V
净重	Net Weight	200kg

1.5米日式电热铁板烧

1.5M Japanese-style Electric Teppanyaki Machine

型号	Model	BEG-15M
规格	Size	1500X800X800mm
功率	Hp	8kW/12kW/16kW
电压	Volt	3N~380V
净重	Net Weight	250kg





西式快餐系列

Western Fast Food Series





立式薯条工作站
Free standing Chips Warmer

型号	Model	BVF-9
规格	Size	600X700X1500mm
功率	Hp	0.75kW
电压	Volt	220V
净重	Net Weight	38kg



立式薯条工作站
Free standing Chips Warmer

型号	Model	BVF-10
规格	Size	1000X700X1570mm
功率	Hp	1kW
电压	Volt	220V
净重	Net Weight	52kg



BVF-8 BVF-6

台式薯条工作站
Counter Top Chips Warmer

型号	Model	BVF-8	BVF-6
规格	Size	800X710X650mm	600X700X650mm
功率	Hp	0.5kW	0.5kW
电压	Volt	220V	220V
净重	Net Weight	27.5kg	17kg



BDH-310

食物保温站
Hot Showcase

型号	Model	BDH-310
规格	Size	330X560X500mm
功率	Hp	1kW
电压	Volt	220V
净重	Net Weight	7.4kg



BVF-4

薯条漏油斗
Chips Scuttle Oil Filter

型号	Model	BVF-4
规格	Size	440X580X185mm



西式快餐 Western Fast Food



BDL-2621

立式烘汉堡包机
Electric Bun Toaster

型号	Model	BDL-2621
规格	Size	540X274X587mm
功率	Hp	1.6kW
电压	Volts	220V
净重	Net Weight	20kg



BGF-312



BGF-211



BGF-212

烘汉堡包机
Electric Bun Toaster

型号	Model	BGF-211	BGF-212	BGF-312
规格	Size	420X390X260mm	420X700X260mm	420X700X350mm
功率	Hp	0.8kW	2kW	4kW
电压	Volts	220V	220V	220V
净重	Net Weight	17kg	26kg	39kg



BGW-800
BGW-1000

裹粉台
Manual Breeding Table

型号	Model	BGW-800	BGW-1000	BGW-1000B
规格	Size	800X700X800(950)mm	1000X700X800(950)mm	1000X700X800(950)mm
功率	Hp			
电压	Volt			
净重	Net Weight	25kg	27.5kg	27.5kg



BLU-400

拆装式裹粉台
Manual Breeding Table



BLU-330

滤油车
Oil Filter Cart

型号	Model	BLU-400	BLU-330
规格	Size	800X450X760mm	340X600X650mm
功率	Hp	0.37kW	0.25kW
电压	Volt	220V	220V
净重	Net Weight	42kg	32kg



腌制机
Marinated Machine

型号	Model	BYA-900
规格	Size	953X660X914mm
功率	Hp	0.38kW
电压	Volts	220V
净重	Net Weight	29kg



真空腌制机
Vacuum Marinated Machine

型号	Model	BYA-908
规格	Size	953X660X914mm
功率	Hp	0.5kW
电压	Volts	220V
净重	Net Weight	41kg



腌制机
Marinated Machine

型号	Model	BYA-4C
规格	Size	780X460X850mm
功率	Hp	0.2kW
电压	Volts	220V
净重	Net Weight	29kg



电脑版腌制机
Marinated Machine

型号	Model	BYA-4A
规格	Size	780X460X850mm
功率	Hp	0.4kW
电压	Volts	220V
净重	Net Weight	29kg



陈列保温柜
Electric Food Warmer

型号	Model	BDH-5P
规格	Size	1800X760X860mm
功率	Hp	3.6kW
电压	Volt	220V

陈列保温柜
Electric Food Warmer

型号	Model	BDH-4P
规格	Size	2200X760X860mm
功率	Hp	3.6kW
电压	Volt	220V



陈列保温柜
Electric Food Warmer

型号	Model	BDH-6P
规格	Size	1500X760X860mm
功率	Hp	2.7kW
电压	Volt	220V
净重	Net Weight	69kg

陈列保温柜
Electric Food Warmer

型号	Model	BDH-8P
规格	Size	1200X760X860mm
功率	Hp	2.7kW
电压	Volt	220V
净重	Net Weight	59kg



陈列直角保温柜
Electric Food Warmer

型号	Model	BDH-6P-A
规格	Size	1500X760X860mm
功率	Hp	2.7kW
电压	Volt	220V



双层陈列保温柜
Electric Display Showcase

型号	Model	BDH-2X4
规格	Size	1200X640X730mm
功率	Hp	1.4kW
电压	Volt	220V
净重	Net Weight	43kg

西式快餐
Western Fast Food



双层陈列保温柜
Electric Display Showcase

型号	Model	BDH-2X3
规格	Size	1000X640X730mm
功率	Hp	1.4kW
电压	Volt	220V
净重	Net Weight	35kg



双层陈列保温柜
Electric Display Showcase

型号	Model	BDH-2X2
规格	Size	700X640X730mm
功率	Hp	0.7kW
电压	Volt	220V
净重	Net Weight	



Center Island

中心岛
 型号 Model: BWS-12
 规格 Size: 1500X1100X780mm
 净重 Net weight: 70kg



Center Island

中心岛
 型号 Model: BWS-02
 规格 Size: 1500X760X780mm



Center Island

中心岛
 型号 Model: BWS-01
 规格 Size: 1200X760X780mm



Center Island

中心岛
 型号 Model: BWS-2
 规格 Size: 775X1100X780mm
 净重 Net weight: 38kg



BDF-26-2A



BDF-26-2

特性：使用不锈钢高效发热线，升温快，及时补偿油炸时的降温，保证油炸的品质；电脑板带10段产品油炸功能，提醒功能，实现标准化管理的操作。

立式板双缸四筛炸炉(带计时器)
Vertical 2-Tank Fryer (4-Basket) With Timer

型号	Model	BDF-26-2A
规格	Size	800X800X1125mm
功率	Hp	9kW+9kW/18kW+18kW
电压	Volt	3N~380V
容量	Capacity	30L+30L

立式双缸四筛电炸炉
Electric 2-Tank Fryer (4-Basket)

型号	Model	BDF-26-2
规格	Size	800X800X1090mm
功率	Hp	9kW+9kW/18kW+18kW
电压	Volt	3N~380V
容量	Capacity	30L+30L
净重	Net Weight	70kg



BDF-32A
BDF-30A



BDF-30-2A
BDF-30-2

立式电脑单缸双筛电炸炉(连滤油车)
Vertical 1-Tank Computer Fryer with Oil Filter Cart(2-Basket)

型号	Model	BDF-30A
规格	Size	400X800X1125mm
功率	Hp	9kW/18kW
电压	Volt	3N~380V
容量	Capacity	30L/缸

特性：使用不锈钢高效发热线，升温快，及时补偿油炸时的降温，保证油炸的品质；电脑板带10段产品油炸功能，提醒功能，实现标准化管理的操作。

立式电脑板双缸双筛电炸炉(连滤油车)
Vertical 2-Tank Computer Fryer (2-Basket)

型号	Model	BDF-32A
规格	Size	400X800X1125mm
功率	Hp	6kW+6kW
电压	Volt	3N~380V
容量	Capacity	14L+14L/缸

特性：使用不锈钢高效发热线，升温快，及时补偿油炸时的降温，保证油炸的品质；电脑板带10段产品油炸功能，提醒功能，实现标准化管理的操作。

定制立式电脑板双缸四筛电炸炉(连滤油车)
Vertical 2-Tank Computer Fryer with Oil Filter Cart(4-Basket)

定制立式电脑板双缸四筛电炸炉(连滤油车)
Vertical 2-Tank Computer Fryer with Oil Filter Cart(4-Basket)

型号	Model	BDF-30-2A
规格	Size	800X800X1090mm
功率	Hp	18kW+18kW
电压	Volt	3N~380V
容量	Capacity	30L+30L
净重	Net Weight	70kg

特性：使用不锈钢高效发热线，升温快，及时补偿油炸时的降温，保证油炸的品质。电脑板带10段产品油炸功能，提醒功能，全自动滤油功能；节省成本，实现标准化管理的操作。

立式电脑板双缸四筛电炸炉(连滤油车)
Vertical 2-Tank Computer Fryer with Oil Filter Cart (4-Basket)

型号	Model	BDF-30-2
规格	Size	800X800X1125mm
功率	Hp	9kW+9kW
电压	Volt	3N~380V
容量	Capacity	30L+30L

特性：使用不锈钢高效发热线，升温快，及时补偿油炸时的降温，保证油炸的品质；电脑板带10段产品油炸功能，提醒功能，实现标准化管理的操作。





立式电脑单缸双筛炸炉

Vertical 1-Tank Computer Fryer (2-Basket)

型号	Model	BDF-30
规格	Size	400X800X1125mm
功率	Hp	9kW/18kW
电压	Volt	3N~380V
容量	Capacity	30L/缸
净重	Net Weight	40kg

特性：使用不锈钢高效发热线，升温快，及时补偿油炸时的降温，保证油炸的品质；电脑板带10段产品油炸功能，提醒功能，实现标准化管理的操作。

立式电脑板双缸双筛电炸炉

Vertical 2-Tank Computer Fryer (2-Basket)

型号	Model	BDF-32
规格	Size	400X800X1125mm
功率	Hp	6kW+6kW
电压	Volt	3N~380V
容量	Capacity	14L+14L/缸

特性：使用不锈钢高效发热线，升温快，及时补偿油炸时的降温，保证油炸的品质。电脑板带10段产品油炸功能，提醒功能，实现标准化管理的操作。



BDF-26A



BDF-26



BDF-28



立式单缸双筛电炸炉 (带计时器)
Electric 1-Tank Fryer (2-Basket) With Time

型号	Model	BDF-26A
规格	Size	400X800X1090mm
功率	Hp	9kW/18kW
电压	Volt	3N~380V
容量	Capacity	30L
净重	Net Weight	35kg

立式单缸双筛电炸炉
Electric 1-Tank Fryer (2-Basket)

型号	Model	BDF-26
规格	Size	400X800X1125mm
功率	Hp	9kW/18kW
电压	Volt	3N~380V
容量	Capacity	30L
净重	Net Weight	35kg

立式双缸双筛电炸炉
Electric 2-Tank Fryer (2-Basket)

型号	Model	BDF-28
规格	Size	400X800X1125
功率	Hp	6kW+6kW
电压	Volt	3N~380V
容量	Capacity	14L+14L/缸
净重	Net Weight	40kg



BDF-84



BDF-85

立式单缸双筛电炸炉

Electric 1-Tank Fryer (2-Basket)

型号	Model	BDF-84
规格	Size	570X510X960
功率	Hp	4kW+4kW
电压	Volt	220V
容量	Capacity	27L/缸
净重	Net Weight	23kg

立式双缸双筛电炸炉

Electric 2-Tank Fryer (2-Basket)

型号	Model	BDF-85
规格	Size	590X510X960
功率	Hp	4kW+4kW
电压	Volt	220V
容量	Capacity	14+14L/缸
净重	Net Weight	26kg



电炸炉
Electric Gas Fryer



BGF-74



BGF-75

立式单缸双筛炸炉

Gas 1-Tank Fryer (2-Basket)

型号	Model	BGF-74
规格	Size	570X510X970mm
热功率	Hp	5.6kW
气源	Gas Source	低压液化石油气 (LPG)
容量	Capacity	27L/缸
净重	Net Weight	23kg

立式燃气双缸双筛炸炉

Gas 2-Tank Fryer (2-Basket)

型号	Model	BGF-75
规格	Size	570X510X970mm
热功率	Hp	5.6kW
气源	Gas Source	低压液化石油气 (LPG)
容量	Capacity	14L+14L/缸
净重	Net Weight	23kg





带控温、限温器。
加热速度：30° -180°
18分钟

40L 燃气交叉管炸炉
Gas 1-Tank Fryer

型号	Model	BGF-40L	适用于液化气和天然气，电子打火，自动控温，带熄火保护功能
规格	Size	550X600X1000mm	容量：40L
热功率	Hp	5.6kW	加热速度：19° -180°，24分钟
容量	Capacity	40L	
净重	Net Weight	23kg	

40L 发热管后翻转电炸炉
Electric 1-Tank Fryer

型号	Model	BDF-40LE	
规格	Size	550X600X970	
功率	Hp	9kW	6kW
电压	Volt	3N~380V	220V
容量	Capacity	40L	
净重	Net Weight	23kg	



台式燃气控温炸炉
Gas Temperature-controlled Fryer

型号	Model	BCH-17L
规格	Size	500X600X440mm
热功率	Hp	
容量	Capacity	17L
净重	Net Weight	23kg

适用于液化气和天然气，电子打火，自动控温，加热速度：15° -180°，19分钟

台式单缸控温电炸炉
Gas Temperature-controlled Fryer

型号	Model	BEF-17L
规格	Size	500X640X380
功率	Hp	5kW
电压	Volt	220V/50Hz
容量	Capacity	17L
净重	Net Weight	23kg

带控温、限温器。
加热速度：30° -180°，18分钟



欧式单缸单筛电炸炉
Electric Fryer(1-Tank& 1-Basket)

欧式双缸双筛电炸炉
Electric Fryer(2-Tank& 2-Basket)

欧式单缸单筛电炸炉
Electric Fryer(1-Tank& 1-Basket)

型号	Model	BDF-131V	BDF-132V	BDF-301V
规格	Size	310X510X370mm	630X510X370mm	630X510X370mm
功率	Hp	4.5kW	4.5kW+4.5kW	6kW
电压	Volt	220V	220V	220V
容量	Capacity	13L	13L+13L	30L
净重	Net Weight	8.3kg	15kg	15kg



欧式单缸单筛电炸炉
Electric Fryer(1-Tank& 1-Basket)

欧式双缸双筛电炸炉
Electric Fryer(2-Tank& 2-Basket)

欧式单缸单筛电炸炉
Electric Fryer(1-Tank& 1-Basket)

型号	Model	BDF-101V	BDF-102V	BDF-201V
规格	Size	280X500X350mm	570X500X350mm	590X520X350mm
功率	Hp	3kW	3kW+3kW	4.8kW
电压	Volt	220V	220V	220V
容量	Capacity	10L	10L+10L	20L
净重	Net Weight	8kg	13kg	13kg



电脑版台式单缸单筛电炸炉
Counter Top Electric Fryer(1-Tank& 1-Basket)

型号	Model	BDF-101AV
规格	Size	280X470X350mm
功率	Hp	3kW
电压	Volt	220V
容量	Capacity	8L/缸
净重	Net Weight	10kg

电脑版台式双缸双筛电炸炉
Counter Top Electric Fryer(2-Tank& 2-Basket)

型号	Model	BDF-102AV
规格	Size	570X470X350mm
功率	Hp	3kW+3kW
电压	Volt	220V
容量	Capacity	8L
净重	Net Weight	18kg



BDF-903



BDF-904

台式单缸单筛电炸炉
Counter Top Electric 1-Tank Fryer(1-Basket)

型号 Model	BDF-903
规格 Size	330X600X435mm
功率 Hp	4.5kW
电压 Volt	220V
容量 Capacity	15L/缸
净重 Net Weight	11kg

台式双缸双筛电炸炉
Counter Top Electric Fryer(2-Tank& 2-Basket)

型号 Model	BDF-904
规格 Size	660X600X435mm
功率 Hp	4.5kW+4.5kW
电压 Volt	220V
容量 Capacity	15L+15L
净重 Net Weight	22kg

电炸炉 Fryer



BDF-12L
BDF-10L



BDF-12L-2
BDF-10L-2

台式单缸单筛电炸炉
Counter Top Electric 1-Tank Fryer(1-Basket)

型号 Model	BDF-10L	BDF-12L
规格 Size	290X550X310mm	290X550X360mm
功率 Hp	2.8KW	2.8KW
电压 Volt	220V	220V
容量 Capacity	6L/缸	8L/缸
净重 Net Weight	10.5kg	11kg

台式双缸双筛电炸炉
Counter Top Electric Fryer(2-Tank& 2-Basket)

型号 Model	BDF-10L-2	BDF-12L-2
规格 Size	580X550X360mm	580X550X360mm
功率 Hp	2.8kW+2.8kW	2.8kW+2.8kW
电压 Volt	220V	220V
容量 Capacity	6L+6L	8L+8L
净重 Net Weight	21kg	22kg



BDF-6L
BDF-8L



BDF-6L-2
BDF-8L-2

台式单缸单筛电炸炉
Counter Top Electric 1-Tank Fryer(1-Basket)

型号 Model	BDF-8L	BDF-6L
规格 Size	265X425X280mm	265X425X230mm
功率 Hp	2.8kW	2.5kW
电压 Volt	220V	220V
容量 Capacity	8L/缸	6L/缸
净重 Net Weight	5.5kg	4.5kg

台式双缸双筛电炸炉
Counter Top Electric Fryer(2-Tank& 2-Basket)

型号 Model	BDF-8L-2	BDF-6L-2
规格 Size	530X425X280mm	530X425X230mm
功率 Hp	2.8kW+2.8kW	2.5kW+2.5kW
电压 Volt	220V	220V
容量 Capacity	8L+8L	6L+6L
净重 Net Weight	10kg	8.5kg

台式炸炉 Fryer



台式单缸双筛电炸炉
Counter Top Electric Fryer
(1-Tank & 2-Basket)

型号	Model	BDF-18
规格	Size	350X640X310mm
功率	Hp	3kW
电压	Volt	220V
容量	Capacity	12L
净重	Net Weight	8kg

台式单缸双筛电炸炉
Counter Top Electric Fryer
(1-Tank & 2-Basket)

型号	Model	BDF-83
规格	Size	580X460X310mm
功率	Hp	2.5kW+2.5kW
电压	Volt	220V
容量	Capacity	12L
净重	Net Weight	9kg



BDF-18



BDF-83



台式双缸双筛电炸炉
Counter Top Electric Fryer
(2-Tank & 2-Basket)

型号	Model	BDF-82(82A带限温器)
规格	Size	580X460X310mm
功率	Hp	2.5kW+2.5kW
电压	Volt	220V
容量	Capacity	6L+6L
净重	Net Weight	9kg

BDF-82
BDF-82A

台式单缸单筛电炸炉
Counter Top Electric Fryer
(1-Tank & 1-Basket)

BDF-4A	BDF-81/(81A带限温器)
180X410X290mm	290X460X310mm
2kW	2.5kW
220V	220V
4L	6L
3kg	4.5kg

BDF-81
BDF-81A



BDF-4A



燃气单缸单筛炸炉
Gas 1-Tank Fryer (1-Basket)

型号	Model	BGF-71
规格	Size	290X520X460mm
热功率	Hp	5.6kW
气源	Gas Source	低压液化石油气(LPG)
容量	Capacity	6L/缸
净重	Net Weight	9.5kg

BGF-71



BGF-72

台式燃气双缸双筛炸炉
Gas 2-Tank Fryer (2-Basket)

型号	Model	BGF-72
规格	Size	580X520X460mm
热功率	Hp	5.6kW
气源	Gas Source	低压液化石油气(LPG)
容量	Capacity	6L+6L
净重	Net Weight	20kg



电脑版 豪华煎饺子机

Fried Dumpling Machine



不锈钢煎板

电脑版煎饺子机
Fried Dumpling Machine

型号	Model	BEG-11A-2
规格	Size	600X600X430mm
功率	Hp	3.2kW+3.2kW
电压	Volt	220V
净重	Net Weight	32kg

不锈钢煎板

豪华电脑版煎饺子机
Fried Dumpling Machine

型号	Model	BEG-11A
规格	Size	300X600X450mm
功率	Hp	3.2kW
电压	Volt	220V
净重	Net Weight	23kg



不锈钢煎板

电子版煎饺子机
Fried Dumpling Machine

型号	Model	BEG-12
规格	Size	300X600X430mm
功率	Hp	3.2kW
电压	Volt	220V
净重	Net Weight	15kg



不锈钢煎板

豪华燃气煎饺子机
Gas Fried Dumpling Machine

型号	Model	BEG-13
规格	Size	300X600X430mm
功率	Hp	2.8kW
气源	Gas Source	低压液化石油气 (LPG/NG)
净重	Net Weight	15kg

电热火山石 烧烤炉

Electric Lava Rock Grill



电热火山石烧烤炉
Electric Lava Rock Grill

型号	Model	BEG-48H	BEG-36H	BEG-24H
规格	Size	1200X616X406mm	914X616X406mm	609X616X406mm
功率	Hp	16kW	12kW	8kW
电压	Volt	3N~380V	3N~380V	3N~380V
净重	Net Weight	80kg	70kg	51kg



扒炉 Electric Griddle



电平扒炉
Electric Griddle (Flat plate)

型号	Model	BEG-48
规格	Size	1200X616X406mm
功率	Hp	16kW
电压	Volt	3N~380V
净重	Net Weight	80kg



电平扒炉
Electric Griddle (Flat plate)

型号	Model	BEG-36
规格	Size	914X616X406mm
功率	Hp	12kW
电压	Volt	3N~380V
净重	Net Weight	70kg

电平扒炉
Electric Griddle (Flat plate)

型号	Model	BEG-24
规格	Size	609X616X406mm
功率	Hp	8kW
电压	Volt	3N~380V
净重	Net Weight	51kg



电半平半坑扒炉

Electric Griddle (2/3 Flat & 1/3 Grooved)

型号	Model	BEG-822
规格	Size	730X500X230mm
电压	Volt	220V
功率	Hp	4.4kW
净重	Net Weight	33kg

电平扒炉

Electric Griddle (Flat plate)

型号	Model	BEG-820
规格	Size	730X500X230mm
电压	Volt	220V
功率	Hp	4.4kW
净重	Net Weight	33kg



电平扒炉连炸炉

Electric Griddle (Flat plate)

型号	Model	BEG-830
规格	Size	730X500X230mm
电压	Volt	220V
功率	Hp	4.7kW
净重	Net Weight	24kg



台式电热平扒炉(全平)

Counter Top Electric Griddle(flat)

型号	Model	BEG-818	BEG-818A	BEG-818B
规格	Size	550X400X230mm	550X450X230mm	350X400X230mm
电压	Volt	220V	220V	220V
功率	Hp	3kW	3kW	1.5kW
净重	Net Weight	16kg	17kg	11kg

热气火山石 烧烤炉

Gas Lava Rock Grill



燃气火山石烧烤炉
Gas Lava Rock Grill

型号	Model	BGH-48H	BGH-36H	BGH-24H
规格	Size	1200X660X480mm	900X660X480mm	600X660X480mm
热功率	Hp	18kW	13.5kW	9kW
气源	Gas Source	低压液化石油气 (LPG/NG)	低压液化石油气 (LPG/NG)	低压液化石油气 (LPG/NG)
净重	Net Weight	105kg	76kg	51kg



扒炉 Gas Griddle



台式燃气平扒炉
Gas Griddle(Flat plate)

型号	Model	BGH-48
规格	Size	1200X660X480mm
热功率	Hp	18kW
气源	Gas Source	低压液化石油气 (LPG/NG)
净重	Net Weight	105kg



台式燃气平扒炉
Gas Griddle(Flat plate)

型号	Model	BGH-36
规格	Size	900X660X480mm
热功率	Hp	13.5kW
气源	Gas Source	低压液化石油气 (LPG/NG)
净重	Net Weight	76kg



台式燃气平扒炉
Gas Griddle(Flat plate)

型号	Model	BGH-24
规格	Size	600X660X480mm
热功率	Hp	9kW
气源	Gas Source	低压液化石油气 (LPG/NG)
净重	Net Weight	51kg



燃气半平半坑扒炉
Gas Griddle(2/3 Flat & 1/3 Grooved)

型号	Model	BGH-722
规格	Size	730X550X400mm
热功率	Hp	9.4kW
气源	Gas Source	低压液化石油气 (LPG)
净重	Net Weight	28kg

燃气平扒炉
Gas Griddle(Flat plate)

型号	Model	BGH-720
规格	Size	730X550X400mm
热功率	Hp	9.4kW
气源	Gas Source	低压液化石油气 (LPG)
净重	Net Weight	31kg



BGH-730



BGH-718



BGH-740

燃气平扒炉
Gas Griddle(Flat plate)

型号	Model	BGH-718
规格	Size	550X500X400mm
热功率	Hp	9.4kW
气源	Gas Source	低压液化石油气 (LPG)
净重	Net Weight	19.4kg

燃气平扒炉连炸炉
Gas Griddle Even Fryer(Flat Plate)

型号	Model	BGH-730	BGH-740
规格	Size	730X560X470mm	1020X560X470mm
热功率	Hp	9.4kW	14.4kW
净重	Net Weight	20kg	50kg



烧烤炉系列
Rotisserie Chicken Rotisserie

烧烤炉系列

Chicken Rotisseries



立式旋转双头烤鸡炉

Two Full Lamp Chicken Rotisserie



型号	Model	BEB-206-2A
规格	Size	1400X665X1620mm
功率	Hp	7.5Kw+7.5Kw
电压	Volt	220V
净重	Net Weight	84kg

特性: 电热管加热器, 自动旋转功能



立式燃气旋转双头烤全羊炉

型号	Model	BGB-306-2A
规格	Size	1400X665X1620mm
热功率	Hp	9kW
气源	Gas Source	低压液化石油气(LPG/LNG)
净重	Net Weight	84kg

特性: 燃气红外线加热器, 自动旋转功能



立式电旋转双头烤全羊炉
Electric Two Full Lamp Rotisserie



型号	Model	BEB-206-2
规格	Size	1400X665X1620mm
功率	Hp	7.5Kw+7.5Kw
电压	Volt	220V
净重	Net Weight	80kg

特性: 电热管加热器, 自动旋转功能



立式燃气旋转双头烤全羊炉
Gas Two Full Lamp Rotisserie

型号	Model	BGB-306-2
规格	Size	1400X665X1620mm
热功率	Hp	9kW
气源	Gas Source	低压液化石油气(LPG/LNG)
净重	Net Weight	80kg

特性: 燃气红外线加热器, 自动旋转功能



立式燃气旋转烤鸡炉
Gas Chicken Rotisseries

型号	Model	BGB-306
规格	Size	670X550X1580mm
热功率	Hp	7.5kW
气源	Gas Source	低压液化石油气(LPG/NG)
净重	Net Weight	77kg

特性：燃气红外线加热器，自动旋转功能

烧鸡炉系列



立式电旋转烤鸡炉
Electric Chicken Rotisserie

型号	Model	BEB-206
规格	Size	670X550X1580mm
功率	Hp	7.5kW
电压	Volt	220V
净重	Net Weight	84kg

特性：电热管加热器，自动旋转功能



旋转燃气烤鸡炉
Chicken Rotisserie

型号	Model	BGB-366	BGB-368
规格	Size	810X630X610mm	1010X630X800mm
热功率	Hp		
气源	Gas Source	低压液化石油气 (LPG/NG)	
净重	Net Weight	63kg	75kg

特性：燃气红外线加热器，自动旋转功能

单层旋转电烤鸡炉
Electric Chicken Rotisserie

型号	Model	BEB-266	BEB-268
规格	Size	810X630X610mm	1010X630X800mm
功率	Hp	4.5KW	6KW
电压	Volt	220V	220V
净重	Net Weight	65Kg	71Kg

特性：电热管加热器，自动旋转功能



单层旋转电烤鸡炉
Electric Chicken Rotisserie

型号	Model	BEB-201
规格	Size	1000X900X1060mm
功率	Hp	3N~380V
电压	Volt	9.3kW
净重	Net Weight	133.5kg

特性：电热管加热器，自动旋转功能

双层旋转电烤鸡炉
Double Layers Electric Rotisserie

型号	Model	BEB-202
规格	Size	1000X900X2020mm
功率	Hp	3N~380V
电压	Volt	18.6kW
净重	Net Weight	270kg

特性：电热管加热器，自动旋转功能

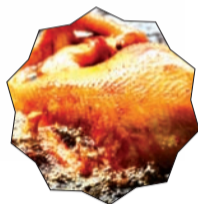

烤鸡炉 Chicken Rotisseries

烤鸡炉
Chicken Rotisserie

型号	Model	BGT-3P
规格	Size	450X330X560mm
热功率	Hp	10kW/0.2kW 电压220V
气源	Gas Source	低压液化石油气(LPG)
净重	Net Weight	60kg
特性: 燃气红外线加热器, 自动旋转功能		



烤鸡炉
Chicken Rotisserie

型号	Model	BGT-6P
规格	Size	1185X490X1350mm
热功率	Hp	20KW/0.3KW 电压220V
气源	Gas Source	低压液化石油气(LPG)
净重	Net Weight	85kg

特性: 燃气红外线加热器, 自动旋转功能



烤鸡炉
Chicken Rotisserie

型号	Model	BGT-9P
规格	Size	1185X490X1880mm
热功率	Hp	30kW/0.4kW 电压220V
气源	Gas Source	低压液化石油气(LPG)
净重	Net Weight	115kg

特性: 燃气红外线加热器, 自动旋转功能



中东烧烤炉 Chicken Rotisseries



燃气中东烧烤炉
Mini Gas kebab Machine

型号	Model	BGB-25A
规格	Size	400X290X500mm
热功率	Hp	7.7kW
气源	Gas Source	低压液化石油气 (LPG)
净重	Net Weight	9.5kg

特性: 燃气红外线加热器, 自动旋转功能



电热中东烧烤炉
Electric Doner Kebab Machine

型号	Model	BEB-850	BEB-808
规格	Size	520X640X950mm	520X640X1040mm
功率	Hp	6kW	9kW
电压	Volt	220V/3N~380V	220V/3N~380V
净重	Net Weight	25.7kg	30kg

特性: 电热管加热器, 自动旋转功能





BGB-800A (二头)



BGB-800 (三头)



BGB-950 (四头)

燃气中东烧烤炉
Gas kebab Machine

型号	Model	BGB-800A (二头)	BGB-800 (三头)
规格	Size	520X640X780mm	520X640X950mm
热功率	Hp	7.5kW	11.5kW
气源	Gas Source	低压液化石油气(LPG)	低压液化石油气(LPG)
净重	Net Weight	25 kg	28 kg

特性：燃气红外线加热器，自动旋转功能

燃气中东烧烤炉
Gas kebab Machine

型号	Model	BGB-950 (四头)
规格	Size	520X640X1040mm
热功率	Hp	15.4kW
气源	Gas Source	低压液化石油气(LPG)
净重	Net Weight	30kg

特性：燃气红外线加热器，自动旋转功能



燃气中东烧烤炉
Gas kebab Machine

型号	Model	BGB-1050 (五头)
规格	Size	520X640X1200mm
热功率	Hp	19.8kW
气源	Gas Source	低压液化石油气(LPG)
净重	Net Weight	32kg

特性：燃气红外线加热器，自动旋转功能



燃气中东烧烤炉
Gas kebab Machine

型号	Model	BGB-1150 (六头)
规格	Size	520X640X1380mm
热功率	Hp	24kW
气源	Gas Source	低压液化石油气(LPG)
净重	Net Weight	36kg

特性：燃气红外线加热器，自动旋转功能



升降面火炉
Electric Lift Salamander

型号	Model	BEB-450
规格	Size	450X450X470mm
功率	Hp	2.8kW
电压	Volt	220V
净重	Net Weight	34kg



升降面火炉
Electric Lift Salamander

型号	Model	BEB-600	BEB-800
规格	Size	600X450X470mm	800X450X470mm
功率	Hp	4kW	6kW
电压	Volt	220V	220V
净重	Net Weight	49kg	55kg



BAT-937



BAT-938



挂式电面火炉
Electric Hanging Salamander

型号	Model	BAT-936	BAT-937
规格	Size	610X310X280mm	800X450X470mm
功率	Hp	2kW	4kW
电压	Volt	220V	220V
净重	Net Weight	9kg	28kg

挂式电面火炉
Electric Hanging Salamander

型号	Model	BAT-938
规格	Size	575X390X390mm
功率	Hp	2.2kW
电压	Volt	220V
净重	Net Weight	15.8kg



BAT-936



电热面火炉
Electric Infrared Salamander

型号	Model	BET-14
规格	Size	680X440X610mm
功率	Hp	4.2kW
电压	Volt	220V
净重	Net Weight	31kg

电热面火炉
Electric Infrared Salamander

型号	Model	BET-16
规格	Size	880X440X610mm
热功率	Hp	6.3kW
气源	Gas Source	220V
净重	Net Weight	48kg

烧烤系列



BGT-20 BGT-18

BGT-16



红外线燃气面火炉
Gas Infrared Salamander

型号	Model	BGT-20	BGT-18
规格	Size	1280X440X610mm	1080X440X610mm
热功率	Hp	20.5kW	18.5kW
气源	Gas Source	低压液化石油气 (LPG)	
净重	Net Weight	60kg	52kg



BGT-14

红外线燃气面火炉
Gas Infrared Salamander

型号	Model	BGT-16	BGT-14
规格	Size	880X440X610mm	680X440X610mm
热功率	Hp	16kW	10kW
气源	Gas Source	低压液化石油气 (LPG)	
净重	Net Weight	48kg	31.6kg



无烟烧烤炉 Smokeless Barbecue Oven



电热无烟烧烤炉

Electric Smokeless Barbecue Oven

型号	Model	BEB-580
规格	Size	650X385X240mm
烧烤区	Roast Area	470X180mm
功率	Hp	3kW
电压	Volt	220V
净重	Net Weight	6.18kg



电热无烟烧烤炉

Electric Smokeless Barbecue Oven

型号	Model	BEB-220	BEB-220B
规格	Size	1200X380X220mm	1200X420X220mm
烧烤区	Roast Area	900X260mm	900X300mm
功率	Hp	7kW	7kW
电压	Volt	220V	220V
净重	Net Weight	18kg	18kg



电热无烟烧烤炉

Electric Smokeless Barbecue Oven

型号	Model	BEB-110
规格	Size	1200X310X220mm
烧烤区	Roast Area	880X180mm
功率	Hp	6kW
电压	Volt	220V
净重	Net Weight	10.6kg

电热无烟烧烤炉

Electric Smokeless Barbecue Oven

型号	Model	BEB-150
规格	Size	1500X385X220mm
烧烤区	Roast Area	1180X180mm
功率	Hp	9kW
电压	Volt	220V
净重	Net Weight	13.6kg

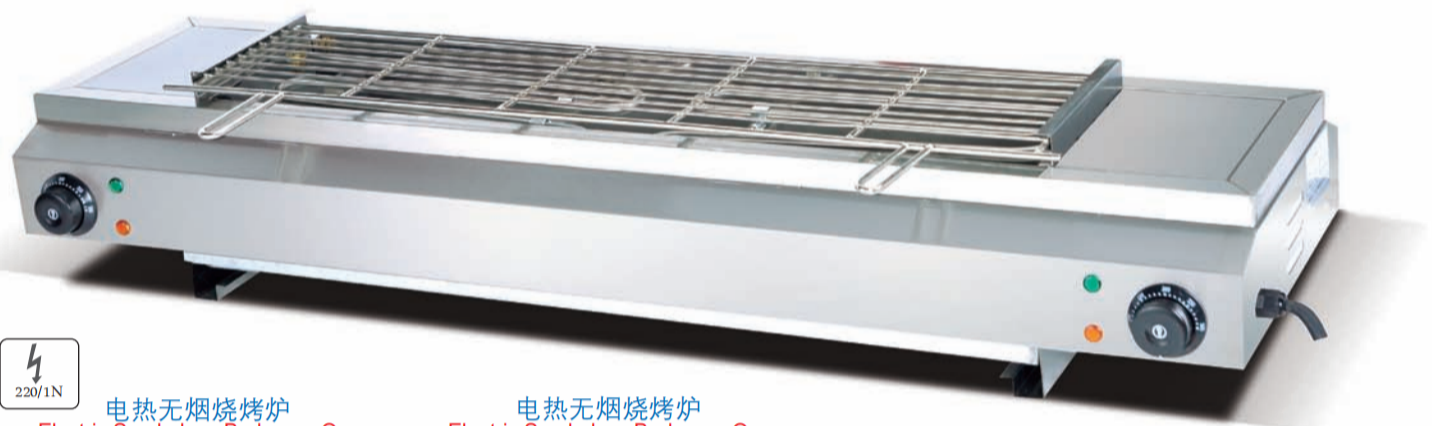



燃气无烟烧烤炉
Gas Smokeless Barbecue Oven

型号	Model	BGB-580
规格	Size	700X420X235mm
烧烤区	Roast Area	470X180mm
热功率	Hp	3.4kW
气源	Gas Source	低压液化石油气(LPG)
净重	Net Weight	7kg



燃气无烟烧烤炉
Gas Smokeless Barbecue Oven

型号	Model	BGB-220
规格	Size	1200X480X235mm
烧烤区	Roast Area	880X260mm
热功率	Hp	7.2kW
气源	Gas Source	低压液化石油气(LPG)
净重	Net Weight	12.7kg

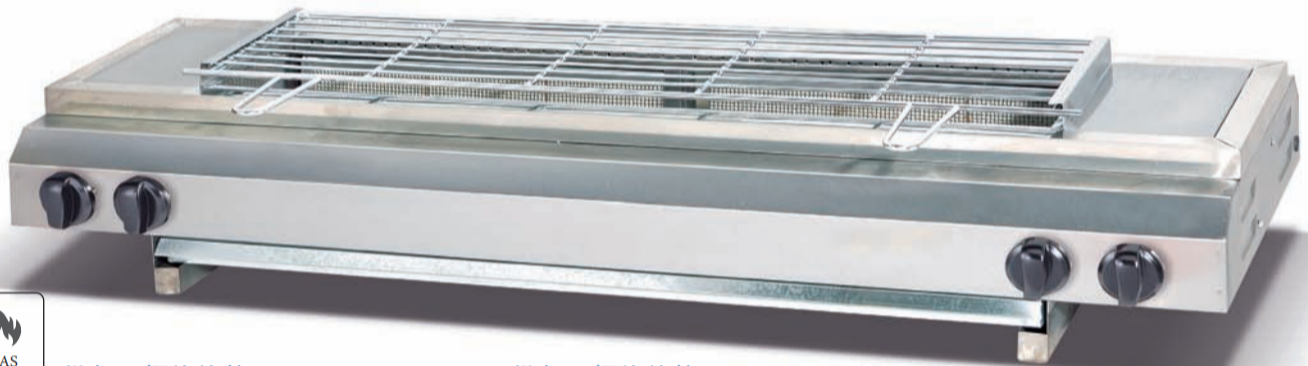

燃气无烟烧烤炉
Gas Smokeless Barbecue Oven

型号	Model	BGB-110
规格	Size	1200X420X235mm
烧烤区	Roast Area	880X180mm
热功率	Hp	6.8kW
气源	Gas Source	低压液化石油气(LPG)
净重	Net Weight	11.7kg

燃气无烟烧烤炉
Gas Smokeless Barbecue Oven

型号	Model	BGB-150
规格	Size	1500X420X235mm
烧烤区	Roast Area	1180X180mm
热功率	Hp	8.8kW
气源	Gas Source	低压液化石油气(LPG)
净重	Net Weight	14.7kg



电热无烟烧烤炉
Electric Smokeless Barbecue Oven

型号	Model	BEB-700
规格	Size	700X400X210mm
烧烤区	Roast Area	665X265mm
功率	Hp	4.8kW
电压	Volt	220V



电热无烟烧烤炉
Electric Smokeless Barbecue Oven

型号	Model	BEB-110B
规格	Size	1030X400X210mm
烧烤区	Roast Area	965X265mm
功率	Hp	8.4kW
电压	Volt	220V



烧烤炉系列
Electric Smokeless Barbecue Oven Series



电热无烟烧烤炉
Electric Smokeless Barbecue Oven

型号	Model	BEB-800
规格	Size	800X600X180mm
烧烤区	Roast Area	730X430mm
功率	Hp	8kW
电压	Volt	220V





喷流式煮面机

Convection pasta Cooker

煮面机系列
Convection Pasta Cooker



电热升降煮面炉
Electric Lift Pasta Cooker

型号	Model	BEH-350D
规格	Size	350X800X950mm
功率	Hp	4.5kW
电压	Volts	3N~380V
净重	Net Weight	36kg



电热升降煮面炉
Electric Lift Pasta Cooker

型号	Model	BEH-550D
规格	Size	550X800X950mm
功率	Hp	9kW
电压	Volts	3N~380V
净重	Net Weight	78kg



喷流式电热煮面机带汤盆
Electric Convection pasta Cooker&Bain Marie

喷流式煮面机带汤盆(燃气)
Gas Convection pasta Cooker&Bain Marie

型号	Model	BEH-1276
规格	Size	1200X700X870mm
功率	Hp	10kW
电压	Volts	380V
净重	Net Weight	69kg

型号	Model	BGH-1276
规格	Size	1200X700X870mm
热功率	Hp	15.5kW
气源	Gas Source	低压液化石油气(LPG)
净重	Net Weight	69kg

特征: 6头煮面炉带汤盆/调料盆



喷流式电热煮面机带汤盆
Electric Convection pasta Cooker&Bain Marie

喷流式煮面机带汤盆(燃气)
Gas Convection pasta Cooker&Bain Marie

型号	Model	BEH-1076
规格	Size	1025X700X870mm
功率	Hp	8kW
电压	Volts	220V
净重	Net Weight	42kg

型号	Model	BGH-1076
规格	Size	1025X700X870mm
热功率	Hp	14.6kW
气源	Gas Source	低压液化石油气(LPG)
净重	Net Weight	42kg

特征: 6头煮面炉带汤盆/调料盆



喷流式电热煮面机带汤盆
Electric Convection pasta Cooker & Bain Marie

型号	Model	BEH-874A
规格	Size	855X700X870mm
功率	Hp	6kW
电压	Volts	220V
净重	Net Weight	35kg

喷流式煮面机带汤盆(燃气)
Gas Convection pasta Cooker & Bain Marie

型号	Model	BGH-774A
规格	Size	855X700X870mm
热功率	Hp	11kW
气源	Gas Source	低压液化石油气(LPG)
净重	Net Weight	35kg

煮面机系列
Convection pasta Cooker



喷流式电热煮面机(9孔)
Electric Convection pasta Cooker

型号	Model	BEH-879
规格	Size	600X700X870mm
功率	Hp	9kW
电压	Volts	380V-3N
净重	Net Weight	36kg

特征: 9头煮面炉带汤盆

燃气喷流式煮面机(9孔)
Gas Convection pasta Cooker

型号	Model	BGH-779
规格	Size	600X700X870mm
热功率	Hp	14.6kW
气源	Gas Source	低压液化石油气(LPG)
净重	Net Weight	36kg



立式喷流式电热煮面机 (6孔)
Electric Convection pasta Cooker

型号	Model	BEH-876
规格	Size	600X700X870mm
功率	Hp	6kW
电压	Volts	220V
净重	Net Weight	26 kg



立式喷流式燃气煮面机 (6孔)
Gas Convection pasta Cooker

型号	Model	BGH-776
规格	Size	600X700X870mm
热功率	Hp	8.4kW
气源	Gas Source	低压液化石油气 (LPG)
净重	Net Weight	26 kg



立式喷流式电热煮面机 (4孔)
Electric Convection pasta Cooker

型号	Model	BEH-874
规格	Size	430X700X870mm
功率	Hp	4kW
电压	Volts	220V
净重	Net Weight	21kg

立式喷流式燃气煮面机 (4孔)
Gas Convection pasta Cooker

型号	Model	BGH-774
规格	Size	430X700X870mm
热功率	Hp	5.6kW
气源	Gas Source	低压液化石油气 (LPG)
净重	Net Weight	21kg

台式煮面机

Counter Top Convection pasta Cooker



台式电热煮面机
Counter Top Electric Pasta Cooker



型号	Model	BEH-688A
规格	Size	600X540X340mm
功率	Hp	6kW
电压	Volts	220V
净重	Net Weight	20kg



立式喷流式燃气煮面机
Gas Convection pasta Cooker



型号	Model	BGH-676
规格	Size	600X630X410mm
热功率	Hp	9.5kW
气源	Gas Source	低压液化石油气 (LPG)
净重	Net Weight	21kg



台式电热煮面机
Counter Top Electric Pasta Cooker



型号	Model	BEH-488
规格	Size	430X540X340mm
功率	Hp	4kW
电压	Volts	220V
净重	Net Weight	14kg

电热汤池

Electric Bain-Marie



三盆电热汤池
Electric Bain-Marie(3-pans)

型号	Model	BEH-BM3
规格	Size	920X350X340mm
功率	Hp	1.5kW
电压	Volts	220V
净重	Net Weight	13.5kg



四盆电热汤池
Electric Bain-Marie(4-pans)

型号	Model	BEH-BM4
规格	Size	1185X350X340mm
功率	Hp	1.5kW
电压	Volts	220V
净重	Net Weight	17kg



五盆电热汤池
Electric Bain-Marie(5-pans)

型号	Model	BEH-BM5
规格	Size	1450X350X340mm
功率	Hp	1.8kW
电压	Volts	220V
净重	Net Weight	20kg



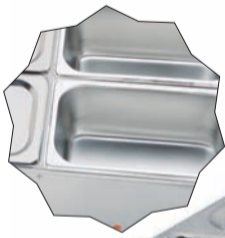

电热汤池
Electric Bain-marie(Six Pans)

型号	Model	BEH-6
规格	Size	690X580X260mm
功率	Hp	1.5kW
电压	Volts	220V
净重	Net Weight	11kg

盆数: 1/3×4"×6

电热汤池
Electric Bain-marie(Four Pans)

型号	Model	BEH-4
规格	Size	690X580X260mm
功率	Hp	1.5kW
电压	Volts	220V
净重	Net Weight	13kg

盆数: 1/2×6"×4

电热汤池
Electric
Bain-Marie



电热汤池
Electric Bain-marie(Three Pans)

型号	Model	BEH-3
规格	Size	580X360X260mm
功率	Hp	1.5kW
电压	Volts	220V
净重	Net Weight	8.5kg

盆数: 1/3×6"×3



电热汤池
Electric Bain-marie(Two Pans)

型号	Model	BEH-2
规格	Size	580X360X260mm
功率	Hp	1.5kW
电压	Volts	220V
净重	Net Weight	8kg

盆数: 1/2×6"×2



立式关东煮
Electric Donut Fryer

型号	Model	BEH-810	BEH-800
规格	Size	1100X750X1200mm	800X750X1200mm
功率	Hp	8.5kW	5.9kW
电压	Volts	220V	220V



电煮/关东煮
Electric Donut Fryer



台式关东煮
Electric Donut Fryer

型号	Model	BEH-800A
规格	Size	800X630X680mm
功率	Hp	5.9kW
电压	Volts	220V

关东煮
Donut Fryer





关东煮 Donut Fryer

关东煮 (加玻璃罩)
Donut Fryer

型号	Model	BEH-20 (双盆18格)
规格	Size	570X370X450mm
功率	Hp	1.3kW+1.3kW
电压	Volts	220V
净重	Net Weight	20kg



Electric Donut Fryer
电热汤池/关东煮



A



B



C



D

BEH-20A/B/C/D (双盆18格)



关东煮
Donut Fryer

型号	Model	BEH-20A/B/C/D (双盆18格)
规格	Size	570X370X280mm
功率	Hp	1.3kW+1.3kW
电压	Volts	220V
净重	Net Weight	14kg



关东煮 Donut Fryer

关东煮
Donut Fryer

型号	Model	BEH-24
规格	Size	660X420X330mm
功率	Hp	1.8kW+1.8kW
电压	Volts	220V
净重	Net Weight	25kg



BEH-12



BEH-10A(单盆9格)



关东煮
Donut Fryer

型号	Model	BEH-12	BEH-10A/B(单盆9格)
规格	Size	450X360X300mm	370X310X280mm
功率	Hp	1.3kW+1.3kW	1.3kW
电压	Volts	220V	220V
净重	Net Weight	20kg	8kg



BEH-10B(单盆9格)



BEH-22



BEH-23



BEH-13

巧克力炉
Chocolate Stove

型号	Model	BEH-22	BEH-23
规格	Size	470X220X170mm	630X220X170mm
功率	Hp	0.8kW	0.8kW
电压	Volts	220V	220V
净重	Net Weight	5kg	8kg

茶叶蛋炉
Donut Fryer

型号	Model	BEH-13
规格	Size	650X400X280mm
功率	Hp	1.3kW+1.3kW+1.3kW
电压	Volts	220-240V
净重	Net Weight	20kg



BEH-20(1盆20格)



BEH-18(双盆18格)



BEH-15(1盆9格)



关东煮
Donut Fryer

型号	Model	BEH-20A(1盆20格)
规格	Size	600X570X170mm
功率	Hp	3.5kW
电压	Volts	220V
净重	Net Weight	15kg

关东煮
Donut Fryer

型号	Model	BEH-18(双盆18格)
规格	Size	670X370X330mm
功率	Hp	2.5kW+2.5kW
电压	Volts	220-240V
净重	Net Weight	12kg

关东煮
Donut Fryer

型号	Model	BEH-15(1盆9格)
规格	Size	310X470X330mm
功率	Hp	2.5kW
电压	Volts	220-240V
净重	Net Weight	6kg

保温柜 Display Showcase





双门保温餐车
Mobile Electric Food Warmer Cabinet

型号	Model	BDH-11-22
规格	Size	1540X975X1795mm
内规格	Bore Size	540X680X1380mm
容量	Capacity	22层
每层高	Per Tray Height	115mm
功率	Hp	2.62kW
电压	Volt	220V~240V
净重	Net Weight	230kg



BDH-11-21

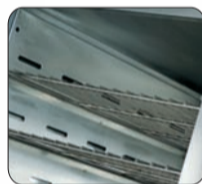

BDH-11-4

单门保温餐车
Mobile Electric Food Warmer Cabinet

四层保温餐车
Mobile Electric Food Warmer Cabinet

型号	Model	BDH-11-21	BDH-11-4
规格	Size	790X975X1795mm	850X600X1150mm
内规格	Bore Size	540X680X1380mm	720X420X840mm
容量	Capacity	11层	4层
每层高	Per Tray Height	115mm	200mm
功率	Hp	2.62kW	1.8kW
电压	Volt	220V~240V	220V~240V
净重	Net Weight	138kg	80kg



中餐保温柜
Chinese food warmer

型号	Model	BDH-10P
规格	Size	1500X700X860mm
功率	Hp	1.8kW
电压	Volt	220V
净重	Net Weight	43kg



弧型保温柜
Electric Curved Glass Warming Showcase

型号	Model	BDH-3P
规格	Size	950X466X610mm
功率	Hp	1.2kW
电压	Volt	220V
净重	Net Weight	30kg



弧型保温柜
Electric Curved Glass Warming Showcase

型号	Model	BDH-2P
规格	Size	660X466X610mm
功率	Hp	0.8kW
电压	Volt	220V
净重	Net Weight	21kg

弧型保温柜
Electric Curved Glass Warming Showcase

型号	Model	BDH-2P-1
规格	Size	330X460X610mm
功率	Hp	0.5kW
电压	Volt	220V
净重	Net Weight	10kg



弧型保温柜
Electric Curved Glass Warming Showcase

型号	Model	BR60-3
规格	Size	1220X480X620mm
功率	Hp	1.84kW
电压	Volt	220V
净重	Net Weight	56kg



弧型保温柜
Electric Curved Glass Warming Showcase

型号	Model	BR60A
规格	Size	690X480X715mm
功率	Hp	0.5kW
电压	Volt	220V
净重	Net Weight	56kg



弧型保温柜
Electric Curved Glass Warming Showcase

型号	Model	BR60-2
规格	Size	920X480X595mm
功率	Hp	1.84kW
电压	Volt	220V
净重	Net Weight	50kg

弧型保温柜
Electric Curved Glass Warming Showcase

型号	Model	BR60-1
规格	Size	660X480X640mm
功率	Hp	1.5kW
电压	Volt	220V
净重	Net Weight	37kg



保温柜
Hot Display Warmer

型号	Model	BDH-1P-T
规格	Size	350X420X730mm
功率	Hp	0.8kW
电压	Volt	220V
净重	Net Weight	16kg

保温柜
Hot Display Warmer

型号	Model	BDH-1P
规格	Size	350X425X500mm
功率	Hp	0.85kW
电压	Volt	220V
净重	Net Weight	16kg



陈列保温柜
Display Showcase

型号	Model	BDH-580
规格	Size	640X360X530mm
功率	Hp	1kW
电压	Volt	220V
净重	Net Weight	21.3kg

陈列保温柜
Display Showcase

型号	Model	BDH-701	BDH-702
规格	Size	650X500X580mm	900X500X580mm
功率	Hp	1.5kW	1.5kW
电压	Volt	220V	220V
净重	Net Weight	22kg	27kg

比萨烤炉

Pizza Oven



保温柜/烤箱系列
Insulation Cabinet/Oven Series



履带式电比萨烤炉
Electric Pizza Oven(single Layer)

型号	Model	BLD-1S	BLD-2S	BLD-3S
规格	Size	1100X620X370mm	1560X750X370mm	2500X1070X460mm
工作区域	work area	1000X380mm	1450X530mm	1800X880mm
功率	Hp	220~240V	380V~3N	380V~3N
电压	Volt	6.7kW	10.3kW	25.5kW
净重	Net Weight	45kg	65kg	85kg





热风循环电烤炉
Perspective Convection Oven



型号	Model	BEB-8A(带喷雾)
规格	Size	835X770X575mm
功率	Hp	5.8kW
电压	Volt	220V
净重	Net Weight	55kg



热风循环电烤炉
Perspective Convection Oven



型号	Model	BEB-4A(带喷雾)
规格	Size	595X530X570mm
功率	Hp	2.6kW
电压	Volt	220V
净重	Net Weight	39kg



热风循环电烤炉
Perspective Convection Oven



型号	Model	BEB-1A
规格	Size	595X530X570mm
功率	Hp	2.6kW
电压	Volt	220V
净重	Net Weight	39kg



电烤箱
Electric Oven



型号	Model	BEB-70RC
规格	Size	680X430X430mm
功率	Hp	2.4kW
电压	Volt	220V
净重	Net Weight	3kg



BEB-2 BGB-2

双层电比萨烤炉
Electric Pizza Oven(Double Layer)



型号	Model	BEB-2
规格	Size	910X790X760mm
功率	Hp	9.6kW
电压	Volt	3N-380V
净重	Net Weight	120kg

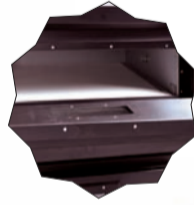

BEB-1 BGB-1

单层电比萨烤炉
Electric Pizza Oven(single Layer)



型号	Model	BEB-1
规格	Size	910X790X430mm
功率	Hp	4.8kW
电压	Volt	3N-380V
净重	Net Weight	60kg



双层燃气比萨烤炉
Gas Pizza Oven(Double Layer)



型号	Model	BGB-2
规格	Size	910X880X760mm
功率	Hp	9.2kW
气源	Gas Source	低压液化石油气(LPG)
净重	Net Weight	125kg

单层燃气比萨烤炉
Gas Pizza Oven(single Layer)



型号	Model	BGB-1
规格	Size	910X880X430mm
功率	Hp	4.2kW
气源	Gas Source	低压液化石油气(LPG)
净重	Net Weight	75kg



6片多士炉
6-Slice Electric Toaster

型号	Model	B6ATS
规格	Size	430X210X220mm
功率	Hp	3kW
电压	Volt	220V
净重	Net Weight	5kg



4片多士炉
4-Slice Electric Toaster

型号	Model	B4ATS
规格	Size	370X210X225mm
功率	Hp	2kW
电压	Volt	220V
净重	Net Weight	3kg



电热保温暖碟车(单头)
Electric plate warmer cart(1-Holder)

型号	Model	BER-1
规格	Size	450X485X770mm
功率	Hp	0.4kW
电压	Volt	220~240V
净重	Net Weight	31kg



电热保温暖碟车(双头)
Electric plate warmer cart(2-Holder)

型号	Model	BER-2
规格	Size	450X910X770mm
功率	Hp	0.8kW
电压	Volt	220~240V
净重	Net Weight	48kg



BEB-450

链式多士炉
Electric Conveyor Toaster

型号	Model	BEB-450
规格	Size	468X418X387mm
功率	Hp	2.64kW
电压	Volt	220V
净重	Net Weight	20kg



BEB-300

链式多士炉
Electric Conveyor Toaster

型号	Model	BEB-300
规格	Size	368X418X387mm
功率	Hp	1.94kW
电压	Volt	220V
净重	Net Weight	16kg

链式多士炉
Electric Conveyor Toaster

型号	Model	BEB-150
规格	Size	288X418X387mm
功率	Hp	1.5kW
电压	Volt	220V
净重	Net Weight	30kg



BEB-150

爆谷机 Popcorn Machine





屋顶爆谷机连车
Popcorn Machine

型号	Model	BEB-802-A
规格	Size	560X420X760mm
功率	Hp	1.3kW
电压	Volts	220V
净重	Net Weight	46kg

车身高度: 950X480X860mm



平顶爆谷机连车
Popcorn Machine

型号	Model	BEB-801-B
规格	Size	500X360X670mm
功率	Hp	1.3kW
电压	Volts	220V
净重	Net Weight	26kg

车身高度: 950X480X860mm



屋顶爆谷机
Popcorn Machine

型号	Model	BEB-802B
规格	Size	920X410X740mm
功率	Hp	2.2kW
电压	Volts	220V
净重	Net Weight	25kg





屋顶爆谷机
Popcorn Machine

型号	Model	BEB-802
规格	Size	560X420X760mm
功率	Hp	1.3kW
电压	Volts	220V
净重	Net Weight	22kg

不锈钢屋顶爆谷机
Popcorn Machine

型号	Model	BEB-803
规格	Size	580X420X740mm
功率	Hp	1.3kW
电压	Volts	220V
净重	Net Weight	15kg

平爆谷机
Popcorn Machine

型号	Model	BEB-801
规格	Size	500X360X670mm
功率	Hp	1.3kW
电压	Volts	220V
净重	Net Weight	14.5kg



棉花糖机

Candy Floss Machine

30秒一个

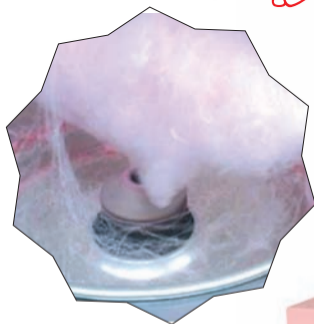

电棉花糖机
Electric Candy Floss Machine

型号	Model	BMH-500
规格	Size	520X570X530mm
功率	Hp	1030W
电压	Volts	220V
净重	Net Weight	12.8kg

电棉花糖机连车连罩
Electric Candy Floss Machine

型号	Model	BMH-505
规格	Size	520X750X945mm
功率	Hp	1030W
电压	Volts	220V
净重	Net Weight	12.8kg



燃气棉花糖机
Gas Candy Floss Machine

型号	Model	BGH-500
规格	Size	520X520X530mm
功率	Hp	900W
电压	Volts	220V
净重	Net Weight	12.8kg



炒板栗机
Electric Chestnut Roaster

型号	Model	BEB-460-2
规格	Size	950X680X1330mm
功率	Hp	6kW
电压	Volts	220V
净重	Net Weight	75kg

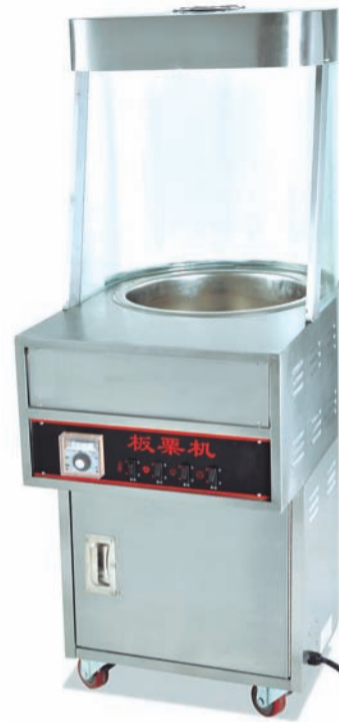

炒板栗机
Electric Chestnut Roaster

型号	Model	BEB-460
规格	Size	490X680X1330mm
功率	Hp	3kW
电压	Volts	220V
净重	Net Weight	41kg



爆谷机系列
Popcorn Machine

压板扒炉

Double Plate Panini Grill

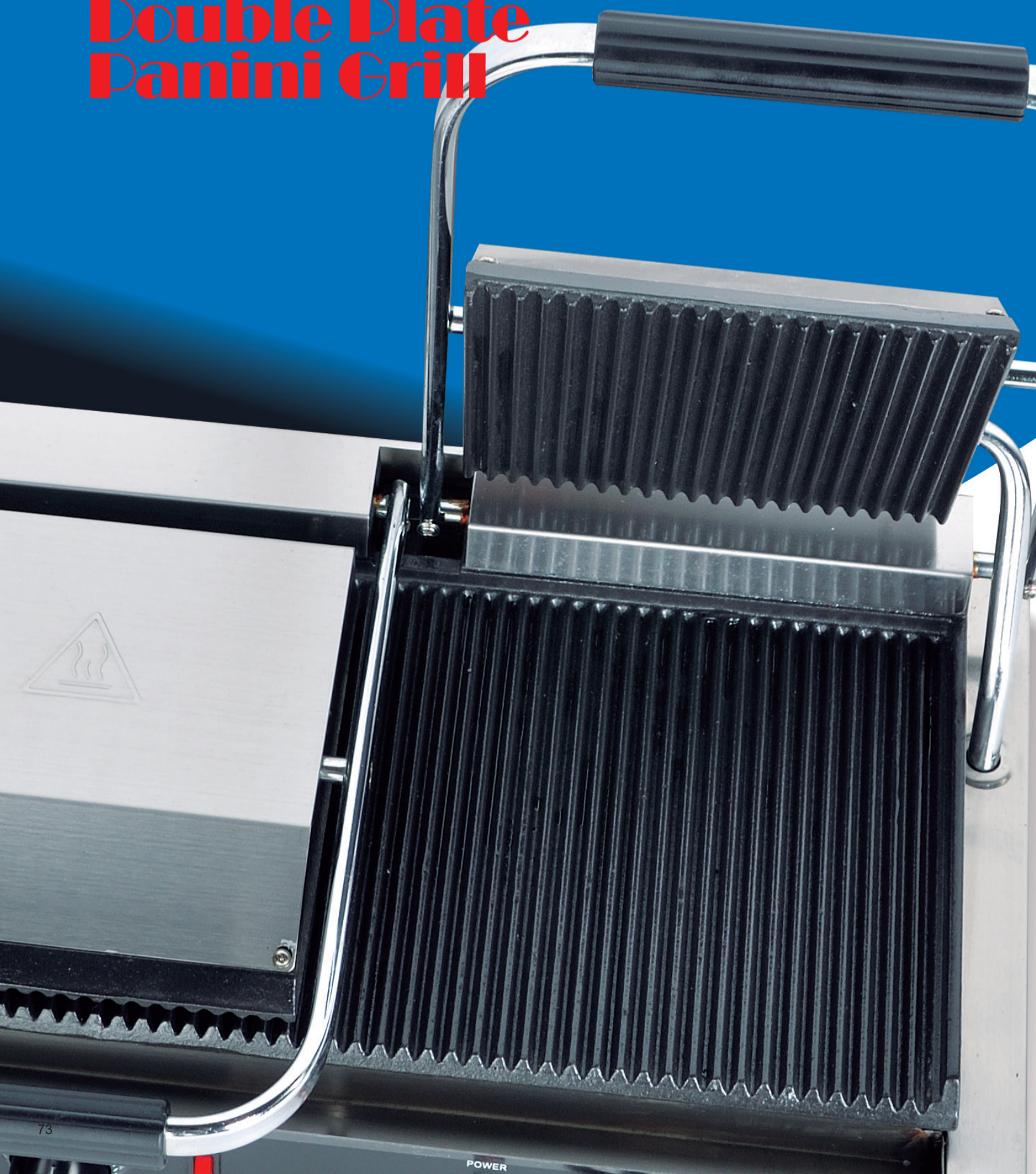



单头压板扒炉
Single Plate Panini Grill

型号	Model	BEG-811E	BEG-811
规格	Size	425X350X210mm	310X350X210mm
功率	Hp	2.2kW	1.8kW
电压	Volt	220V	220V
净重	Net Weight	17kg	15kg

双头压板扒炉
Double Plate Panini Grill

型号	Model	BEG-813
规格	Size	570X350X210mm
功率	Hp	3.6kW
电压	Volt	220V
净重	Net Weight	27kg



单头压板扒炉
Single Plate Panini Grill

型号	Model	BEG-811B
规格	Size	310X350X210mm
功率	Hp	1.8kW
电压	Volt	220V
净重	Net Weight	15kg

单头压板扒炉
Single Plate Panini Grill

型号	Model	BEG-811BE
规格	Size	425X350X210mm
功率	Hp	2.2kW
电压	Volt	220V
净重	Net Weight	19kg

小吃设备

SNACK EQUIPMENT

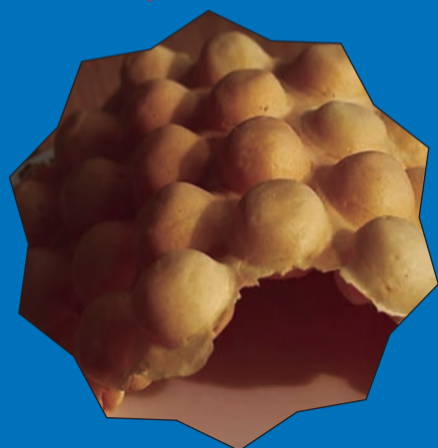



BEG-30

BEG-153

电蛋仔机
Electric Egg Cake Baker

型号	Model	BEG-30
规格	Size	230X230X250mm
功率	Hp	1.3kW
电压	Volts	220V
净重	Net Weight	6.5kg

心形华夫炉
Waffle Baker

型号	Model	BEG-153
规格	Size	360X252X230mm
功率	Hp	1kW
电压	Volts	220V
净重	Net Weight	6kg



单头烘雪糕皮机
Cone Baker

型号	Model	BZU-1
规格	Size	250X380X300mm
功率	Hp	1kW
电压	Volts	220V
净重	Net Weight	6.46kg



双头烘雪糕皮机
Cone Baker

型号	Model	BZU-2
规格	Size	500X380X300mm
功率	Hp	2kW
电压	Volts	220V
净重	Net Weight	11.65kg



UWB-1A



UWB-1A-B

220/1N

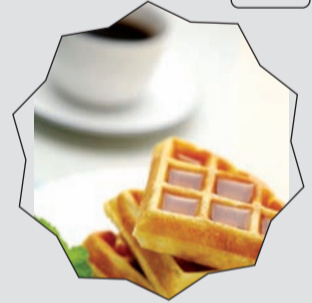

旋转华夫炉
Rotary Waffle Baker

型号	Model	BWB-1A
规格	Size	220X500X270mm
功率	Hp	1.4kW
电压	Volts	220V
净重	Net Weight	11.7kg

特性：可旋转使用

电子版旋转华夫炉
Rotary Waffle Baker

型号	Model	BWB-1A-B
规格	Size	220X500X270mm
功率	Hp	1.4kW
电压	Volts	220V
净重	Net Weight	11.7kg

特性：可旋转使用

220/1N



单头华夫炉
Single Head Waffle Baker

型号	Model	BWB-1
规格	Size	250X380X300mm
功率	Hp	1kW
电压	Volts	220V
净重	Net Weight	5.28kg

220/1N



双头华夫炉
Double Head Waffle Baker

型号	Model	BWB-2
规格	Size	500X380X300mm
功率	Hp	2kW
电压	Volts	220V
净重	Net Weight	10kg



BEG-6Q

韩式小鱼饼炉
Korean fish crisp maker

型号	Model	BEG-6Q
规格	Size	385X330X300mm
功率	Hp	1.5kW
电压	Volts	220V
净重	Net Weight	8kg



BEG-60

甜甜圈机
Donut Machine

型号	Model	BEG-60
规格	Size	385X480X180mm
功率	Hp	1.2kW
电压	Volts	220V
净重	Net Weight	8kg

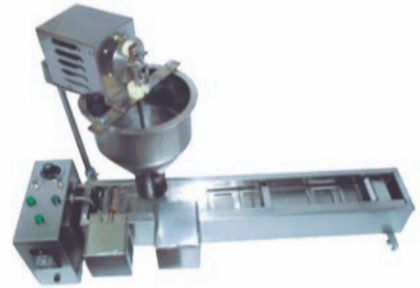

BEG-101

自动甜甜圈机
Automatic Donut Machine

型号	Model	BEG-101
规格	Size	1100X400X650mm
功率	Hp	3kW
电压	Volts	220V
净重	Net Weight	25kg
产量	Capacity:	150个/分钟, 150pcs/min

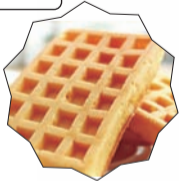

两片华夫炉
2 Pieces Waffle Baker

型号	Model	BEG-801
规格	Size	310X450X280mm
功率	Hp	2kW
电压	Volts	220V
净重	Net Weight	20kg

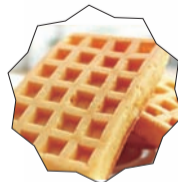

豪华四片华夫炉
4 Pieces Waffle Baker

型号	Model	BEG-133
规格	Size	450X350X300mm
功率	Hp	1.5kW
电压	Volts	220V
净重	Net Weight	10kg



五格玉米香酥机
Corn Crisp Maker(Five Parts)

型号	Model	BEG-5C
规格	Size	330X300X250mm
功率	Hp	1.5kW
电压	Volts	220V
净重	Net Weight	8kg

五格香酥机
Crisp machine(five parts)

型号	Model	BEG-5X
规格	Size	385X410X315mm
功率	Hp	1.5kW
电压	Volts	220V
净重	Net Weight	8kg

六格香酥机
Crisp machine(six parts)

型号	Model	BEG-6X
规格	Size	435X410X315mm
功率	Hp	1.5kW
电压	Volts	220V
净重	Net Weight	9kg



BEH-209
BEH-207
BEH-205



烤香肠机
Rolling Hot-god Grill

型号	Model	BEH-209(9rollers)	BEH-207(7rollers)	BEH-205(5rollers)
规格	Size	585X405X250mm	585X330X250/390mm	585X225X390mm
功率	Hp	1.8kW	1.4kW	1kW
电压	Volts	220V	220V	220V
净重	Net Weight	20kg	15kg	10kg

韩式蛋蛋肠机(节能款)
Korean Egg Sausage Machine

型号	Model	BSG-DCJ
规格	Size	345X155X235mm
功率	Hp	1.35kW
电压	Volts	220V
净重	Net Weight	4.7kg



电班戟炉
Electric Crepe Maker

型号	Model	BDE-1
规格	Size	450X485X240mm
功率	Hp	3kW
电压	Volts	220V
净重	Net Weight	19kg

电班戟炉
Electric Crepe Maker



型号	Model	BDE-2
规格	Size	860X485X240mm
功率	Hp	6kW
电压	Volts	220V
净重	Net Weight	36kg



燃气班戟炉
Gas Crepe Maker

型号	Model	BGE-2A
规格	Size	860X540X300mm
热功率	Hp	6kW
净重	Net Weight	50kg



燃气班戟炉
Gas Crepe Maker

型号	Model	BGE-1A
规格	Size	450X540X300mm
热功率	Hp	3kW
净重	Net Weight	19kg



电热鱼丸炉

Electric Takoyaki Machine

电热鱼丸炉
Electric Takoyaki Machine

型号	Model	BEH-768 (三板)
规格	Size	680X465X195mm
功率	Hp	6kW
电压	Volts	220V
净重	Net Weight	21kg



电热鱼丸炉

Electric Takoyaki Machine

型号	Model	BEH-767 (二板)
规格	Size	470X465X180mm
功率	Hp	4kW
电压	Volts	220V
净重	Net Weight	13kg



电热鱼丸炉

Electric Takoyaki Machine

型号	Model	BEH-766 (一板)
规格	Size	260X465X180mm
功率	Hp	2kW
电压	Volts	220V
净重	Net Weight	6kg



燃气鱼丸炉

Gas Takoyaki Machine

燃气鱼丸炉(三板)
Gas Takoyaki Machine(Three Plates)

型号	Model	BGH-768
规格	Size	680X500X220mm
热功率	Hp	
气源	Gas Source	低压液化石油气(LPG)
净重	Net Weight	24.5kg



燃气鱼丸炉(二板)
Gas Takoyaki Machine(Two Plates)

型号	Model	BGH-767
规格	Size	470X500X205mm
热功率	Hp	
气源	Gas Source	低压液化石油气(LPG)
净重	Net Weight	16.5kg



燃气鱼丸炉(二板)
Gas Takoyaki Machine(Two Plates)

型号	Model	BGH-766
规格	Size	260X500X205mm
热功率	Hp	
气源	Gas Source	低压液化石油气(LPG)
净重	Net Weight	8.5kg



弧形玻璃蒸包柜
Electric steamed buns cabinet

型号	Model	BEH-500C
规格	Size	400X430X770mm
功率	Hp	1.1kW
电压	Volts	220V
净重	Net Weight	26kg
温度范围	temperature	50~250°C



玻璃蒸包柜
Electric steamed buns cabinet

型号	Model	BEH-500L
规格	Size	380X400X750mm
功率	Hp	1.1kW
电压	Volts	220V
净重	Net Weight	26kg
温度范围	temperature	50~250°C



玻璃蒸包柜
Electric steamed buns cabinet

型号	Model	BEH-600L
规格	Size	460X520X830mm
功率	Hp	1.5kW
电压	Volts	220V
净重	Net Weight	33kg
温度范围	temperature	30~95°C



微电脑玻璃蒸包柜
Computer Control Heat

型号	Model	BEH-500S	BEH-600S
规格	Size	380X400X750mm	580X460X830mm
功率	Hp	1.1kW	1.5kW
电压	Volts	220V	220V
净重	Net Weight	26kg	41kg
温度范围	temperature	30~95°C	30~95°C

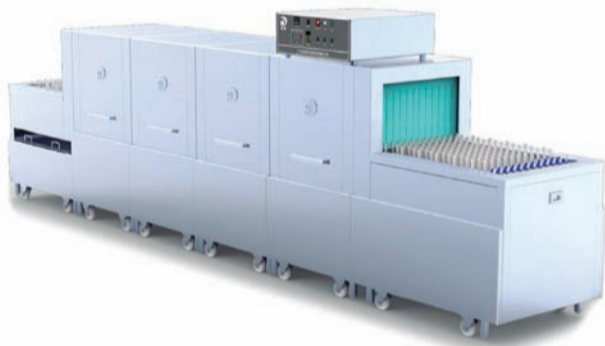
洗碗机
Dish-washing Machine技术参数/型号:D-320M(内宽840)
3道主洗2道漂洗

规格: 5400x1100x1650mm
洗涤量: 3500-4000个/小时
耗水量: 每小时650升
变频器: 进口丹佛斯
洗涤方式: 斜插式/平铺式
洗涤温度: 50-65℃
接驳要求: 三相五线制
电线电缆: 20平方铜芯线
电压/频率: 380V/50HZ

进水管径: 20mm
排水管径: 50mm
水泵功率: 2.2KW*1台
漂洗水泵功率: 0.37KW
最大洗涤高度: 350mm
传动电机: 0.37KW
高温漂洗温度: 80-90℃
高温漂洗功率: 24KW
用电总功率: 31.34KW
用燃气总功率: 7.34W

技术参数/型号:D-122M(内宽840)
1道主洗2道漂洗2道烘干

规格: 5400x1100x1650mm
洗涤量: 3500-4000个/小时
耗水量: 每小时500升
变频器: 进口丹佛斯
洗涤方式: 斜插式/平铺式
洗涤温度: 50-65℃
接驳要求: 三相五线制
电线电缆: 25平方铜芯线
电压/频率: 380V/50HZ
进水管径: 20mm
排水管径: 50mm

水泵功率: 2.2KW*1台
漂洗水泵功率: 0.37KW
高温风机功率: 2.2KW*2台
最大洗涤高度: 350mm
烘干加热功率: 18KW
传动电机: 0.37KW
高温漂洗温度: 80-90℃
高温漂洗功率: 24KW
用电总功率: 49.34KW
用燃气总功率: 25.34W

技术参数/型号:D-222M(内宽840)
2道主洗2道漂洗2道烘干

规格: 6200x1100x1850mm
洗涤量: 4000-4500个/小时
耗水量: 每小时560升
变频器: 进口丹佛斯
洗涤方式: 斜插式/平铺式
洗涤温度: 50-65℃
接驳要求: 三相五线制
电线电缆: 35平方铜芯线
电压/频率: 380V/50HZ
进水管径: 20mm
排水管径: 50mm

水泵功率: 2.2KW*2台
漂洗水泵功率: 0.37KW
高温风机功率: 2.2KW*2台
最大洗涤高度: 350mm
烘干加热功率: 18KW
传动电机: 0.37KW
高温漂洗温度: 80-90℃
高温漂洗功率: 24KW
用电总功率: 51.54KW
用燃气总功率: 27.54W

设备特点

由全304#不锈钢制造; 强力高压喷淋系统、紧急控制系统、传送系统等旗舰组成。

适应各种材质、形状的餐具, 应用广泛, 具备智能控制系统。水温调节系统恒温高压冲洗; 底噪节能, 降低人力及资源成本。

安全保护装置, 无人取碗时自动停机, 处于待机状态。

设备入口底部设有接渣筛网, 操作简单, 清洁方便。

多功能化全自动商用洗碗机故障自检, 问题一目了然, 维护方便快捷。

设备可以自动调节温度, 自动降温、升温系统, 防止坏仿陶瓷被破坏或变色。

恒温加热+进水预热, 充分利用水温循环进行预热进水, 更省电, 更节能。

适用范围: 陶瓷、不锈钢、密胺、塑料及各种异形餐具。

2. 与机器连接的电源、进水、排水管路、蒸汽管路和通风管路必须符合国家相关规定与标准,

注意:

1. 为了方便维修, 推荐用户安装独立的电源装置和手动阀, 分别用于断开机器的电源、水源和蒸汽。

型号D-J01
规格尺寸720X720X1915MM

机器入口宽度580mm
最大洗涤高度500mm
最大耗水量2.5mm升/框
最大洗涤量35框/小时
喷淋温度82-90℃
洗涤温度60-75℃
加热方式电加热
水池加热功率9KW
总功率30KW/380V
漏电开关额定电流32A
漂洗加热功率9KW
电源线要求10平方线
性能简述双泵喷淋

揭盖式洗碗机

1. 用于酒店、宾馆和餐厅等;
2. 主洗温度60-75℃, 漂洗温度82-90℃;

3. 液晶屏数字显示;

4. 三挡操作, 含电加热及自动排水和清洗功能

性能特点

1. 全304#不锈钢结构, 确保产品耐用可靠, 旋转式洗涤臂和喷淋臂, 高效高压热水喷淋, 洗涤效果更好。

2. 洗涤臂上的内凹防堵塞出水嘴, 冲洗力强, 喷水范围广。

独特的管状喷淋臂及特殊的喷嘴设计, 提高喷淋效果。

3. 微型计算机程序控制, 三档洗涤时间自由选择, 适应不同的洗涤要求。

4. 全感应式触摸面板, 防水、防霉、防污。自动注水, 自动清洗功能, 操作简便灵活。

5. 机器集成洗涤剂催干剂分配器, 不用另外购置分配器。

6. 倾斜式内顶盖, 防止残余的洗涤液滴落在干净的餐具上。



制冰机 ICE-MAKING MACHINE



型号 Model	外形尺寸 Size(mm)	冰形 Ice Model	冷媒 Refrigerant	电压 Volt	功率 Hp	日产冰量 Daily production	储冰箱容量 Bin capacity
ZB-20B	420X450X760	方块 Diamond	R22/R134A R22/R134A	220V/110V	220W	55/25Kg	33/15Kg
ZB-60B	580X560X890	方块 Diamond	R22/R134A R22/R134A	220V/110V	350W	88/40Kg	33/15Kg

型号 Model	外形尺寸 Size(mm)	冰形 Ice Model	冷媒 Refrigerant	电压 Volt	功率 Hp	日产冰量 Daily production	储冰箱容量 Bin capacity
ZB-80B	705X580X1000	方块 Diamond	R22/R134A	220V/50Hz	530W	132/60Kg	100/45Kg
ZB-90B	830X570X1010	方块 Diamond	R22/R134A	220V/50Hz	760W	176/80Kg	100/45Kg



分体式系列制冰机

SEPERATED SERIES ICE-MAKING MACHINE

冰粒尺寸 Ice Product Size:22X22X22mm

日产冰量测试条件: 环境温度20℃,水温15℃。

Testing methods for ice production volume per day:
ambient temperature 20℃, water temperature 15℃

冷凝方式: A/风冷/W水冷型

Condensation: A/Air-cooled W/Water-cooled



型号 Model	外形尺寸 Size(mm)	冰形 Ice Model	冷媒 Refrigerant	电压 Volt	功率 Hp	日产冰量 Daily production	储冰箱容量 Bin capacity
QB-300A	560X870X1400冰桶尺寸含脚	方块 Diamond	R22/R404A	220V/50Hz	760W	550/250Kg	440/220Kg
QB-400A	760X840X1600冰桶尺寸含脚	方块 Diamond	R22/R404A	220V/50Hz	800W/980W	770/350Kg	440/220Kg
QB-700A	760X840X1760冰桶尺寸含脚	方块 Diamond	R22/R404A	220V/50Hz	140W/1880W	1100/500Kg	440/220Kg



分体式系列制冰机

SEPERATED SERIES ICE-MAKING MACHINE

冰粒尺寸 Ice Product Size:22X22X22mm

日产冰量测试条件: 环境温度20℃,水温15℃。

Testing methods for ice production volume per day:
ambient temperature 20℃, water temperature 15℃

冷凝方式: A/风冷/W水冷型

Condensation: A/Air-cooled W/Water-cooled



型号 Model	外形尺寸 Size(mm)	冰形 Ice Model	冷媒 Refrigerant	电压 Volt	功率 Hp	日产冰量 Daily production	储冰箱容量 Bin capacity
QB-1000A	760X820X1780冰桶尺寸含脚	方块 Diamond	R22/R404A	220V/50Hz	1880W	550/250Kg	150Kg
QB-1500A	1200X820X1850冰桶尺寸含脚	方块 Diamond	R22/R404A	220V/50Hz	2300W	770/350Kg	300Kg
QB-1900A	1200X820X1850冰桶尺寸含脚	方块 Diamond	R22/R404A	220V/50Hz	2500W	1100/500Kg	300Kg



单头奶昔机
Milk Shaker

型号	Model	BJG-MS1
规格	Size	190X160X530mm
功率	Hp	0.15kW
电压	Volts	220V
净重	Net Weight	4.7kg



包装机
Packing Machine

型号	Model	BJG-MS2
规格	Size	230X230X530mm
功率	Hp	0.3kW
电压	Volts	220V
净重	Net Weight	8.2kg

型号	Model	BZM-2
规格	Size	670X430/550X140mm
功率	Hp	1.75/0.21kW
电压	Volts	220V
净重	Net Weight	6/7kg

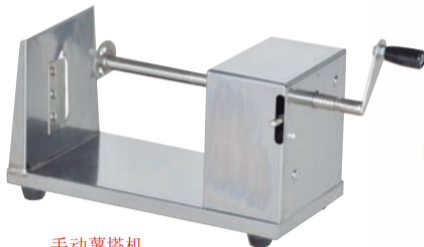

手动薯塔机



电动薯塔机



手动压橙汁机



汉堡加酱枪
Sauce Dispenser



八通道计时器
规格(Size): 300X112X60mm
功率HP: 20W/220V

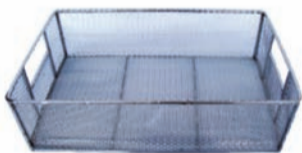

抖篮
规格(Size): 385X240X110mm



炸篮
规格(Size): 340X270X140mm



腿篮
规格(Size): 315X165X130mm



浸篮
规格(Size): Φ 220X150 (430)mm



炸篮
规格(Size): 340X165X150mm



分杯器 Cup Dispenser
FB-2 180X700X325mm
FB-3 180X700X480mm



分杯器



章鱼丸酱漏斗
Sauce Dispenser



薯条铲
Chips Scoop



汉堡酱桶
Hamburger Sauce Bucket