



(Encoders) ME-28 双通道磁性译码器 Two Channel Hall Effect Encoder



- ★使用相对湿度:20%~85% RH
Operating relative humidity
- ★使用温度范围:-40℃~+85℃
Operating temperature range

外形尺寸图/Appearance size

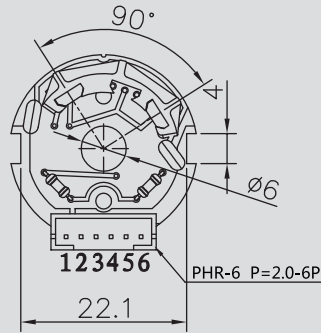
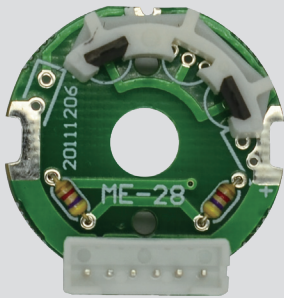

Two Channel Encoder
Connections:

- 1.MOTOR -
- 2.MOTOR +
- 3.HALL SENSOR Vcc
- 4.HALL SENSOR GND
- 5.HALL SENSOR A Vout
- 6.HALL SENSOR B Vout

*此译码器主要安装在RS-385,RS-395电机上。
*This decoder is mainly installed on RS-385, RS-395 motors.

*每周输出3PPR,7PPR
*Each turn output 3PPR,7PPR

规格特性 Charac teristics	代号 Symbol	测试条件 Test conditions	极小 Min	基本 Ref	最大 Max	单位 Units
输入电压 Supply Voltage	Vcc	-----	4.5	--	24	V
输入电流 Supply Current	Icc	-----	--	14	20	mA
输出电流 Output Current	Ic	Vce=12V; Gauss<-170	--	<0.1	20	mA
输出漏电流 Output Leakage Current	Icex	Output open; 25°C [77°F]	--	--	10	μ A
输出上升时间 Output Rise Time	Tr	RL=820Ω; CL=20pF; 25°C	--	0.5	1.5	μ S
输出下降时间 Output Fall Time	Tf	RL=820Ω; CL=20pF; 25°C	--	0.2	1.5	μ S

ELECTRICAL CHARACTERISTICS

At V=4.5V to 24V with 20mA load with Ta=-40°C to 125°C [-77°F to 257°F] unless otherwise noted.

输出电路\Output Circuit

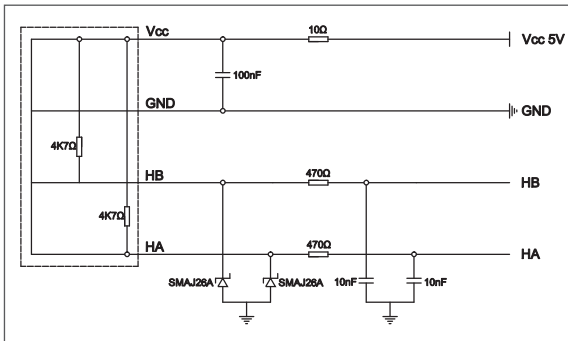

输出波形\Output Wave

