



江西安驰新能源科技有限公司
JIANGXI ANCHI NEW ENERGY TECHNOLOGY CO., LTD

编号: ACQI-DP-RD/028
版次: A0

产品规格书—IFP33173166-100Ah
Product Specification For IFP33173166-100Ah

Product Specification

产品规格书

型号: IFP33173166-100Ah

版本号: A0

编制 Prepared/Date	审核 Checked/Date	批准 Approved/Date	生效日期 Effective date
林伸			2024. 3. 1

客户名称:

客户确认: 对本规格书无异议

签字:

盖章:

客户确认日期:



受控副本



江西安驰新能源科技有限公司
JIANGXI ANCHI NEW ENERGY TECHNOLOGY CO., LTD

编号: ACQI-DP-RD/028
版次: A0

产品规格书—IFP33173166-100Ah
Product Specification For IFP33173166-100Ah

版本	修改内容	修改人	实施日期
A0	初版发行	林伸	2024-3-1





江西安驰新能源科技有限公司
JIANGXI ANCHI NEW ENERGY TECHNOLOGY CO., LTD

编号: ACQI-DP-RD/028
版次: A0

产品规格书—IFP33173166-100Ah
Product Specification For IFP33173166-100Ah

Contents 目录

1. Preface 前言
2. Definition 定义
3. Reference standard 参考标准
4. Cell type and size 电池型号及尺寸
5. Cell parameters and performance 电池参数和性能
6. Storage, quality guarantee period 存储, 保质期
7. Usage and test 电池使用及测试注意事项
8. Warning and cautions 电池使用时警告事项
9. Disclaimer 免责声明





江西安驰新能源科技有限公司
JIANGXI ANCHI NEW ENERGY TECHNOLOGY CO., LTD

编号: ACQI-DP-RD/028
版次: A0

产品规格书—IFP33173166-100Ah
Product Specification For IFP33173166-100Ah

1 Preface 前言

This specification describes the type and size, performance, technical characteristics, warning and caution of the prismatic cell. The specification only applies to IFP33173166-100Ah cell supplied by JIANGXI ANCHI NEW ENERGY TECHNOLOGY CO., LTD

本标准描述了方形电池的外型尺寸、特性、技术要求及注意事项。本标准只适用于江西安驰新能源科技有限公司生产的IFP33173166-100Ah单体电池。

2 Definition 定义

2.1 Rated capacity:

额定容量:

Rated capacity=100.0Ah: The capacity obtained when a cell is discharged at 1C to 2.5 volts at $25 \pm 2^\circ\text{C}$.

额定容量 Cap=100.0Ah, 指在 $25 \pm 2^\circ\text{C}$ 环境下, 以1C放电至终止电压为2.5V时的容量。

2.2 Standard charge method:

标准充电方式:

At $25 \pm 2.0^\circ\text{C}$, charge to 3.65V at a constant current of 1C, and then, charge continuously with constant voltage of 3.65V until the charge current drops below 0.05C.

在 $25 \pm 2.0^\circ\text{C}$ 环境下, 以1C恒流充电至单体电芯电压3.65V后, 转为恒压3.65V充电, 至充电电流小于0.05C时, 停止充电。

2.3 Standard discharge method:

标准放电方式:

At $25 \pm 2^\circ\text{C}$, discharge to 2.5V at a constant current of 1C.

在 $25 \pm 2^\circ\text{C}$ 环境下, 以1C恒流放电至电压2.5V。

2.4 Temperature 温度

The charge and discharge temperature specified in the specification refers to the surface center temperature of the cell, unless otherwise stated.

除特殊说明外, 规格书中所描述的充放电温度指的是电池表面中心的温度。

3 Reference standard 参考标准

GB/T 31467.3-2015 Lithium-ion power battery packs and systems for electric vehicles Part 3: Safety requirements and test methods

GB/T 31467.3-2015 电动汽车用锂离子动力蓄电池包和系统第3部分: 安全性要求与测试方法

GB/T 31484-2015 Cyclic Life Requirements and Test Method of Power Batteries for Electric Vehicles

GB/T 31484-2015 电动汽车用动力蓄电池循环寿命要求及试验方法

GB 38031-2020 Electric Vehicles Traction Battery Safety Requirements

GB 38031-2020 电动汽车用动力蓄电池安全要求

GB/T 31486-2015 Electrical Performance Requirements and Test Method of Power Batteries for Electric Vehicles

GB/T 31486-2015 电动汽车用动力蓄电池电性能要求及试验方法





江西安驰新能源科技有限公司
JIANGXI ANCHI NEW ENERGY TECHNOLOGY CO., LTD

编号: ACQI-DP-RD/028
版次: A0

产品规格书—IFP33173166-100Ah
Product Specification For IFP33173166-100Ah

4 Cell type and size 电池型号及尺寸

4.1 Description and model 电池说明及型号

Description: Square Li-ion rechargeable cell

Model: IFP33173166-100Ah

IFP33173166-100Ah 型号的方形锂离子二次电池

Product Model Meaning 产品型号含义:

IFP33173166-100Ah

IF P XX XXX XXX -100Ah

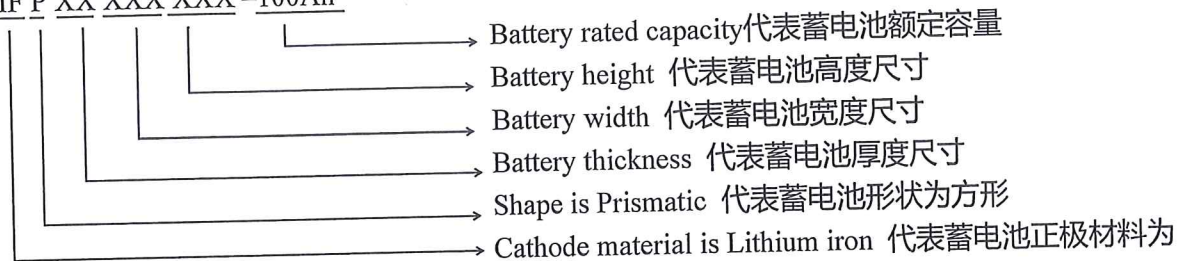

磷酸铁锂

4.2 Cell size (Including blue film) 电池尺寸 (包括蓝膜)

ITEM 电池项目	Parameter 参数
Battery width 电池宽度 (mm)	173.9±0.5
Battery height 电池高度 (No Pole 不包含极柱, mm)	166.8±0.5
Battery height 电池高度 (Including Pole 包含极柱, mm)	170.1±0.5
Battery thickness 电池厚度 (200N/100%SOC@25°C, mm)	33.4±0.5
Battery thickness 电池厚度 (200N/15%SOC@25°C, mm)	32.9±0.5
Positive pole edge to shell edge 正极柱边缘到壳体边缘(mm)	16.4±0.5
Pole size 极柱直径(mm)	21.89
Pole distance 极板间距(mm)	117.3±0.5

Destructive processing, such as polishing and laser welding, is prohibited in other areas except those demonstrated in the area of welding; The welding temperature at the terminal bottom side should be below 120°C.

除所示可焊接区域范围, 其他区域禁止进行破坏式的加工处理, 如打磨、激光焊接等; 焊接过程中, 极柱包胶边缘温度不能超过120°C。





江西安驰新能源科技有限公司
JIANGXI ANCHI NEW ENERGY TECHNOLOGY CO., LTD

编号: ACQI-DP-RD/028
版次: A0

产品规格书—IFP33173166-100Ah
Product Specification For IFP33173166-100Ah

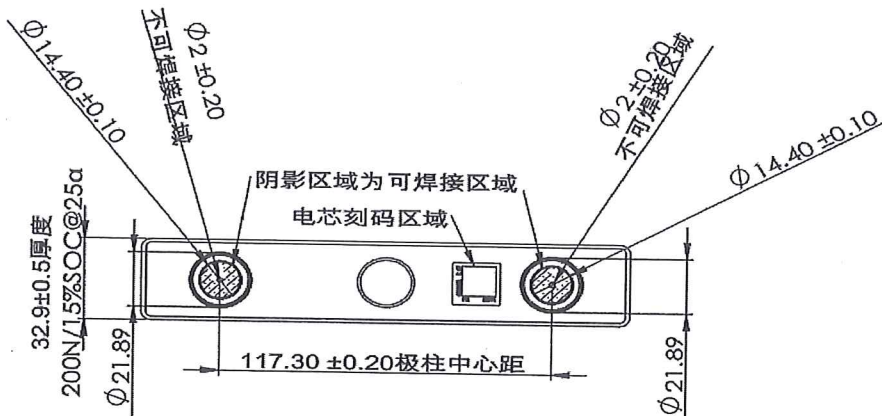
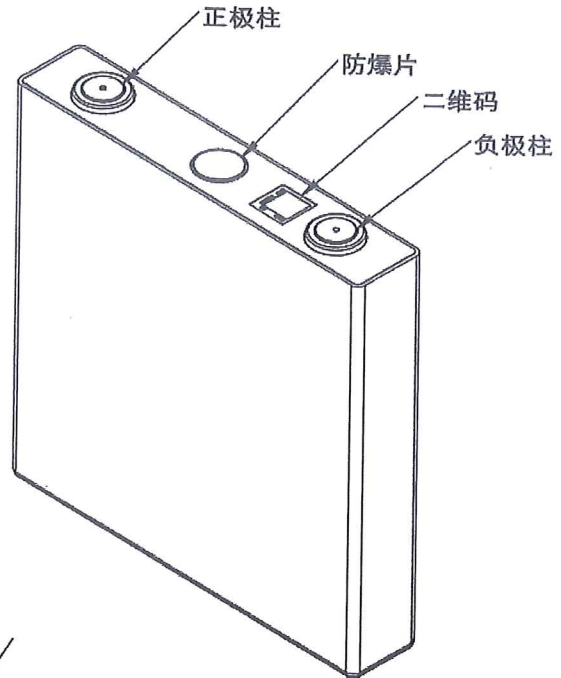
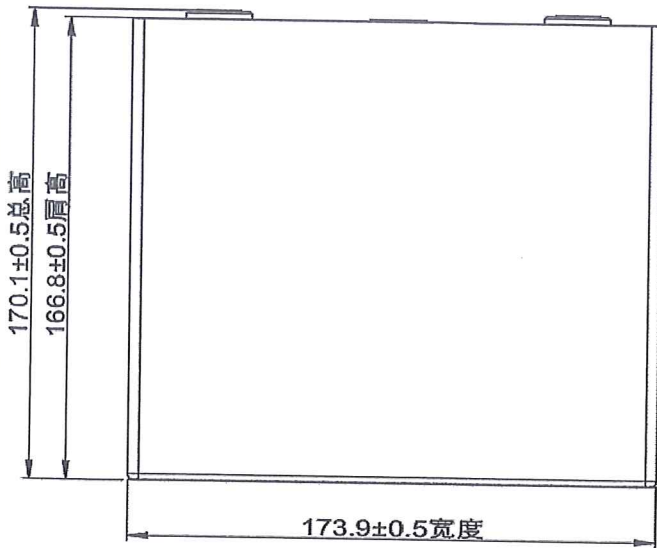

5 Cell parameters and performance 电池参数和性能

5.1 Basic parameters 基本参数

ITEM 项目	SPECIFICATION 规格
Rated capacity 额定容量	100.0Ah
voltage platform.电压平台	3.2V
Limited voltage in charge 最大充电电压	3.65 V
Final voltage in discharge 放电终止电压(温度 > 0°C)	2.50 V
Final voltage in discharge 放电终止电压(温度 ≤ 0°C)	2.00 V
Discharge temperature 放电温度	-30 ~ 60°C
Charge temperature 充电温度	0 ~ 60°C





江西安驰新能源科技有限公司
JIANGXI ANCHI NEW ENERGY TECHNOLOGY CO., LTD

编号: ACQI-DP-RD/028
版次: A0

产品规格书—IFP33173166-100Ah
Product Specification For IFP33173166-100Ah

ITEM 项目	SPECIFICATION 规格
Standard charge and discharge current 标准充放电电流	0.5C/0.5C
Maximum continuous charge and discharge current 最大可持续充放电电流	1C/1C
Maximum pulse (30s) charge and discharge current 最大脉冲充放电电流 (30s)	2C/2C
ACR 交流内阻 (25°C, 15%SOC, 1KHz) mΩ	≤0.45
DCR 直流内阻 (25°C, 50%SOC, 1C/10s) mΩ	≤1.5
Capacity retention 25°C, 100%SOC, 30days 荷电保持 25°C, 100%SOC, 1 个月	≥96%
Capacity retention 60°C, 100%SOC, 7days 荷电保持 60°C, 100%SOC, 7 天	≥96%
Shipping capacity 出货容量	15±2Ah (~15%SOC)
Residual capacity loss 月自放电	Per month ≤3% ≤3%/月 (50%SOC, 25±2°C)
Cycle life @25°C, 1C/80%SOH 电池寿命 @25°C, 1C/80%SOH	≥2000 次
Calendar life 日历寿命 (25°C)	≥8 年
End of life 寿命终止	< 80%
Recommend range of SOC 推荐 SOC 范围	10%~90%
Cell safety performance 电池安全性能	Crush/ Over charge/ Over discharge/ Heating/ Free fall etc. 挤压, 过冲, 过放, 加热, 跌落等符合国标要求
Battery weight 电池重量 (Kg)	1.95±0.10
Appearance 外观	No deformation or cracks, no burrs, no drying, no trauma, no dirt, clear and correct marks. 不得有变形、及裂纹, 表面无毛刺、干燥、无外伤、无 污物, 有清晰、正确的标志
Humidity range 湿度范围	0 ~ 85 % RH (non-condensing 不冷凝)
Altitude 应用海拔高度	< 4500m





江西安驰新能源科技有限公司
JIANGXI ANCHI NEW ENERGY TECHNOLOGY CO., LTD

编号: ACQI-DP-RD/028
版次: A0

产品规格书—IFP33173166-100Ah
Product Specification For IFP33173166-100Ah

5.2 Performance 性能

5.2.1 Different Temperature Capacity, Energy Retention Rate 不同温度容量, 能量保持率

ITEM 项目	-30°C	-20°C	-10°C	0°C	10°C	25°C	35°C	45°C	55°C
容量保持率	≥70%	≥80%	≥85%	≥90%	≥95%	≥100%	≥100%	≥100%	≥100%
能量保持率	≥60%	≥70%	≥75%	≥80%	≥90%	≥100%	≥100%	≥100%	≥100%

Test method: The cell is charged in the standard charge method, then 1C constant current discharge to 2.5V (2.0V, ≤0°C) at different temperature.

测试方法: 按照标准充电后, 分别在不同温度搁置直到电池表面温度达到目标温度后, 1C恒流放电至2.5V (0°C以下放电至2.0V)

5.2.2 Continuous Charging current 最大允许持续充电电流表

温度 SOC	T≤0°C	0<T≤5°C	5<T≤10°C	10<T≤15°C	15<T≤40°C	40<T≤45°C	45<T≤50°C	50<T≤55°C	55<T≤60°C	>60°C
≤100%	0C	0.1C	0.2C	0.2C	0.2C	0.2C	0.2C	0.2C	0.2C	0C
≤90%	0C	0.2C	0.2C	0.3C	0.9C	0.6C	0.5C	0.5C	0.2C	0C
≤80%	0C	0.2C	0.2C	0.5C	1C	0.75C	0.5C	0.5C	0.2C	0C
≤70%	0C	0.2C	0.2C	0.5C	1C	0.75C	0.75C	0.6C	0.2C	0C
≤60%	0C	0.2C	0.2C	0.5C	1C	0.75C	0.75C	0.6C	0.25C	0C
≤50%	0C	0.2C	0.3C	0.6C	1C	1C	0.75C	0.6C	0.25C	0C
≤40%	0C	0.2C	0.3C	0.6C	1C	1C	0.75C	0.6C	0.25C	0C
≤30%	0C	0.2C	0.4C	0.6C	1C	1C	0.75C	0.6C	0.25C	0C
≤20%	0C	0.2C	0.4C	0.8C	1C	1C	0.75C	0.6C	0.25C	0C
≤10%	0C	0.2C	0.6C	0.8C	1C	1C	0.75C	0.6C	0.25C	0C
5%	0C	0.2C	0.6C	0.8C	1C	1C	0.75C	0.6C	0.25C	0C





江西安驰新能源科技有限公司
JIANGXI ANCHI NEW ENERGY TECHNOLOGY CO., LTD

编号: ACQI-DP-RD/028
版次: A0

产品规格书—IFP33173166-100Ah
Product Specification For IFP33173166-100Ah

5.2.3 Maximum pulse charging current 最大允许脉冲充电/制动回馈电流 (30s)

温度 SOC	T≤0°C	0<T≤ 5°C	5<T≤ 10°C	10<T≤ 20°C	20<T≤ 25°C	25<T≤ 35°C	35<T≤ 45°C	45<T≤ 55°C	55<T≤ 60°C	>60°C
100%	0C	0C	0C	0C	0C	0C	0C	0C	0C	0C
95%	0C	0C	0.552C	0.552C	0.84C	0.84C	0.84C	0.6C	0.05C	0C
90%	0C	0.456C	0.552C	0.552C	1.6C	1.6C	1.2C	0.6C	0.15C	0C
80%	0C	0.456C	0.552C	2C	2C	2C	1.6C	0.6C	0.15C	0C
70%	0C	0.624C	1.2C	2C	2C	2C	1.6C	0.6C	0.15C	0C
60%	0C	0.624C	1.2C	2C	2C	2C	1.6C	0.6C	0.15C	0C
50%	0C	0.624C	1.2C	2C	2C	2C	1.6C	0.6C	0.15C	0C
40%	0C	0.72C	1.2C	2C	2C	2C	1.6C	0.6C	0.15C	0C
30%	0C	0.72C	1.2C	2C	2C	2C	1.6C	0.6C	0.15C	0C
20%	0C	0.72C	1.2C	2C	2C	2C	1.6C	0.6C	0.15C	0C
10%	0C	0.72C	1.2C	2C	2C	2C	1.6C	0.6C	0.15C	0C
5%	0C	0.72C	1.2C	2C	2C	2C	1.6C	0.6C	0.15C	0C
0%	0C	0.72C	1.2C	2C	2C	2C	1.6C	0.6C	0.15C	0C

5.2.4 Maximum pulse charging current 最大允许持续放电电流表

温度 SOC	-30<T≤ -20°C	-20<T≤ -10°C	-10<T≤ 0°C	0<T≤ 5°C	5<T≤ 10°C	10<T≤ 15°C	15<T≤ 35°C	35<T≤ 40°C	40<T≤ 45°C	45<T≤ 50°C	50<T≤ 55°C	55<T≤ 60°C	>60 °C
100%	0.18C	0.24C	0.36C	0.6C	0.8C	0.9C	1C	1C	1C	1C	0.75C	0.15C	0C
95%	0.18C	0.24C	0.36C	0.6C	0.8C	0.9C	1C	1C	1C	1C	0.75C	0.15C	0C
90%	0.18C	0.24C	0.36C	0.6C	0.8C	0.9C	1C	1C	1C	1C	0.75C	0.15C	0C
80%	0.18C	0.24C	0.36C	0.6C	0.8C	0.9C	1C	1C	1C	1C	0.75C	0.15C	0C
70%	0.18C	0.24C	0.36C	0.6C	0.8C	0.9C	1C	1C	1C	1C	0.75C	0.15C	0C
60%	0.18C	0.24C	0.36C	0.6C	0.8C	0.9C	1C	1C	1C	1C	0.75C	0.15C	0C
50%	0.18C	0.24C	0.36C	0.6C	0.8C	0.9C	1C	1C	1C	1C	0.75C	0.15C	0C
40%	0.12C	0.24C	0.36C	0.6C	0.8C	0.9C	1C	1C	1C	1C	0.6C	0.15C	0C
30%	0.12C	0.24C	0.36C	0.6C	0.8C	0.9C	1C	1C	1C	1C	0.6C	0.15C	0C
20%	0.12C	0.24C	0.36C	0.6C	0.7C	0.7C	0.7C	0.7C	0.7C	0.7C	0.6C	0.15C	0C
15%	0.12C	0.24C	0.36C	0.36C	0.36C	0.36C	0.36C	0.36C	0.36C	0.36C	0.6C	0.15C	0C
10%	0.06C	0.12C	0.24C	0.36C	0.36C	0.36C	0.36C	0.36C	0.36C	0.36C	0.36C	0.12C	0C
5%	0.06C	0.12C	0.24C	0.24C	0.36C	0.36C	0.36C	0.36C	0.36C	0.36C	0.36C	0.06C	0C
0%	0C	0C	0C	0C	0C	0C	0C	0C	0C	0C	0C	0C	0C





江西安驰新能源科技有限公司
JIANGXI ANCHI NEW ENERGY TECHNOLOGY CO., LTD

编号: ACQI-DP-RD/028
版次: A0

产品规格书—IFP33173166-100Ah
Product Specification For IFP33173166-100Ah

5.2.5 Maximum Pulse Discharge Current 最大允许脉冲放电电流表 (30s)

温度 SOC	-30<T≤ -20°C	-20<T≤ -10°C	-10<T≤ 0°C	0<T≤ 5°C	5<T≤ 10°C	10<T≤ 15°C	15<T≤ 35°C	35<T≤ 40°C	40<T≤ 45°C	45<T≤ 50°C	50<T≤ 55°C	55<T≤ 60°C	>60 °C
100%	0.7C	1.3C	1.75C	1.75C	2C	2C	2C	2C	1.75C	1.5C	1C	0.33C	0C
95%	0.7C	1.3C	1.75C	1.75C	2C	2C	2C	2C	1.75C	1.5C	1C	0.33C	0C
90%	0.7C	1.3C	1.75C	1.75C	2C	2C	2C	2C	1.75C	1.5C	1C	0.33C	0C
80%	0.7C	1.3C	1.75C	1.75C	2C	2C	2C	2C	1.75C	1.5C	1C	0.33C	0C
70%	0.56C	1.2C	1.75C	1.75C	2C	2C	2C	2C	1.75C	1.5C	1C	0.33C	0C
60%	0.56C	1C	1.5C	1.5C	2C	2C	2C	2C	1.75C	1.5C	1C	0.33C	0C
50%	0.42C	1C	1.3C	1.3C	2C	2C	2C	2C	1.5C	1.5C	1C	0.33C	0C
40%	0.42C	1C	1.2C	1.2C	2C	2C	2C	2C	1.5C	1.5C	1C	0.33C	0C
30%	0.28C	0.8C	1C	1C	1.3C	2C	2C	2C	1.3C	1.3C	1C	0.33C	0C
20%	0.14C	0.7C	1C	1C	1.2C	1.5C	1.5C	1.5C	1.2C	1.2C	0.8C	0.33C	0C
15%	0.14C	0.48C	0.48C	0.48C	0.56C	0.56C	0.56C	0.56C	0.56C	0.56C	0.8C	0.33C	0C
10%	0.14C	0.48C	0.48C	0.48C	0.56C	0.56C	0.56C	0.56C	0.56C	0.56C	0.56C	0.33C	0C
5%	0.14C	0.16C	0.27C	0.27C	0.39C	0.39C	0.39C	0.39C	0.39C	0.39C	0.39C	0.33C	0C
0%	0C	0C	0C	0C	0C	0C	0C	0C	0C	0C	0C	0C	0C

6 Storage and quality guarantee period 存储, 保质期

6.1 对于不同的存储环境下, 建议存储条件参照下表:

Temperature 环境温度	Storage time 存储时间	SOC 荷电状态
-10~45°C	≤3 个月	10%≤SOC≤15%

Shelf life: calendar life of 8years or cycle life of 2000 times (based on first come)

保质期: 日历寿命8年或循环寿命2000次 (以先到为准)

Regular maintenance 定期维护

For storage cores that have been used for more than 3 months, the starting time is the delivery time of our cores; if regular maintenance is required, 0.5C current constant charging should be carried out to 3.65V, 3.65V constant voltage to 0.05C, 0.5C constant current discharging to 2.5V after 30 minutes, 0.5C constant current charging to 3.42V(~50%SOC) after 30 minutes, 3.42V constant voltage charging to 0.05C, and the process ends. If abnormal cores are found in the maintenance process, we should contact our company to deal with them in time.

对于使用方库存超过3个月的电芯, 起始时间为我司电芯出货时间; 如需进行定期维护, 需进行0.5C电流恒流充电至3.65V, 3.65V恒压至0.05C, 静置30min后使用0.5C恒流放电至2.5V, 静置30min后再使用0.5C恒流充电到3.42V(~50%SOC), 3.42V恒压充电至0.05C, 流程结束。如维护过程中发现有异常电芯, 需及时联系我司进行处理。

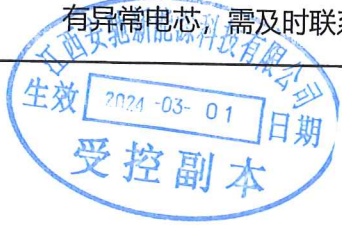



江西安驰新能源科技有限公司
JIANGXI ANCHI NEW ENERGY TECHNOLOGY CO., LTD

编号: ACQI-DP-RD/028
版次: A0

产品规格书—IFP33173166-100Ah
Product Specification For IFP33173166-100Ah

7 Usage and test 电池使用及测试注意事项

7.1 Description of service condition: safety test, cycle life test and pack design need to add preload force, and the range of preload force of fresh cell is 500N~3000N, the recommended preload force is 2000±500N.

使用条件说明: 安全测试、寿命测试、系统成组设计需要施加预紧力, 新鲜电池的预紧力范围为500N~5000N, 推荐的预紧力为2000±500N

7.2 The cell will generate swelling force during attenuation. It is suggested that 1.0~1.5 mm Gap be reserved for the cell assembly module.

产品在使用过程中会产生膨胀力, 建议客户在产品设计中考虑电池成组预留1.0~1.5mm的间隙。

7.3 This cell is designed to service with a finite life time. The customer shall develop and implement an active tracking system to monitor and record impedance of each Product in its entire service life. Customer shall stop using any of the products when its resistance exceeds 200% of its internal resistance or its capacity fading to 80% of typical capacity @25°C.

由于电池的生命周期是有限的, 客户应当建立有效的跟踪系统监测并记录每个电池在使用期限内的容量及内阻。当内阻超过该电池初始内阻的200%或容量降低至初始容量的80%以下(25°C环境下), 应立即停止使用该电池。

7.4 When the Products are intended to be stored for a prolonged period of time (more than one month), the SOC of cells should be adjusted to around 15% periodically (every three months is recommended). For cell, the recommend period to recharge is 3 months at -10~45°C. The SOC cannot be less than 8% for storage, otherwise, ANC will not undertake the responsibility of quality assurance.

若需长期存储电池(超过一个月), 建议将电池SOC调整为15%左右。单体电池, 在-10~45°C环境下的存储周期为3个月。存储过程中, 电池SOC不得低于8%, 否则ANC不承担质量保证责任。

7.5 Customer shall procure that each product shall be used under the strict monitor, control and protection by the BMS. When the cell is first used, it must be fully charged and discharged according the standard charge/discharge method to activate it.

客户在使用电池过程中应通过电池管理系统严密监控和保护每个电池。当电池首次被使用时, 应按照标准充放电规定的方法对电池进行激活, 以保证后续使用过程中电池的容量能够充分发挥。

7.6 Customer shall keep relevant records of the BMS monitoring data throughout the entire service life of each product, including keeping record of number of occurrence of rush charge, which could be used in the determination and judgment of any product warranty and liability claim entitlement. No warranty or liability claim should be considered without BMS diagnosis records (at a regular basis, esp. during maintenance) of the relevant product.

客户应保存完整的电池运行使用记录数据, 包括时间、电压、电流、温度、容量等, 用作产品质





江西安驰新能源科技有限公司
JIANGXI ANCHI NEW ENERGY TECHNOLOGY CO., LTD

编号: ACQI-DP-RD/028
版次: A0

产品规格书—IFP33173166-100Ah
Product Specification For IFP33173166-100Ah

量责任划分的参考。不具备完整的电池系统使用期限内监测数据的情况下, 我司不承担产品质量保证责任。

7.7 The BMS shall include the following monitoring and control features as a minimum requirement:

电池管理系统应最少保证以下基本检测和控制要求:

No . 序号	Parameter 参数	Specification 规格	Action 动作
7.7.1	Stop charging 充电终止	3.65V	Stop charging BMS申请终止充电
7.7.2	First overcharge protection 第一级过充保护	3.7V(MAX) 最大3.7V	Stop charging BMS强制终止充电
7.7.3	Second overcharge protection 第二级过充保护	3.8V(MAX) 最大3.8V	The BMS is forced to terminate charging, and the BMS should be locked until the technician solve the problem. BMS强制终止充电并锁定直至技术人员解决相关问题
7.7.4	First over discharge protection 第一级过放保护	2.8V	Power limitation BMS限制功率
7.7.5	Second over discharge protection 第二级过放保护	2.7V(MIN) 最小2.7V	Power limitation BMS限制功率
7.7.6	Stop discharging 放电终止	2.5V(MIN) 最小2.5V	The cell should be charged back to 30%~50%SOC at 0.2C in time, and the BMS should be locked until the technician solve the problem. 当电池电压低于2.5V时, BMS强制终止放电并被锁定直至技术人员解决问题, 同时立即以0.2C充电至30%~50%SOC。
7.7.7	Short circuit protection 短路保护	No short circuit allowed 不允许短路	The cell should be disconnected by the over current protection device 发生短路时, 需由过流保护装置断开电池

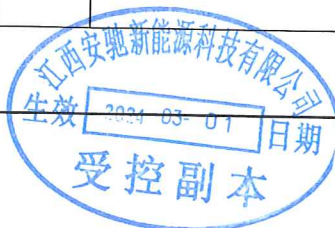



江西安驰新能源科技有限公司
JIANGXI ANCHI NEW ENERGY TECHNOLOGY CO., LTD

编号: ACQI-DP-RD/028
版次: A0

产品规格书—IFP33173166-100Ah
Product Specification For IFP33173166-100Ah

No. 序号	Parameter 参数	Specification 规格	Action 动作
7.7.8	Over current protection 过流保护	Refer to 5.2 参照第5.2条	Control discharge current by BMS to values within specification BMS应控制电流符合规格书规定的电流范围。
7.7.9	Over temperature protection 过温保护	Refer to 5.1 参照第5.1条	Stop charging and discharging when temperature exceeds specification 超过规格书规定的温度范围, 应停止充放电

7.8 The design of the electric box must fully consider the water proof and dust proof problems of the cells. The electric box must meet the water proof and dust proof grade stipulated by the relevant national standards.

箱体在设计过程中应充分考虑电池的防水及防尘问题, 箱体必须满足UL和IEC有关标准规定的防水、防尘等级。若出现因箱体防尘或防水问题导致的电池的损坏(如腐蚀、生锈), 我司不承担质量保证责任。

7.9 It is forbidden to mix different type cells in the same battery system.

禁止将不同类型的电池在同一个电池系统内使用, 否则ANC不承担质量保证责任。





江西安驰新能源科技有限公司
JIANGXI ANCHI NEW ENERGY TECHNOLOGY CO., LTD

编号: ACQI-DP-RD/028
版次: A0

产品规格书—IFP33173166-100Ah
Product Specification For IFP33173166-100Ah

8 Warning and cautions 电池使用时警告事项

To prevent the possibility of the cell from leaking, heating, explosion, please observe the following precautions:

为防止电池可能发生泄露, 发热, 爆炸, 请注意以下预防措施:

- Don't immerse the cell in water.
- 严禁将电池浸入水中。保存不用时, 应放置在阴凉干燥的环境中。
- Don't use and leave the cell near a heat source, such as fire or heater.
- 禁止将电池在高温源旁使用和留置, 如火, 加热器等旁边。
- Don't discard the cell in fire or heater.
- 禁止将电池丢入火或加热器中。
- Don't connect the positive and negative terminal directly with metal objects.
- 禁止用金属直接连接电池正负极, 造成短路。
- Don't transport and store the cell together with metal objects such as necklaces, hairpins.
- 禁止将电池与金属, 如发卡、项链等一起运输或存储。
- strike, throw or trample the cell.
- 禁止敲击, 抛掷或踩踏电池等。
- Don't directly solder the cell.
- 禁止直接焊接电池。
- Don't pierce the cell with a nail or other sharp object.
- 禁止用钉子或其它利器刺穿电池。
- Don't invert the cell.
- 禁止电池倒置。

Caution 小心

- If the cell leaks and the electrolyte get into your eyes, don't wipe eyes, instead, thoroughly rinse the eyes with clean running water for at least 15 minutes, and immediately seek medical attention. Otherwise, eye injury can result.
- 如果电池发生泄露, 电解液进入眼睛, 请不要搓揉, 应用清水冲洗眼睛15分钟以上, 必要时请立即前往医院接受治疗, 否则会伤害眼睛。
- If the cell gives off an odor, generates heat, becomes discolored or deformed, or in any way appears abnormal during usage, recharging or storage, immediately remove it from the device or cell charger and stop using it.
- 如果电池发出异味, 发热, 变色, 变形或使用、存储、充电过程中出现任何异常现象, 立即将电池从装置或充电器中移开并停用。





9 Disclaimer 免责声明

9.1 If the product demand unit does not use the cell according to the provisions of this specification, all responsibility borne by the product demand in case of any problems with the cell, and ANC will not undertake the responsibility.

如果产品需求单位不按照本规格书的规定进行使用, 如果电芯出现任何问题, 所有责任由产品需求单位承担, ANC将不承担任何责任。

9.2 If the product demand unit does not use the product according to the provisions of this specification, causing social impact and affecting the reputation of ANC, ANC will investigate the responsibility of the product demand unit.

如果由于产品需求单位不按照本规格书规定的条件进行使用而造成不良社会影响并影响ANC声誉的, ANC将会追究产品需求单位的责任。

9.3 All other documents of the product related with this product specification must comply with the requirements of this specification. In case of any conflict with this specification, the contents of this specification shall prevail.

本规格书所涉及到的其他产品相关文件所规定的内容都应符合本规格书中的要求。若存在与本规格书相违背的, 以本规格书规定的为准。

9.4 ANC reserves the right to modify the specifications and performance parameters of the product. The buyer needs to confirm the latest status of the product with ANC in advance before ordering the ANC product.

ANC保留对本产品规格和性能参数修改的权利, 客户在购买ANC产品前, 应提前与ANC确认产品的最新状态。

9.5 English specifications are for reference only. Please refer to the technical specifications of the Chinese version.

英文规格释义仅供参考, 请以中文版技术规格要求为准。



