

DCS3-4C080W(120W)-24PS

Machine vision light controller operating instructions

Version: V1.0

Content

1. Controller Classification and Naming	1
2. Specifications	2
3. Main Fuctions	3
4. Instructions and Operations	5
5. Dimensions	12
Accessory List	12

1、 Controller Classification and Naming

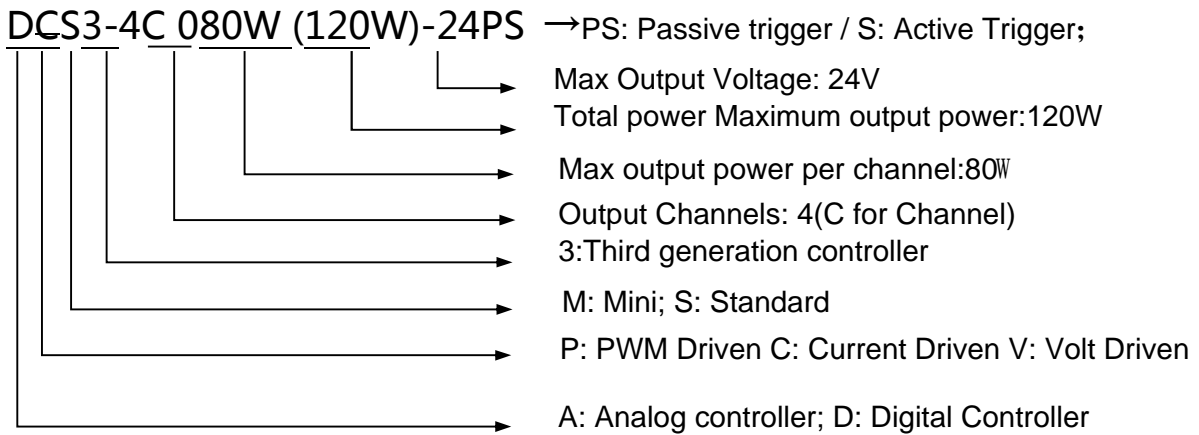

Standard Controller: Supply voltage is AC100~220V

MiniController: Supply voltage is DC24V

Passive trigger: Transmit state signal to the controller channels to trigger and control it from outside.

Active Trigger: Externally trigger the channel switch to ON / OFF (open circuit or short circuit triggers the channel pins).

2、Specifications

Features	Values	Description
Control Mode	constant current	
Input Voltage	AC100-240V	-
Channels	4	-
Manual Control	yes	Adjusted by pressing the key
Remote Control	yes	Communication through RS232 serial port
Brightness Level Memory	yes	Automatic memory starts in 3s after adjustment
RS232 Baud rate	9600	-
Adjustable Brightness Level	0-255 Level	Manual adjustment by encoder or the upper computer software adjustment
Single channel maximum current	3.3A	-
Total output power	120W	-
External triggering mode	Passive trigger	Effective trigger voltage range: 5-24VDC
4 trigger modes	High level trigger	When the rising edge or falling edge is triggered, the lighting duration can be Bit computer software setting, range 1-999ms
	Low level trigger	
	Rising edge trigger	
	Falling edge trigger	
External trigger delay time	H, ON → OFF < 80us	H:High level trigger; ON and OFF represent the on and off state of LED light
External trigger frequency	< 1/T	Determined by light strobing frequency, if T= 1ms, the maximum external trigger frequency is 1KHz.
Short-circuit protection	yes	In case of short circuit, the corresponding channel output will be automatically closed
Overcurrent protection	yes	Total over 2.8A, automatically close all channels and display X. Er1 (X is the channel value). Power failure and restart can be recovered
Automatic detection of light power	yes	Manual or command selection on/off this function
Output power regulation	yes	Regulate the output power of each channel through the power level Enclosure Grade 1-25
Working condition	Temperature:-10~50℃	-
	Humidity:20~80%	
Storage environment	Temperature:-20~70℃	-
	Humidity:10~90%	
Stand-by power consumption	< 5W	-
Dimension	115.8*100*163mm	L×W×H

3、 Main Functions

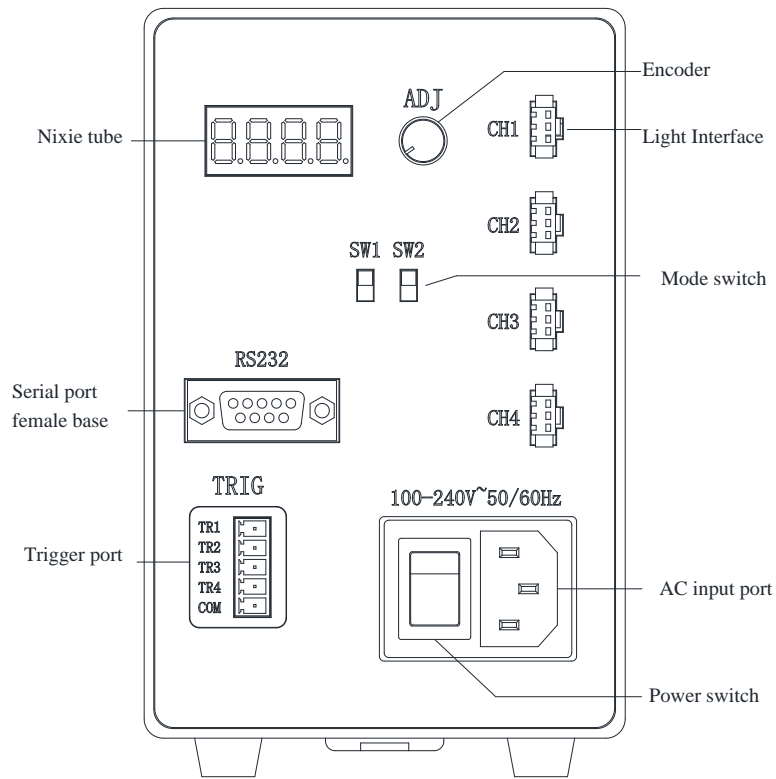

Figure 1 Controller front panel illustration

◆ Nixie tube:

Model	Bit 1 display	Bit 2 display	Bit 3 display	Bit 4 display
Constant light mode	Current channel value	Brightness level (range 0-255)		
Trigger mode		empty		(High level trigger)
		empty		(Low level trigger)
		empty		(Rising edge trigger)
		empty		(Falling edge trigger)
Power level		Current channel value	Power rating (range 1-25)	
Automatic detection of primary light power		empty		(Automatic detection is enabled)
				(Automatic detection is turned off)

◆ **Encoder:** Constant light mode and power level mode: Short press the encoder, the selected bit flashes, and then rotate counterclockwise to decrease the value of the selected bit; Rotate clockwise to increase the selected value. (Note: The power level can only be adjusted when the automatic detection function is turned off)

Trigger mode: Rotate encoder to select different trigger modes.

Automatic detection of primary light power: Rotate the encoder and choose to turn the function NO or OF

◆ Work pattern

Model	Toggle switch SW1	Toggle switch SW2
Constant light mode	up	up
Trigger mode	down	up
Power level	up	down
Automatic detection of primary light power	down	down

◆ Constant light mode

The light is constantly on and the brightness can be manually or remotely adjusted. The external trigger signal is invalid in this mode.

◆ Trigger mode

- ① High level trigger: when the trigger signal is high, the light source is always on; At low levels, the light source goes out.
- ② Low level trigger: when the trigger signal is low, the light source is always on; At high levels, the light source goes out.
- ③ Rising edge trigger: When the external rising edge signal is received, the light source will turn on, and after a certain period of time, it will be automatically extinguished. The illumination duration of the light source can be set by the instruction, ranging from 0-999ms.
- ④ Falling edge trigger: When the external falling edge signal is received, the light source will turn on, and after a certain period of time, it will be automatically extinguished. The illumination duration of the light source can be set by the instruction, ranging from 0-999ms.

◆ Power level

The power level adjustment range is 1-25. When the automatic detection function is off, it can be set manually or remotely. Level 1 \approx 4.8W. Each channel power level is adjusted independently.

◆ Automatic detection of primary light power

① When the function is on, the controller automatically detects a power check for all channels. The digital tube displays X.Er0, indicating that the current channel X is not connected to the light source; After accessing the light source, the controller detects the power of the light source and automatically displays the corresponding brightness level of the channel.

② When this function is off, the power level of each channel can be set.

◆ Brightness memory function

Press the button on the controller panel or the upper computer application software to adjust the brightness level of each channel and stop for 3s. The controller automatically memorizes the brightness level of each channel without loss in case of power failure.

4、Instructions

4.1 Manual manipulation

- Under the constant light mode, shortly press the encoder to select the bit of the nixie tube from left to right. The selected bit will flash. At this time, rotate the encoder to adjust the value of the flashing bit. Increase the value clockwise and decrease the value counterclockwise.
- In trigger mode, no short press is needed to directly rotate the encoder to select trigger mode (all channels are set uniformly).
- Under the power level mode, shortly press the encoder, the first and second digits of the digital tube flash at the same time, and PX is displayed (X represents the current channel value), rotate the encoder to select the corresponding channel; Press the encoder again, bit 3 and bit 4 of the digital tube flash at the same time, and the power level of the channel is displayed (1-25). Rotate the encoder to adjust the power level.
- Automatic detection of primary light power: without short press, directly rotate the encoder to select on or off this function.

4.2 Port definition

- ◆ RS232 serial socket interface is defined as follows:

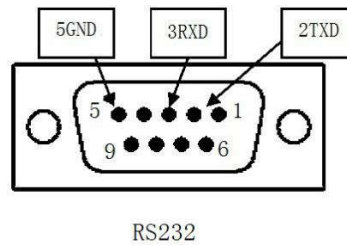

- ◆ Light interface: “CH1”、“CH2” “CH3” “CH4”

Light port output definition:

	Output voltage	Output pin 1	Output pin 2	Output pin 3
	5V	NC	+	-
	12V	+	-	NC
	24V	+	NC	-

- ◆ Trigger Port:

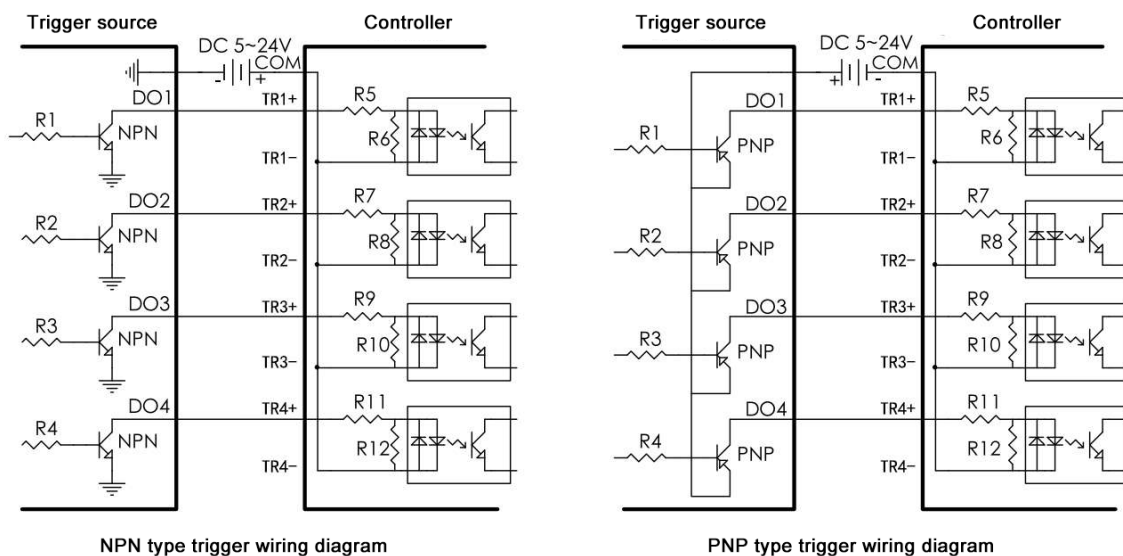

“ TR1” “ TR2” “ TR3” “ TR4” “ COM” is the external trigger access port. Where "COM" is the public side. Trigger effective signal is high level, DC5-24V. The wiring diagram is as follows:

4.3 Remote operation

(1)、Open the "4 channel Light source Controller software V3.0.exe" execution file, the following interface appears:



Figure 2 Software of the upper computer of the controller

(2)、Interface description

◆ Communication status bar

- COM port: Serial port selection, select the COM port to which the controller is connected.
- COMState: Communication status bar, indicating whether the controller is successfully connected to the computer. After clicking "Start Connection", the status is displayed:

1. Serial port connection failed
2. Serial port connection succeeded

◆ Channel brightness control bar

- Channel X(X=1、 2、 3、 4): Indicates the control channel number.
- 0-255: Indicates the brightness level adjustment range. The brightness level of the controller can be adjusted by dragging the position of the slider.
- Communication information: Display the control instructions sent by the host computer to the controller, and the corresponding return value received.

4.4 Communications protocol

Hardware specification

Baud rate	Data length	Stop bit	Parity check
9600 bps	8 bits	1 bit	无

Data format (Frame format)

1 byte	1 byte	1 byte	1 byte	1 byte
Tagged word	Command word	Channel word	Data	Xor and check words

Note: All communication bytes are in ASCII

◆ Tagged word = \$

◆ Command word = 1, 2, 3, 4, 5, 6, 7, 8, 9, 0, A, B.

Defined respectively as:

- 1: Turn on the corresponding channel brightness
- 2: Turn off the corresponding channel brightness
- 3: Set the corresponding channel brightness parameter
- 4: Read the corresponding channel brightness parameters
- 5: Set the corresponding channel power level

- 6: Readout corresponds to the channel power level
- 7: Set all trigger polarities
- 8: Readout all trigger polarities
- 9: Set the corresponding channel trigger pulse width
- 0: Readout the corresponding channel trigger pulse width
- A: Set auto detection on/off
- B: Readout the status of the automatic detection function

In the preceding command word, A or B is case insensitive.

When the command word is 1,2,3,5,7,9, if the controller receives the command successfully, the feature word \$is returned. If the controller fails to receive the command, it returns &.

When the command word is 4,6,8,0, B, if the controller receives the command successfully, it will return the brightness setting parameters of the corresponding channel (the return format is the same as the sending format). If the controller fails to receive the command, it returns &.

When the command word is A, the channel word can be any number without affecting the command function. Switch automatic detection function switch is defined as follows:

Data bits	Model
000	Automatic detection is turned OFF
001	Automatic detection is turned ON

When the command word is 7, the trigger polarity of all channels is set uniformly, and the channel word can be any number without affecting the command function. Switching the four trigger polarities is defined as follows:

Data bits	Model
001	High level trigger
002	Low level trigger
003	Rising edge trigger
004	Falling edge trigger

- ◆ Channel words = 1,2,3,4 represent the four output channels, respectively.
- ◆ Data=XXX,brightness level range(000-0FF);stroboscopic pulse width range(000-3E7).
- ◆ Xor and check word = The XOR checksum of bytes (including: Tagged word, command word, channel word, and data) other than the checkword, with the highest half byte ASCII code first and the lowest half byte ASCII code next.
- ◆ Example: If the first channel brightness is set to 100, then write down "\$3106414" in ASCII code.

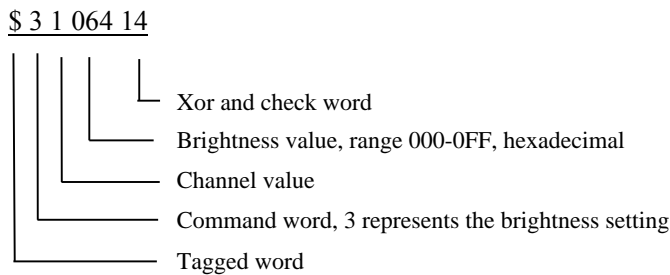

Xor and check word operation process is as follows:

	Character string		ASCII code	ASCII codes are represented in hexadecimal	The high half byte and the low half byte are represented by 8421 codes, respectively
Tagged word	\$		36	24	0010 0100
Command word	3		51	33	0011 0011
Channel word	1	→	49	31	0011 0001
Data	0		48	30	0011 0000
	6		54	36	0011 0110
	4		52	34	0011 0100
Xor sum					0001 0100
Xor check word					1 4

Note: In the operation process of the XOR check word with the eight functions of command word 1, 2, 4, 6, 8, 0, A and B, the value of the three bytes of the data has no effect on the XOR result, and the format is guaranteed to be XXX (XX=000 ~ 0FF any value).

The following are several groups of experimental data. If users write their own Demo program, they can refer to the following data for comparison test

Close channel 2: \$220291f

	Character string		ASCII code	ASCII codes are represented in hexadecimal		The high half byte and the low half byte are represented by 8421 codes, respectively	
Tagged word	\$	→	36	→	24	→	0010 0100
Command word	2		50		32		0011 0010
Channel word	2		50		32		0011 0010
Data	0		48		30		0011 0000
	2	50	32	0011 0010			
	9	57	39	0011 1001			
Xor sum							0001 1111
Xor check word							1 f

Open 3 channel: \$1306414

	Character string		ASCII code	ASCII codes are represented in hexadecimal		The high half byte and the low half byte are represented by 8421 codes, respectively	
Tagged word	\$	→	36	→	24	→	0010 0100
Command word	1		49		31		0011 0001
Channel word	3		51		33		0011 0011
Data	0		48		30		0011 0000
	6	54	36	0011 0110			
	4	52	34	0011 0100			
Xor sum							0001 0100
Xor check word							1 4

Read the 2-channel brightness level parameters: \$4206410

	Character string		ASCII code	ASCII codes are represented in hexadecimal		The high half byte and the low half byte are represented by 8421 codes, respectively	
Tagged word	\$	→	36	→	24	→	0010 0100
Command word	4		52		34		0011 0100
Channel word	2		50		32		0011 0010
Data	0		48		30		0011 0000
	6	54	36	0011 0110			
	4	52	34	0011 0100			
Xor sum							0001 0000
Xor check word							1 0

5、Dimensions

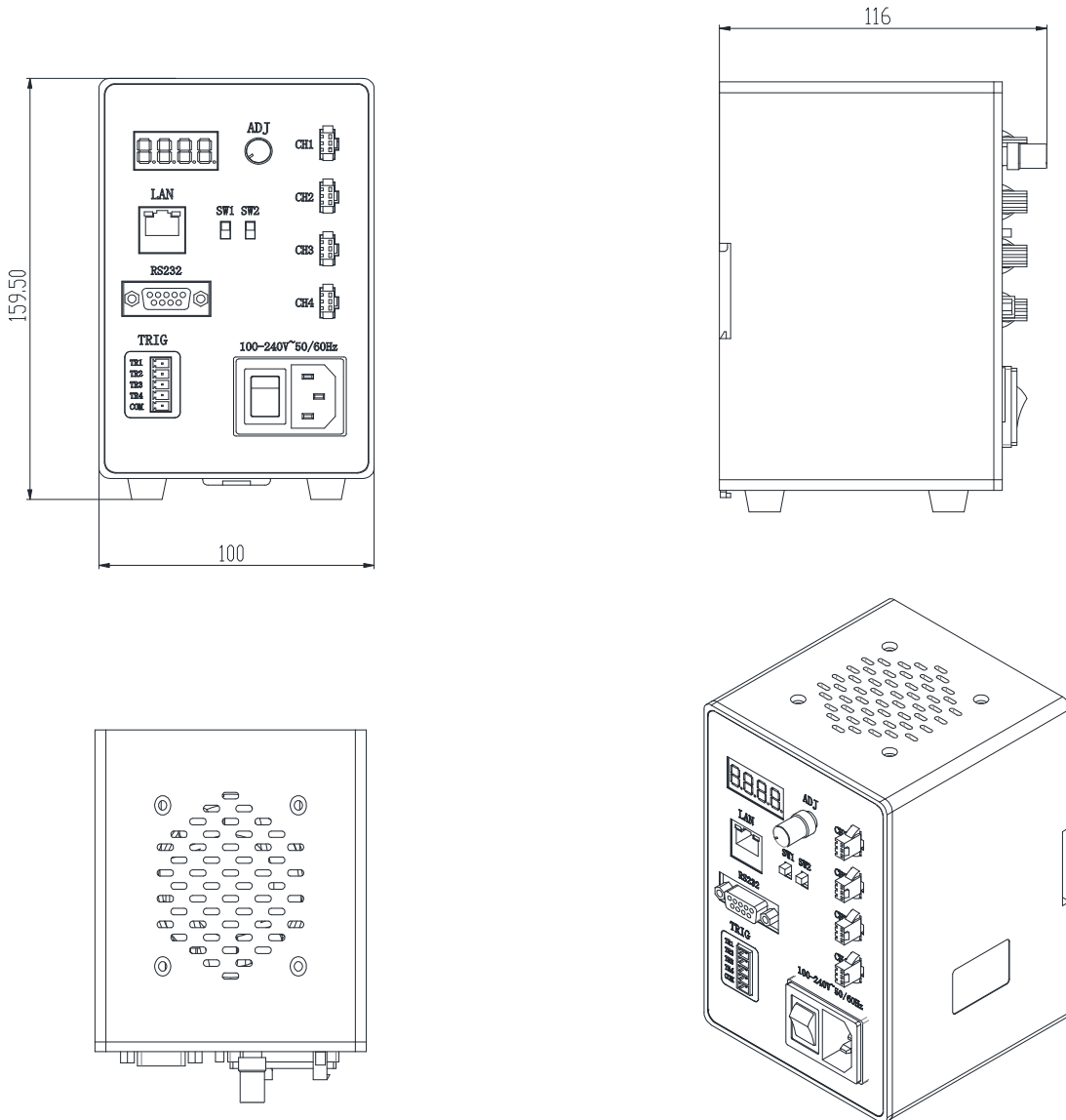

Accessory List

Name	Quantity	Remark
DCS3-4C080W(120W)-24PS controller	1	
RS232serial port line	1	
5PINGreen male terminal	1	