

Smart Optimizer SUNGO iOPT 800W & Data Gateway SUNGO GTC Quick Installation Guide

Document version: SUNGO-iOPT>C™-V1-2024 EN
 Release Date: 2024.5

1 Product Overview

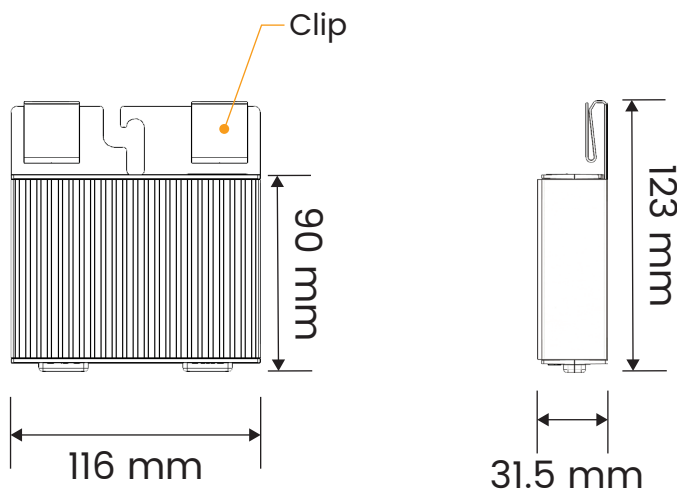

Model Description

SUNGO iOPT 800W
 -Smart PV Optimizer
 -Maximum Input Power 800W

Interface definition

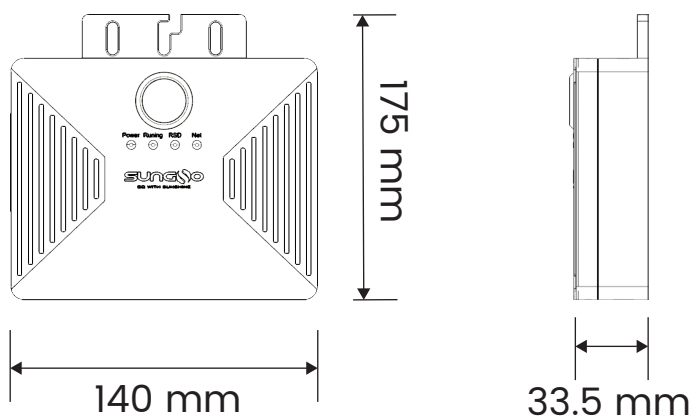
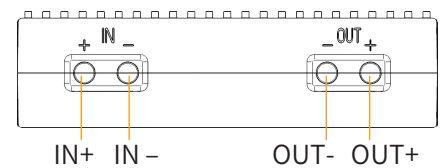

Model Description

SUNGO GTC
 -Data Gateway

2 Install the Intelligent Optimizer iOPT

Step 1.

Before installing the optimizer, make sure the inverter is stopped (DC switch placed in OFF) and disconnect the inverter from the module array.

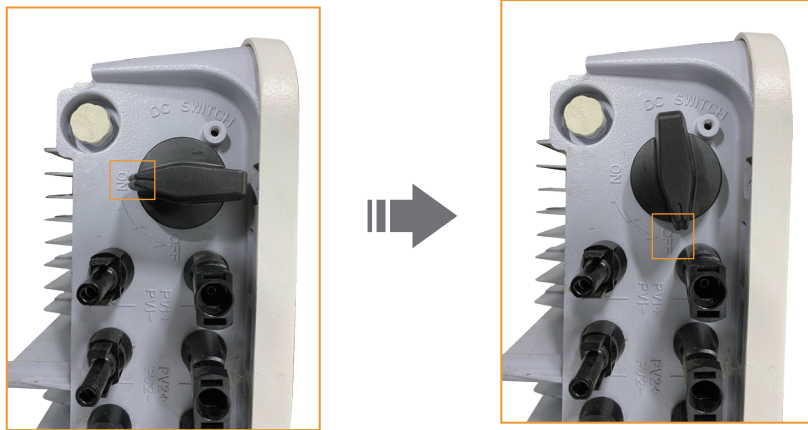

DC switch Placement in OFF position Schematic

Step 2.

Plan the optimizer installation location properly to ensure proper connection of cables between the optimizer, components, and neighboring optimizers.

Optimizer IN+: 200mm exposed IN-: 1100mm exposed OUT+ /OUT-: 750mm

Step 3.

After confirming the installation location of the optimizer and data gateway (Stay close to the strings and away from the inverter), start installing the optimizer and data gateway. At the same time remove the SN label and paste it to the physical layout template.

The optimizer must do the physical location layout, so that when the optimizer location fails, you can find the faulty optimizer location according to the physical location layout diagram to facilitate the replacement of the optimizer.

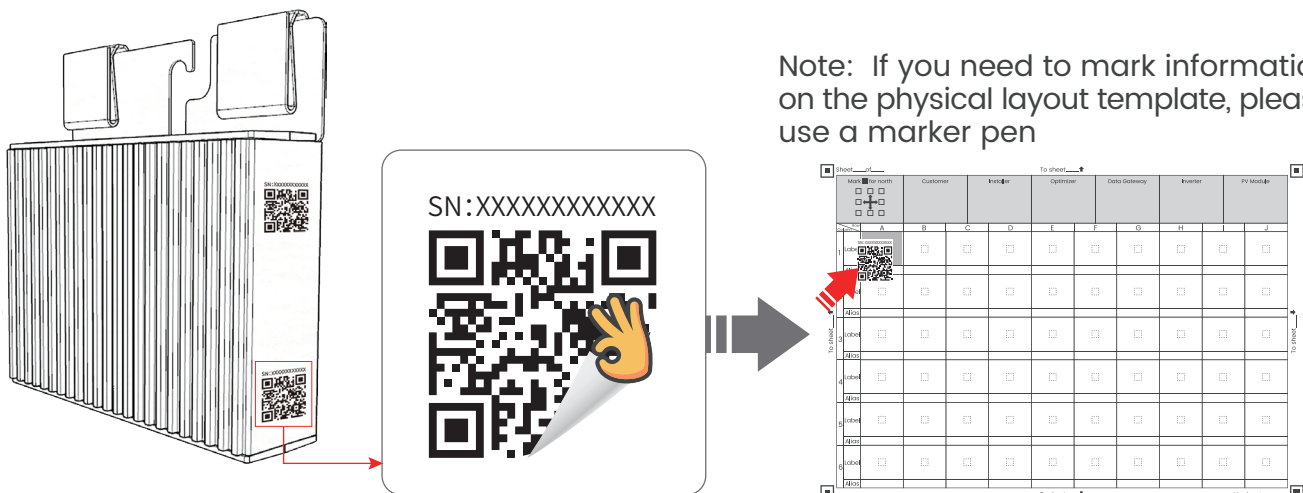

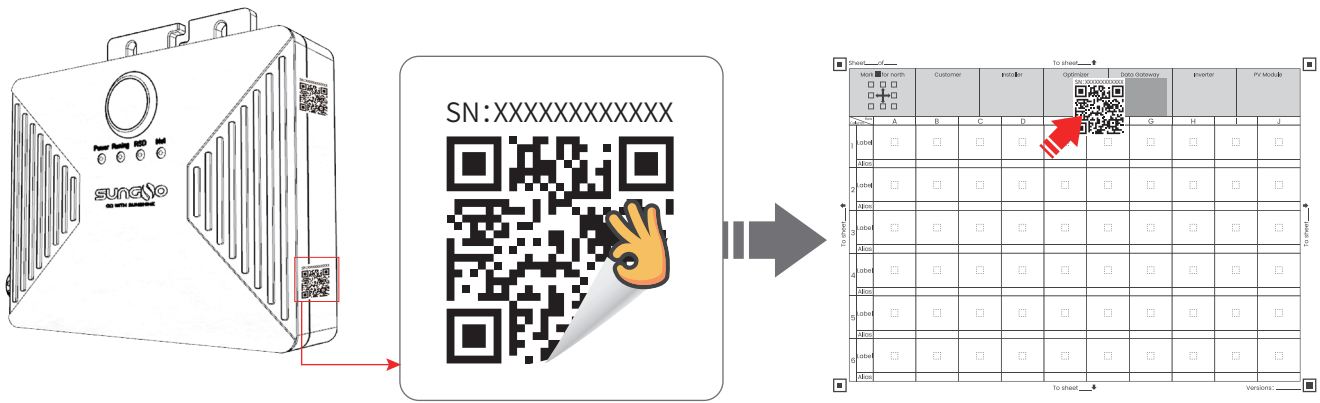

Step 4.

Mounting the optimizer to the PV panel bezel after removing the SN label - backside mounting.

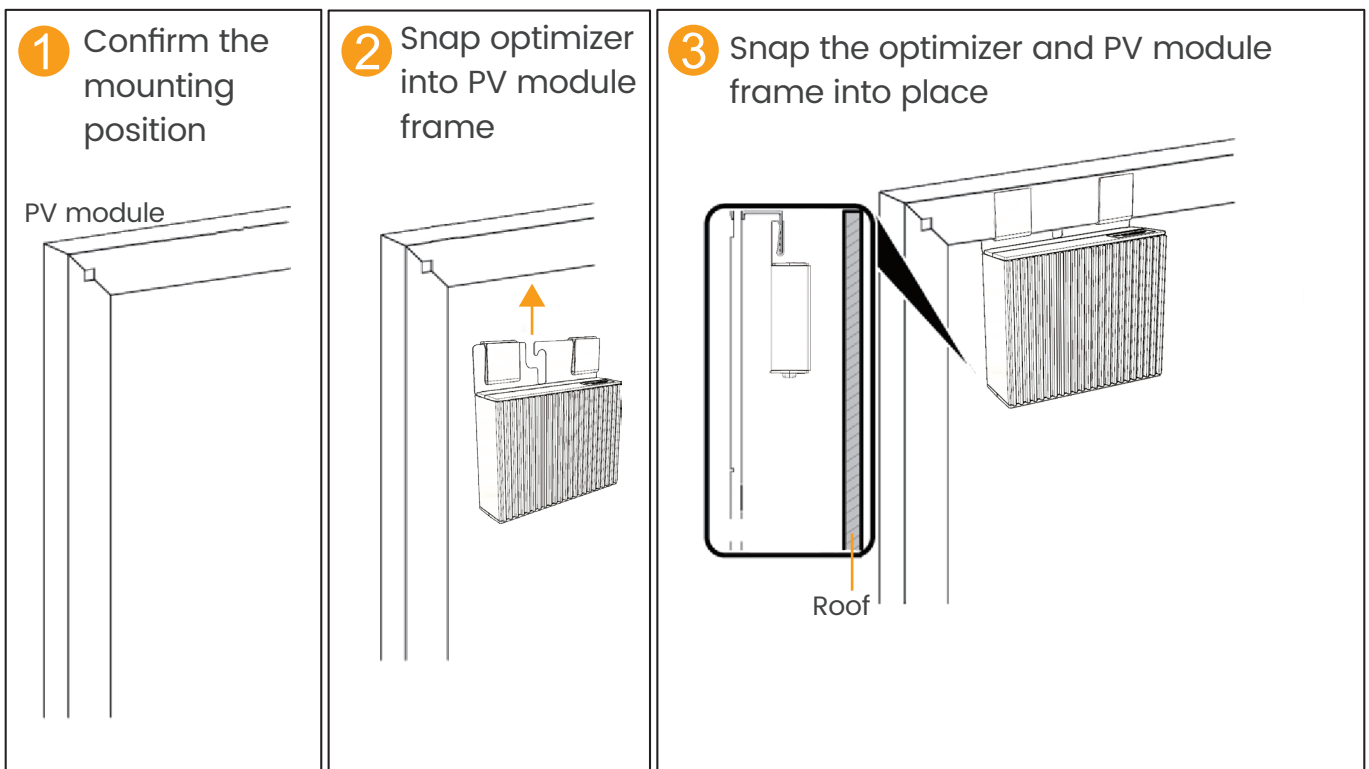

Attach the optimizer to the outer frame on the back of the PV through the clips and snap the clips completely into the frame to complete the installation.

3 Smart Optimizer iOPT Cable Connections

Step 1.

- Install the optimizer cable as shown below, otherwise the optimizer or the PV module may be damaged.

1. Connect the IN+ and IN- of the optimizer to the positive and negative terminals of the PV panel junction box correspondingly.
2. Connect OUT+ of the first optimizer to OUT- of the next optimizer.
3. Connect the cables of the other optimizers sequentially according to steps 1 and 2.

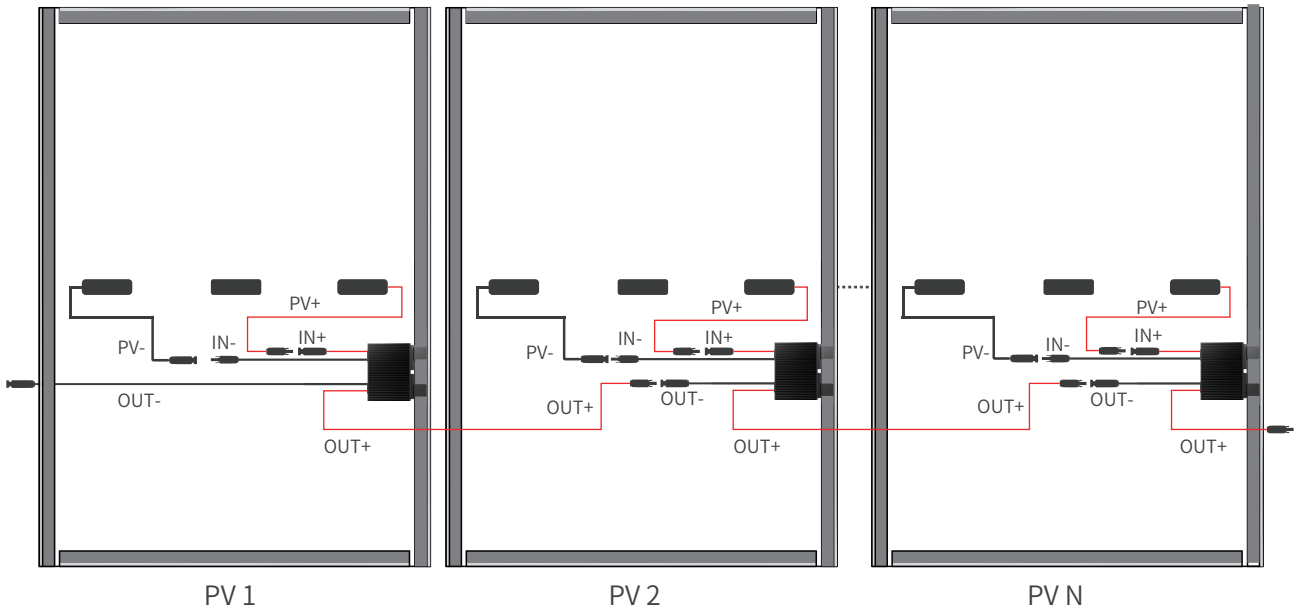

⚠ Caution!

In installation

Input cables of PV optimizer MUST be connected first, output cables of PV optimizer should be connected second.

In disassembly

Output cables of PV optimizer MUST be disconnected first, input cables of PV optimizer should be disconnected second.

Step 2. Optimizer Detection

1. Connect the optimizer input (IN) to the pv junction box.
2. Use the positive pen of the multimeter to connect the positive output of the optimizer, and the negative to connect the negative output, and check the output voltage of a single optimizer.

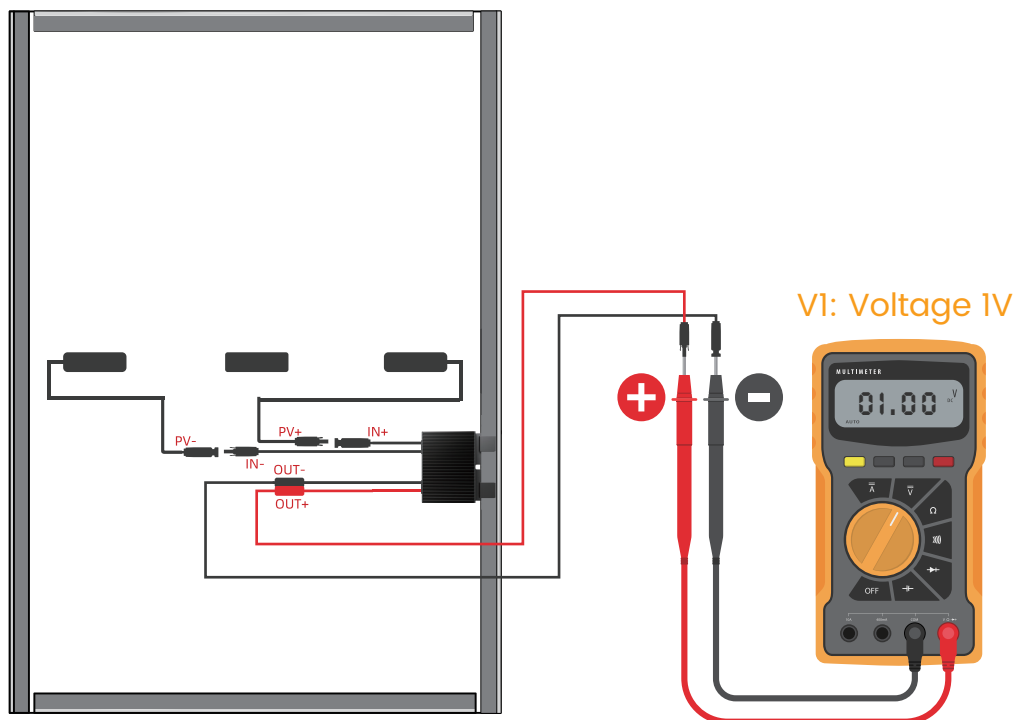

| Voltage | Reason | Solve suggestion |
|--------------------------|---|--|
| $0.9V \leq V1 \leq 1.1V$ | Optimizer normal | — |
| $V1 > 1.1V$ | Optimizer fault | Replacement optimizer |
| $V1 < 0.9V$ | <ul style="list-style-type: none"> Weak light optimizer input is not connected The optimizer is wired incorrectly Optimizer fault | <ol style="list-style-type: none"> Voltage is measured when light is sufficient. Connect the optimizer input cable Adjust the optimizer cable connection and connect the optimizer input cable to the PV module output If the voltage is still abnormal, replace the optimizer |
| $V1 \approx -1V$ | The multimeter pen is reversed | Multimeter pen positive and negative exchange |

3. After confirming that the optimizer and the input cable are properly connected, connect the optimizer output cable. When the light is sufficient, the voltage of the photovoltaic string is measured.

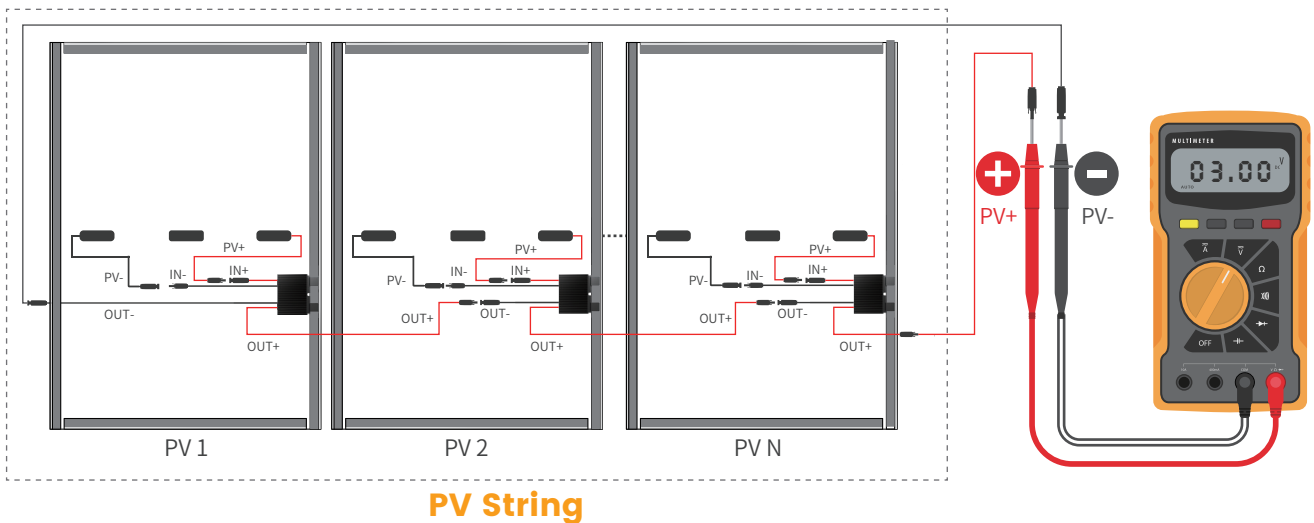

| Voltage | Reason | Solve suggestion |
|---|--|--|
| The string voltage is 0 | <ul style="list-style-type: none"> PV module strings have open circuit The cables are not in the same string | <ol style="list-style-type: none"> Check whether the group string is open circuit faulty Connect the strings cables correctly |
| The string voltage is negative | <ul style="list-style-type: none"> The multimeter pen is reversed The label on the cable is incorrect | <ol style="list-style-type: none"> Multimeter pen positive and negative exchange Make proper cable labels |
| The string voltage is less than the number of optimizers | <ul style="list-style-type: none"> Some optimizer input missed connections Some optimizer outputs miss connections Some optimizer outputs are connected opposite | Check whether the PV modules and strings cables are correctly connected |
| The string voltage is greater than the number of optimizers | <ul style="list-style-type: none"> The actual number of optimizers in the group string is greater than the expected number The photovoltaic panel is not connected to the optimizer, and is directly connected to the group string | <ol style="list-style-type: none"> Check that the number of optimizers in the group string is correct Check whether the PV modules and series cables are correctly connected |

4 Installing the GTC and connecting the strings to the inverter

1. install the GTC near the inverter.
2. connect the OUT+ of the last optimizer to the PV+ of the inverter.
3. Connect the OUT- of the first optimizer to the PV- of the inverter through the magnetic ring of the GTC.
4. After confirming that the connection is correct GTC connects the MCB and then connects it to the AC.

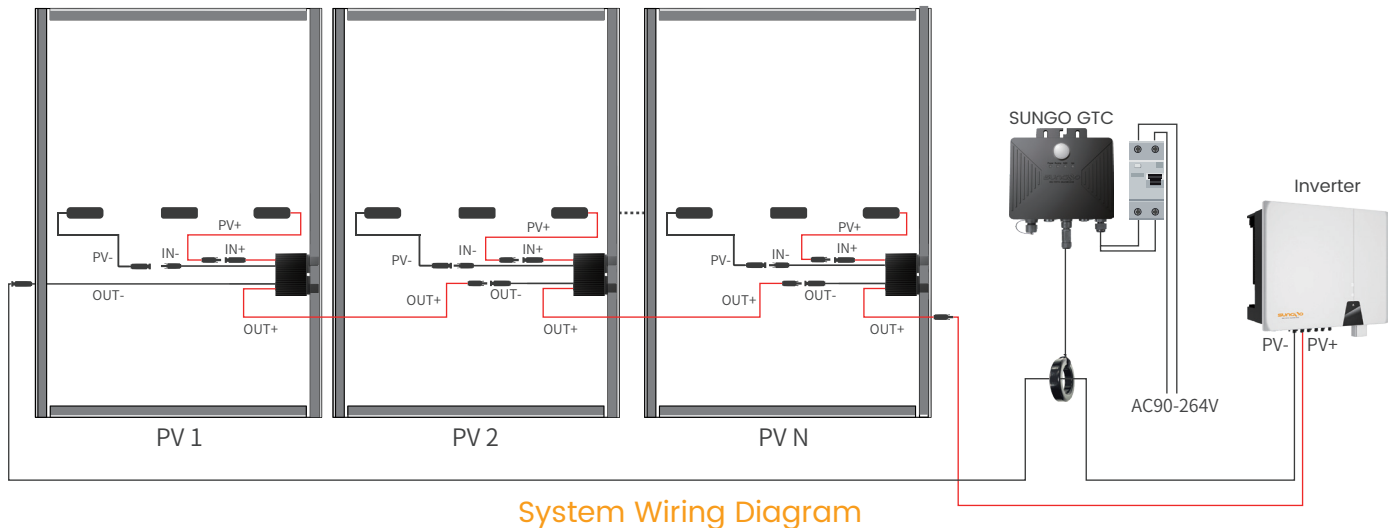

System Wiring Diagram

The GTC itself is IP67 waterproof and can be used without a distribution cabinet. The AC input line is connected to the AC power using the L16-2 waterproof connector.

- Check that the structural mounts are secure and that all screws are tightened.
- Check that all cables are connected with the correct polarity and that the connections are firm and reliable to ensure that there are no short circuits.

5 System power-up and product management

Step 1. Turn on the inverter

Confirm that the system is connected correctly, the inverter DC switch is ON, and the inverter is turned on.

Step 2. Connecting the data gateway to a power source

Connect the data gateway to 90~264V AC power supply. Ensure that the power indicator green light is always on, and the running indicator green light is also always on. Check whether the inverter is working normally.







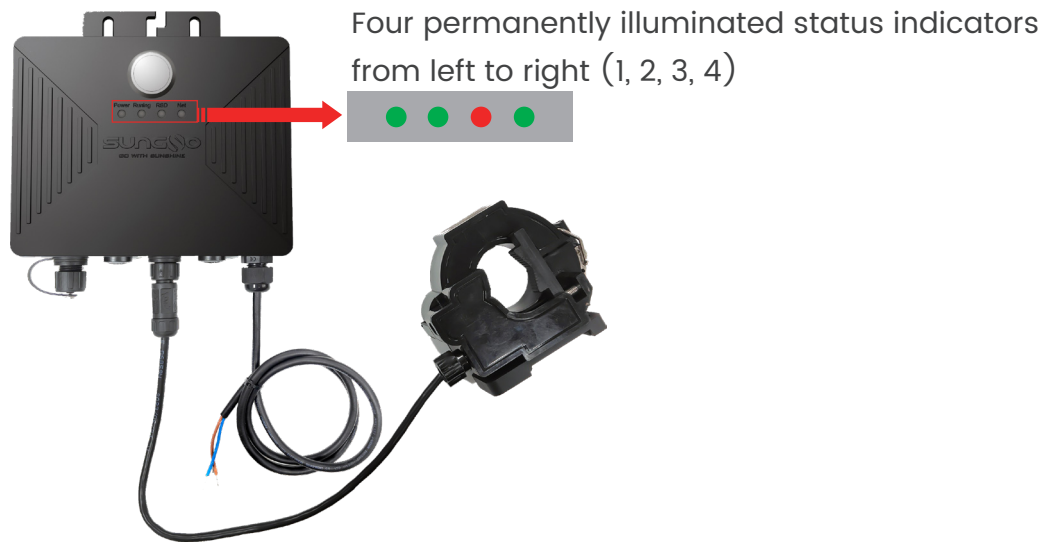

Step 3. GTC status indication

Search Optimizer self-test and indicator status

Press the center button to allow the Running light to illuminate normally. Let the Rapid Shutdown (RSD) go out for an extended period. After 5 seconds, press and hold the button. After a few seconds, the GT enters the self-test mode, and when the 2, 3, 4, indicator light flashes back and forth, release the button. Wait for about 10 minutes until the Running indicator light flashes, indicating a successful self-test. Press the button again to make the Running indicator light continuously on, confirming that the optimizer is operating normally. If the 3 indicator lights are blinking, it signifies a test failure. In such a case, please check the connections and rerun the test. If the test fails three times, kindly contact the relevant technical personnel.



Note: Indicator status indicates

| 1, 2, 4 Indicator status schematic: ● Indicates normally lit ● Indicates extinguished ● Indicates blinking 3 Indicator status schematic: ● Indicates normally lit ● Indicates extinguished ● Indicates blinking | |
|--|--|
|  None of the four indicator lights are lit Wrong or faulty circuit connection |  1 on 2 off 3 on 4 on Turn off the optimizer, the network is connected normally |
|  1, 2 on 3, 4 off Start optimizer, network not connected |  1 on 2 blinking 3 blinking 4 blinking Search Optimizer self-test |
|  1, 2 on 3 off 4 on Start the optimizer, the network is connected normally |  1 on 2Blinking 3on 4 on or off Search Optimizer self-test successful |
|  1 on 2 off 3 on 4 off Optimizer off, network not connected |  1 on 2 off 3 blinking 4 on or off Search Optimizer self-test failed |

Step 4. GTC entry whitelisting

I. Process

Recommended application process:

1. First power up the GT/GTC.
2. Use the USB to RS485 cable to connect GT/GTC and the computer
3. Select the corresponding serial port
4. Read MAC Addr and Version, if normal display, represents the current connection is normal, otherwise check whether the cable is properly connected.
5. Enter the iOPT code into the List list, and then click Write to write it to GT/GTC; there are two ways to enter the code as follows
 - ① Through Import button, recognize the selected picture to import.
 - ② Enter the number manually through the keyboard, and note that each number is separated by a comma.
6. Monitor the current status of the optimizer through To Monitor.

II. Wiring

Use USB to RS485 to connect the GT/GTC to the computer, the connection is shown below:

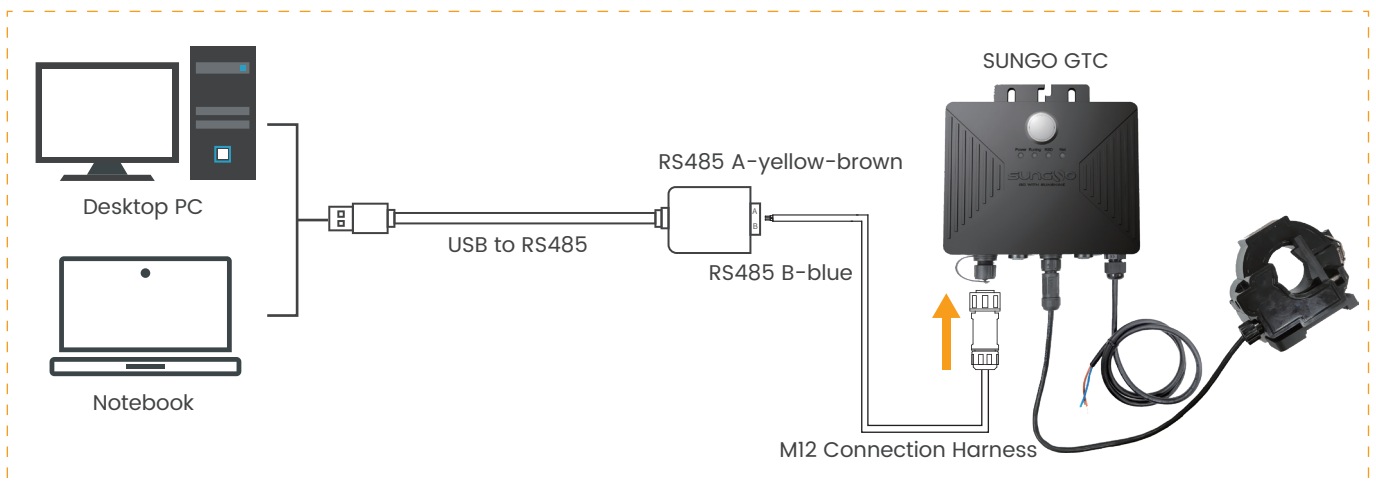

Wiring Diagram

III. Description

1. Select the corresponding serial port

After success, the green circle is displayed as follows

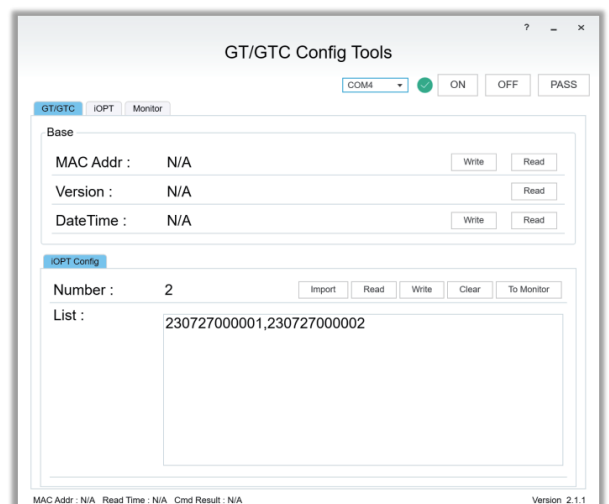
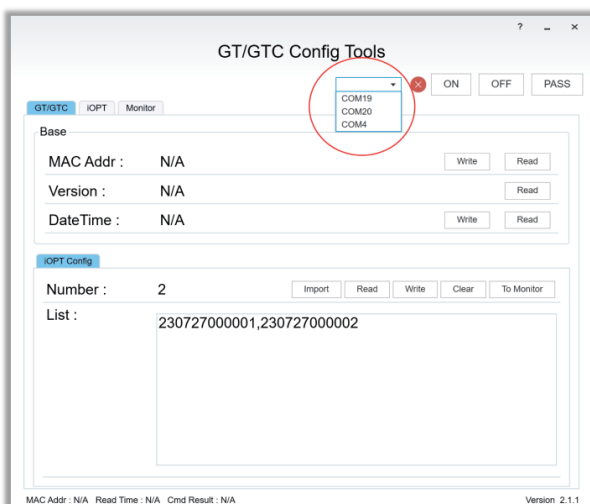

2. Description of GT/GTC functions

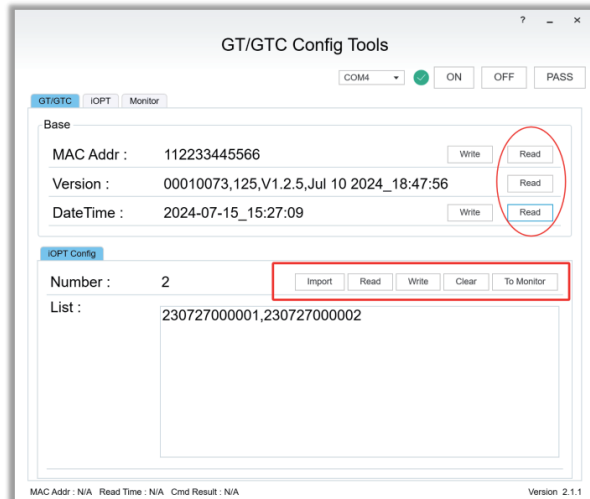

①MAC Addr:

Click Read to read the address of GT/GTC, and click Write to write the address in the left input box to GT/GTC.

②Version

Click Read to read the software version number of GT/GTC.

③DateTime

Click Read to read the time of GT/GTC, and click Write to write the system time into GT/GTC.

④iOPT Config - Import

Click Import to import the iOPT code through the image, as follows
Click Import to import the recognized codes into the List box.

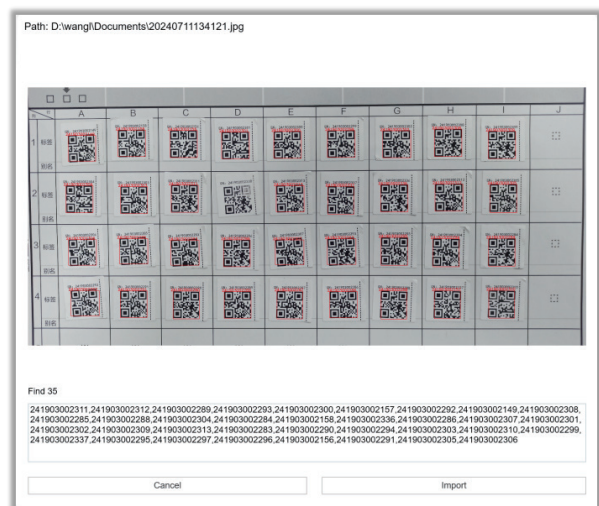
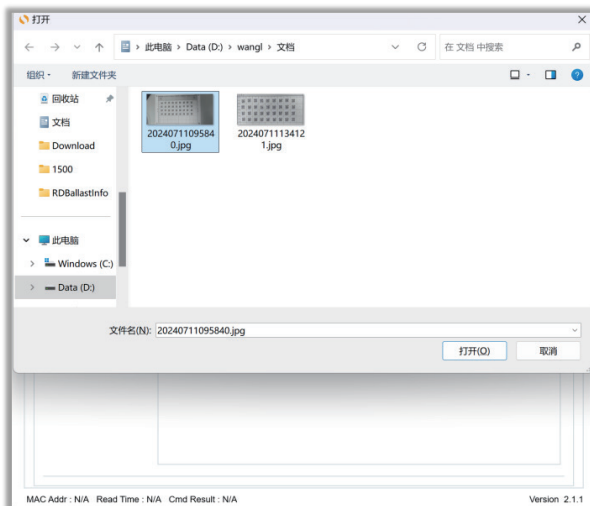

⑤iOPT Config - Read

Click Read to read the iOPT list of the current GT/GTC configuration.

⑥iOPT Config - Write

Click Write to write the iOPT list to GT/GTC.

⑦iOPT Config - Clear

Click Clear to delete all the iOPTs in GT/GTC.

⑧iOPT Config - To Monitor

Click Monitor to display the iOPTs in List on the Monitor page.

3. Read single iOPT working parameters function description

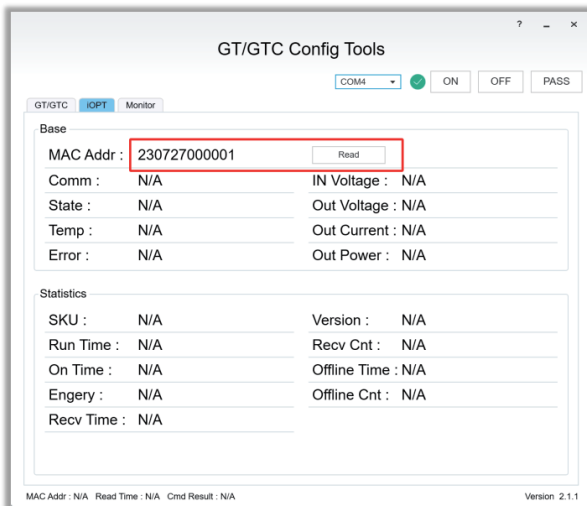

Input the iOPT number you need to read, click Read to read its current status.

Comm: communication status, Online stands for online, Offline stands for offline.

State: current state, ON working, OFF closed.

Temp: current temperature, Celsius degrees

Error: current fault, Normal stands for normal.

IN Voltage: input voltage

Out Voltage: Output Voltage

Out Current: Output Current

Out Power: Output Power

SKU: Product Model

Run Time: Run Time

On Time: Working Time

Engery: Power Generation

Recv Time: Receive Time

4. Monitor Function Description

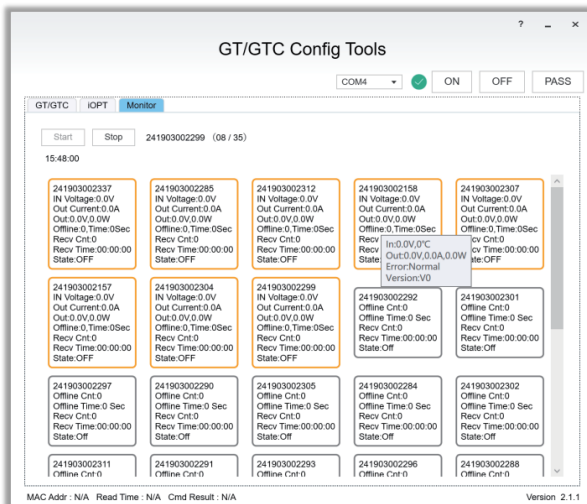

Click Start to start monitoring, the software will refresh the status of iOPT in List regularly.

6 GTC distribution network

Step 1. Download APP and register account



iSungo-Android



iSungo-ios

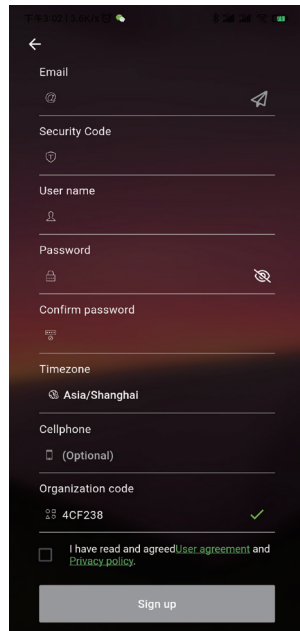

Scan the QR code to download APP

Open the APP to register an account

Step 2. Creation of PV power plants



Click on the top right corner to create a power station

Step 3. Fill in the power station information

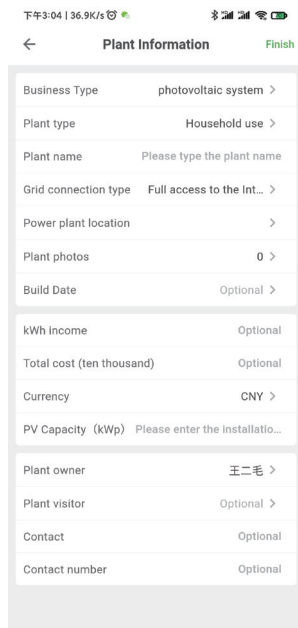

Step 4. Sweeping Code Collection Data Gateway



WiFi Serial Number:
XXXXXXXXXXXXXXXXXX



Example of QR code on the left side of GTC

Click the arrow on the right side of the power station, scroll down, and click 'Add Collector.' Then, scan the WIFI serial number on the left side of the Data Gateway GTC by using the QR Code.

Step 5. GTC WIFI Distribution Network

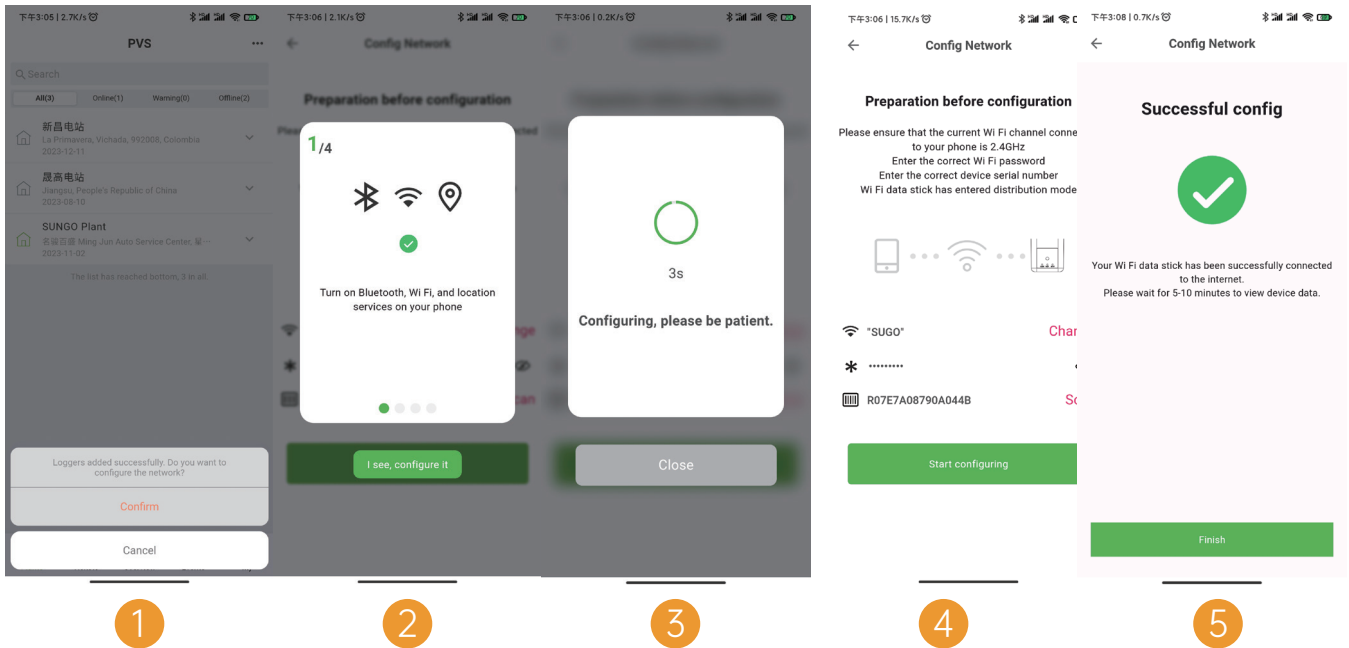

Just follow the instructed process to show the successful distribution of the network.

Step 6. Optimizer Status View

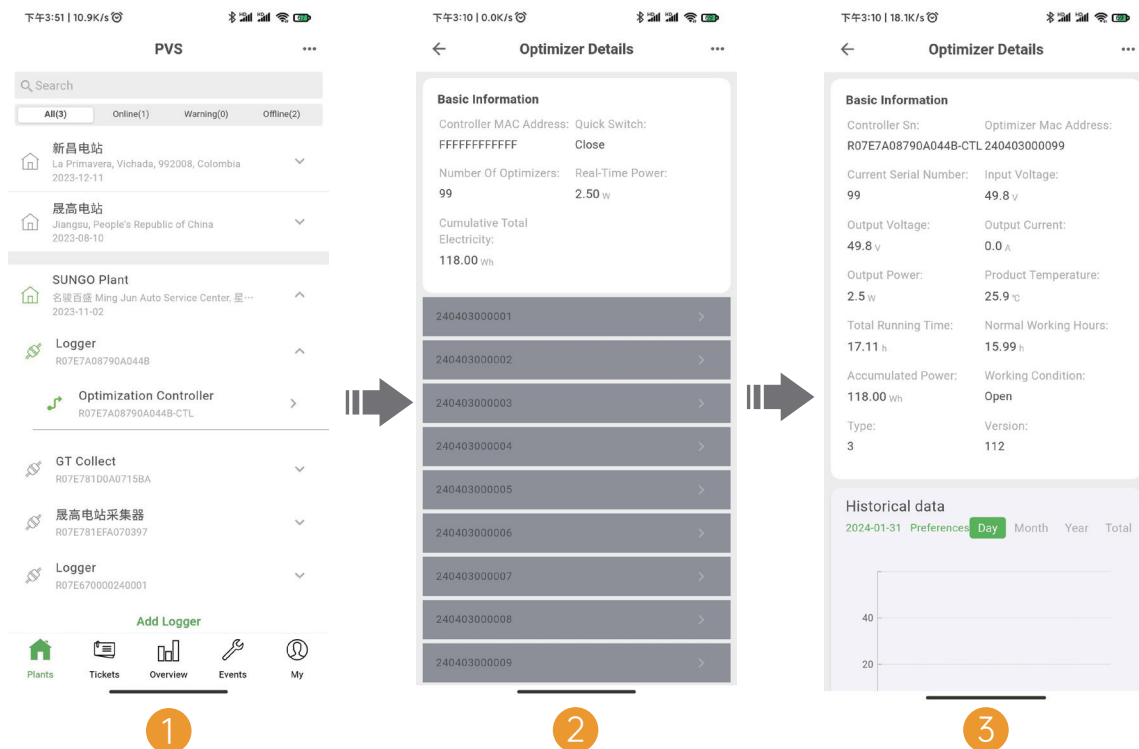

After successful grid distribution, click on the arrow to the right of the power station project until the optimizer controller appears, then click on the optimizer controller, then click on the Optimizer Code to view the optimizer details.

Step 7. Check the status of the power station

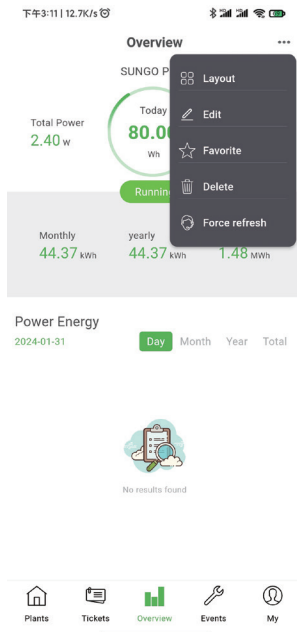

Click on APP OVERVIEW, then open the drop-down menu in the upper right corner of the page. Click on the layout to see the status.

After clicking Layout, the status of the power plant is displayed in several states as shown below.

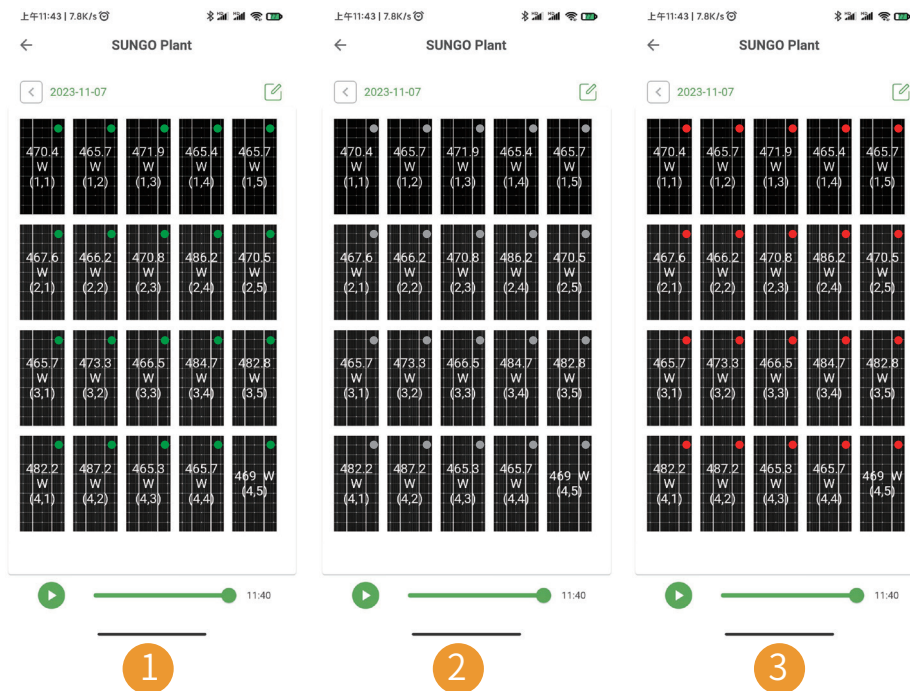

| State of affairs | Clarification |
|---|--|
| Figure 1 - Green circle in the upper right corner | Optimizer is running fine |
| Figure 2 - Gray circle in the upper right corner | Optimizer is offline, please check that the SN and location information is correct and then search the device again! |
| Figure 3 - Red circle in the upper right corner | Optimizer failure, need to replace optimizer |

Global Headquarters

SUNGO Energy Technology (Jiangsu) Co., Ltd.
Add: Unit 01, Floor 1, NO.179 Suhong West Road, Suzhou Industrial
Park, Suzhou City, Jiangsu Province, China

Europe Headquarters

SUNGO Energy Technology B.V.
Add: Hoofdweg-Noord 9T, 2913LB Nieuwerkerk aan den IJssel, The Netherlands

Optimizer&Energy Storage Production base

KONKA&SUNGO Smart Energy (Zhejiang) Co., Ltd.
Add: Building 3#, Small and Micro Industrial Park, No. 69 Xingmei Avenue, Chengtan
Street, Xinchang County, Shaoxing City, Zhejiang Province, China

Sungo Energy UK

Add: 60 Windsor Avenue, London SW19 2RR, United Kingdom

Sungo Energy Japan

SungoEnergy株式会社
Add: 4-16-5-206 Sekimae, Musashino City, Tokyo

Sungo Energy USA

SUNGO ENERGY TECHNOLOGY INC.
Add: 5900 Balcones Drive, STE 100 Austin TX 78731

Web: www.sungoess.com

E-mail: sales@sungoess.com

Global Headquarters Tel: +86 (0)512 6512 2036

Europe Headquarters Tel: +31 (0)10 307 21 68

SUNGO Energy UK Tel: +44 (0) 330 122 6559

After-sales e-mail: after-sales@sungoess.com



Linkedin



Facebook



Tiktok



Youtube

© Sungo reserves all rights. All other trademarks mentioned in this document are trademarks of their respective owners.
The information in this document is for reference only and does not constitute any offer or commitment.
Sungo may modify the above information without prior notice.